

Public Information	
Document Number: P-REP-07701-00001	
Sheet Number: N/A	Revision: R000
Title: ENVIRONMENTAL RISK ASSESSMENT REPORT FOR PICKERING NUCLEAR	

**Environmental Risk Assessment Report
for Pickering Nuclear**

P-REP-07701-00001 R000

April 2017

Public Information

Accepted by: Raphael McCalla
Director – Nuclear Environment
Environment



**Environmental Risk Assessment Report for Pickering Nuclear
P-REP-07701-00001 R0**



Report prepared for:

ONTARIO POWER GENERATION
889 Brock Road
Pickering, Ontario
L1W 3J2

Report prepared by:

ECOMETRIX INCORPORATED/ Golder Associates Ltd
6800 Campobello Road
Mississauga, Ontario
L5N 2L8

Ref. 15-2170
April 2017

LIST OF ACRONYMS AND SYMBOLS

ACRONYMS

AAQC	Ambient Air Quality Criteria
ALARA	As Low As Reasonably Achievable
ATSDR	Agency for Toxic Substances and Disease Registry
BAF	Bioaccumulation Factor
BCF	Bioconcentration Factor
BC MOE	British Columbia Ministry of the Environment
BOD	Biochemical Oxygen Demand
BTEX	Benzene, Toluene, Ethylbenzene, and Xylenes
BV	Benchmark Value
CANDU	CANada Deuterium Uranium
CCME	Canadian Council of Ministers of the Environment
CCW	Condenser Cooling Water
CEAA	Canadian Environmental Assessment Act
CNSC	Canadian Nuclear Safety Commission
CofA	Certificate of Approval
COD	Chemical Oxygen Demand
COG	CANDU Owners Group
COPC	Contaminant Of Potential Concern
COSEWIC	Committee on the Status of Endangered Wildlife in Canada
CSA	Canadian Standards Association
DC	Dose Coefficient
DN	Darlington Nuclear
DRL	Derived Release Limit
DRPD	Durham Region Planning Department
DSC	Dry Storage Container
DWSP	Drinking Water Surveillance Program
EA	Environmental Assessment
EC/HC	Environment Canada/Health Canada
ECA	Environmental Compliance Approval
EcoRA	Ecological Risk Assessment
ELC	Ecological Land Classification
EMP	Environmental Monitoring Program
ERA	Environmental Risk Assessment
ESA	Environmental Site Assessment
ESDM	Emissions Summary and Dispersion Modelling
ESL	Effects Screening Limits
EV	Exposure Values
FDS	Fish Diversion System

FEQG	Federal Environmental Quality Guideline
FUMP	Follow-Up and Monitoring Program
GLFC	Great Lakes Fishery Commission
HHRA	Human Health Risk Assessment
HQ	Hazard Quotient
HTS	Heat Transport System
IARC	International Agency for Research on Cancer
ICRP	International Commission on Radiological Protection
ILCR	Incremental Lifetime Cancer Risk
ILW	Intermediate Level Waste
JSL	Jurisdictional Screening Levels
LCV	Lowest Chronic Value
LLW	Low Level Waste
LOAEL	Lowest Observed Adverse Effect Level
LOEC	Lowest Observed Effect Concentration
LSA	Local Study Area
MDL	Method Detection Limit
MISA	Municipal Industrial Strategy for Abatement
MOE	Ontario Ministry of Environment
MOECC	Ontario Ministry of Environment and Climate Change
MTE	Maximum Temperature for Embryos
MWAT	Maximum Weekly Average Water Temperatures
NEW	Nuclear Energy Worker
NOEC	No Observed Effect Concentration
NOAEL	No Observed Adverse Effect Level
NSCA	Nuclear Safety and Control Act
NWTP	New Water Treatment Plant
OMNR	Ontario Ministry of Natural Resources
OPG	Ontario Power Generation
PAH	Polycyclic Aromatic Hydrocarbon
PHC	Petroleum Hydrocarbons
PN	Pickering Nuclear
POI	Point of Impingement
PWMF	Pickering Waste Management Facility
PWQO	Provincial Water Quality Objective
QA	Quality Assurance
QSAR	Quantitative Structure-Activity Relationship
RBE	Relative Biological Effectiveness
RLWMS	Radioactive Liquid Waste Management System
RSA	Regional Study Area
SARO	Species at Risk in Ontario
SCV	Secondary Chronic Value

SSA	Site Study Area
STDM	Short-Term Daily Maximum
TCEQ	Texas Commission on Environmental Quality
TF	Transfer Factor
TLV	Threshold Limit Value
TRC	Total Residual Chlorine
TRCA	Toronto and Region Conservation Authority
TRV	Toxicity Reference Value
TSD	Technical Support Document
TSS	Total Suspended Solids
UF	Uncertainty Factor
UNSCEAR	United Nations Scientific Committee on the Effects of Atomic Radiation
UPP	Upgrading Plant Pickering
US EPA	United States Environmental Protection Agency
VEC	Valued Ecosystem Component
WHO	World Health Organization
WSP	Water Supply Plant
WWMF	Western Waste Management Facility

SYMBOLS

Human Non-radiological Parameters

C_{air}	=	air concentration ($\mu\text{g}/\text{m}^3$).
C	=	concentration of contaminant in drinking water (mg/L)
IR	=	receptor intake rate (L/d)
RAF_{GIT}	=	absorption factor from the gastrointestinal tract (unitless)
D_2	=	days per week exposed $\cdot (7 \text{ days})^{-1}$ (d/d)
D_3	=	weeks per year exposed $\cdot (52 \text{ weeks})^{-1}$ (wk/wk)
D_4	=	total years exposed to site (years) (for carcinogens only)
BW	=	body weight (kg)
C_{foodi}	=	concentration of contaminant in food i (mg/kg)
IR_{foodi}	=	receptor ingestion rate for food i (kg/d)
RAF_{GITi}	=	relative absorption factor from the gastrointestinal tract for contaminant i (unitless)
D_i	=	days per year during which consumption of food i will occur (d/a)
LE	=	life expectancy (years) (for carcinogens only)
P_{01}	=	transfer parameter from source emission to air

Environmental Partitioning Parameters

$C_{s(fw)}$	=	concentration in sediment (Bq/kg fw)
C_w	=	concentration in water (Bq/L)
ρ_w	=	density of water (1 kg/L)

θ	=	sediment porosity (unitless)
K_d	=	distribution coefficient (L/kg solid)
ρ_s	=	density of solids (kg/L)
$C_{s(dw)}$	=	concentration in sediment (Bq/kg dw)
f_{dw}	=	dry weight fraction of sediment (unitless).

Ecological Radiological Dose Parameters

D_{int}	=	internal radiation dose ($\mu\text{Gy/d}$)
D_{ext}	=	external radiation dose ($\mu\text{Gy/d}$)
D_{NG}	=	noble gas dose (Gy/a)
DC_a	=	effective dose coefficient for a semi-infinite cloud for a mixture of noble gases (Sv/a)/(Bq·MeV/m ³)
DC_{int}	=	internal dose coefficient (($\mu\text{Gy/d}$)/(Bq/kg))
DC_{ext}	=	external dose coefficient (($\mu\text{Gy/d}$)/(Bq/kg))
$DC_{ext,w}$	=	external dose coefficient (in water)
$DC_{ext,s}$	=	external dose coefficient (in soil) (($\mu\text{Gy/d}$)/(Bq/kg))
$DC_{ext,ss}$	=	external dose coefficient (on soil surface) ($\mu\text{Gy/d}$)/(Bq/kg))
C_{airNG}	=	noble gas concentration in air (Bq·MeV/m ³)
C_m	=	media concentration (Bq/L or Bq/kg)
C_f	=	average concentration in food (Bq/kg fw)
C_w	=	water concentration (Bq/L)
C_s	=	soil/sediment concentration (Bq/kg fw)
C_t	=	whole body tissue concentration (Bq/kg fw)
C_x	=	concentration in the ingested item x (Bq/kg fw)
OF_w	=	occupancy factor in water
OF_{ws}	=	occupancy factor at water surface
OF_s	=	occupancy factor in soil/sediment
OF_{ss}	=	occupancy factor at soil/sediment surface
BAF	=	bioaccumulation factor (L/kg or kg/kg)
BMF	=	biomagnification factor (unitless)
I_x	=	ingestion rate of item x (kg fw/d)
TF	=	ingestion transfer factor (d/kg)
DW_a	=	dry/fresh weight ratio for animal products (kg-dw/kg-fw)
$1-DW_a$	=	water content of the animal (L water /kg-fw)
$1-DW_p$	=	water content of the plant/food (L water /kg-fw plant)
BAF_{a_HTO}	=	aquatic animal BAFs for tritium (L/kg-fw)
BAF_{p_HTO}	=	plant BAF for tritium (L/kg-fw)
P_{air_plant}	=	transfer from air to plant (m ³ /kg-fw)
P_{air_spw}	=	transfer from air to soil pore water (m ³ /L)
θ	=	volumetric moisture content of soil (m ³ water/m ³ soil)
ρ_b	=	bulk density of the soil (kg/m ³)
k_{af}	=	fraction of food from contaminated sources
k_{aw}	=	fraction of water from contaminated sources (assumed to be 1)

f_{OBT}	=	fraction of total tritium in the animal product in the form of OBT as a result of HTO ingestion
f_{w_w}	=	fraction of the animal water intake derived from direct ingestion of water
f_{w_pw}	=	fraction of the animal water intake derived from water in the plant feed
f_{w_dw}	=	fraction of the animal water intake that results from the metabolic decomposition of the organic matter in the feed
$P_{HTOwater_animal}$	=	transfer of HTO to animals through water ingestion (L/kg-fw)
$P_{HTOfood_animal}$	=	transfer of HTO to animals through food ingestion
$P_{HTOsoil_plant}$	=	transfer of HTO from soil to plant
S_a	=	stable carbon content in the aquatic animal/invertebrate/plant (gC/kg-fw)
S_w	=	mass of stable carbon in the dissolved inorganic phase in water (gC/L)
S_a	=	stable carbon content in the animal (gC/kg-fw)
S_p	=	stable carbon content in the food (gC/kg-fw)
$BAFa_{C14}$	=	C-14 BAF for aquatic animals, invertebrates, and plants (L/kg-fw)
$P_{C14food_animal}$	=	transfer of C-14 from food to animals

Ecological Non-Radiological Parameters

C_x	=	concentration in the ingested item (x) (mg/kg)
D_{ing}	=	dose from ingestion pathway (mg/kg body weight/d)
I_x	=	ingestion rate of item x (kg/d)
W	=	body weight of consumer (kg fw)
ΔT	=	change in temperature ($^{\circ}C$)

Executive Summary

The following document is the Environmental Risk Assessment (ERA) for Pickering Nuclear (PN), which meets the requirements of the Canadian Standards Association (CSA) N288.6-12 standard “Environmental risk assessments at Class I nuclear facilities and uranium mines and mills” (CSA, 2012). The standard requires a human health risk assessment (HHRA) and an ecological risk assessment (EcoRA), for both radiological and non-radiological contaminants and physical stressors. The results of the ERA inform the environmental monitoring programs (EMP) and effluent monitoring programs, as per CSA N288.4-10 “Environmental monitoring programs at Class I nuclear facilities and uranium mines and mills” (CSA, 2010) and CSA N288.5-11 “Effluent monitoring programs at Class I nuclear facilities and uranium mines and mills” (CSA, 2011), respectively. These programs can also inform the ERA by providing information on effluent concentrations and loadings, and by providing environmental data to assist in model calibration and validation. This ERA focuses on the 2011 to 2015 period.

The PN site is located in the City of Pickering on the north shore of Lake Ontario at Moore Point, about 32 km east of downtown Toronto and 21 km west of Oshawa. The PN site is comprised of the PN Generating Station, with six operating CANada Deuterium Uranium (CANDU) pressurized heavy water generating stations, and two units in safe storage.

In 2014, an updated integrated EcoRA and HHRA was prepared consistent with CSA N288.6-12 guidance, using monitoring data from the five-year period of 2007 to 2011. The ERA identified a number of areas where supplementary monitoring studies were recommended including collecting updated soil data on the PN site, collecting lake water samples along the PN discharge channels for low-level hydrazine detection, and collecting sediment and water samples from the northern section of the Frenchman’s Bay wetland.

Additional data were collected and are used in this ERA, including routine environmental and effluent monitoring data from 2011 to 2015. The additional data were collected based on the recommendations of the 2014 ERA, the age of site environmental data and recent site alteration due to the development of Building #3 for the Pickering Waste Management Facility. The baseline environmental sampling program included collection of:

- Lake surface water data;
- Sediment and surface water data from Frenchman’s Bay;
- Stormwater data;
- Soil data; and
- Noise data.

The overall goals of this ERA were:

- To establish an updated environmental baseline condition for the PN site.

- To support assessment of the future shutdown and safe storage of PN.
- To update the ERA in general accordance with the CSA N288.6-12 Standard.
- To provide focus for the environmental monitoring program on relevant contaminants of potential concern, media, and ecological and human receptors.

The specific objectives of this ERA, consistent with CSA N288.6-12, were:

- To evaluate the risk to relevant human and ecological receptors resulting from exposure to contaminants and physical stressors related to the PN site and its activities.
- To recommend potential further monitoring or assessment as needed based on the results of the ERA.

Human Health Risk Assessment (HHRA)

Predicted exposures to sources from PN were evaluated on the basis of toxicological effects from non-carcinogenic contaminants of potential concern, potential cancer risk from carcinogens, and potential radiation exposure from radionuclides.

Human Receptors

Human receptors evaluated included off-site members of the public, specifically those critical groups used for dose calculations in the annual Ontario Power Generation (OPG) EMP reports within approximately 20 km of the PN site, including:

- C2 Correctional Institution;
- Local Residents;
- Local Farms;
- Local Dairy Farms;
- Sport Fishers; and
- Off-site Industrial/Commercial Workers.

These six critical groups were used for the exposure assessment for both radiological and non-radiological contaminants of potential concern.

On-site receptors were not addressed in the HHRA, since human exposures on the site are kept within safe levels through OPG's Health and Safety Management System Program and Radiation Protection Program.

Screening of Contaminants of Potential Concern for Human Health

The facilities at the PN site emit radiological and non-radiological contaminants to air, water, soil, and groundwater in the normal course of operations. Measurements and modeled concentrations of contaminants of potential concern were screened against

available screening benchmarks that are protective of human health to determine if any contaminants of potential concern required further study in the context of HHRA. Table ES-1 provides a summary of the contaminants of potential concern carried forward for further quantitative assessment in the HHRA.

Selected radiological stressors are considered of public interest and therefore, were carried forward quantitatively in the HHRA and did not undergo a formal screening assessment. The radionuclides selected for use in Derived Release Limit (DRL) calculations were considered appropriate for assessment in the HHRA, as discussed in Section 3.1.2.5.

Human exposure to contaminants of potential concern from on-site groundwater was not evaluated since there are no complete exposure pathways for human receptors to site groundwater. Non-radiological contaminants of potential concern were not assessed in soil, since there are no complete human exposure pathways for site soil, and the PN site is not a source of dust for off-site soil.

Physical stressors such as noise are relevant to human receptors. There are periods where noise levels at Points of Reception in the vicinity of PN were above the Ontario Ministry of the Environment and Climate Change Environmental Noise Guideline, Stationary and Transportation Sources – Approval and Planning NPC 300 Class 1 and Class 2 sound level limits; therefore, noise was carried forward as a physical stressor in the HHRA.

Table ES-1: Summary of Contaminants of Potential Concern Selected for Human Health Risk Assessment

Category	Radiological Contaminant of Potential Concern	Non-Radiological Contaminant of Potential Concern
Air	Tritium, noble gases, carbon-14, I (mixed fission products), mixed beta/gamma particulates (represented by cobalt-60)	Hydrazine
Surface water	Tritium, carbon-14, gross beta/gamma (represented by cesium-137)	Hydrazine morpholine
Groundwater	None	None
Stormwater	None	None
Soil	Cesium-134, cesium-137, cobalt-60	None
Noise	Yes	

Results of HHRA

Non-radiological HHRA

The complete exposure pathways that were assessed in the non-radiological HHRA included:

- Inhalation (hydrazine) for all six human receptor groups;
- Water ingestion (hydrazine and morpholine) for the Urban Resident, Correctional Institution, and Industrial/Commercial Worker; and
- Fish ingestion (hydrazine and morpholine) for the Sport Fisher.

Potential risks to human receptors were characterized quantitatively in terms of Hazard Quotients for non-carcinogens (morpholine) and Incremental Lifetime Cancer Risks for potential carcinogens (hydrazine). The acceptable risk levels are less than 0.2 for non-cancer risk (Hazard Quotient) and less than a cancer risk of 10^{-6} (Incremental Lifetime Cancer Risk). The results of the qualitative HHRA are as follows.

- No increased risk to human receptors is expected resulting from exposure to morpholine.
- No risks to the urban resident, correctional institution resident and industrial/commercial worker are expected due to exposure to modelled hydrazine in drinking water at the Ajax Water Supply Plant.
- No risks to the sport fisher are expected from fish ingestion due to mean modelled hydrazine in fish tissue. Since fish are mobile, exposure to the mean hydrazine concentration is more realistic than exposure to the maximum. The maximum would exceed the acceptable cancer risk level; however, the maximum risk estimated is conservative.
- The estimated risks to all human receptors from inhalation of hydrazine are below the acceptable cancer risk level.

Radiological HHRA

For exposure of human receptors to radiological contaminants of potential concern, the relevant exposure pathways and human receptors (critical groups) were those presented in the annual OPG EMP reports. Radiological dose calculations followed the methodology outlined in CSA N288.1-08. The annual dose to the critical group (the urban resident adult) during this five year period ranged from 0.9 to 1.2 microSieverts, approximately 0.1% of the regulatory public dose limit of 1 mSv/a and approximately 0.1% of the dose due to Canadian background radiation. Since the critical groups receive the highest dose from PN, the demonstration that they are protected implies that other receptor groups near PN are also protected.

The Sport Fisher may receive a maximum dose up to 0.14 microSieverts per annum from exposure to the PWMF (Phase I and Phase II) at full capacity; however, this is still a small fraction of the regulatory public dose limit, and their total dose is still below the reported PN public dose.

Noise

The Acoustic Assessment Report (OPG, 2011c) prepared for PN and the Environmental Compliance Approval for Air and Noise, issued by the Ontario Ministry of Environment and Climate Change demonstrate that PN operates in compliance within applicable regulatory noise limits and therefore, adverse effects are not expected (OPG, 2015f).

Through a review of noise monitoring data in combination with site observations, it is not likely that noise from PN activities is having a direct adverse effect on human receptors near the PN site.

Ecological Risk Assessment (EcoRA)

Valued Ecosystem Components

The assessment for the EcoRA focused on the nearshore Lake Ontario (generally in the area surrounding the PN outfalls), the PN site, and Frenchman's Bay. Valued ecosystem components were selected for dose and risk analysis because they are known to exist on-site, and/or are representative of major taxonomic/ecological groups, major pathways of exposure, or have a special importance or value. The model used for assessment of dose and risk is either specific to the selected valued ecosystem component species, or is a more generic biota assessment model that is appropriate to a number of valued ecosystem components with similar exposure characteristics. Table ES-2 shows the selected valued ecosystem components and the assessment models used in estimating their contaminant of potential concern exposure, dose and risk. Protection of the valued ecosystem components implies that other species in the same valued ecosystem component category are also protected.

Table ES-2: Summary of Valued Ecosystem Components and their Assessment Models used in the EcoRA

Valued Ecosystem Component Category	Assessment Model	Valued Ecosystem Component
Fish	Bottom Feeding Fish	Brown Bullhead
		Round Whitefish
		White Sucker
		American Eel
	Pelagic Fish	Alewife
		Smallmouth Bass
		Lake Trout
		Walleye
	Northern Pike	
Amphibians and Reptiles	Bottom Feeding Fish	Northern Leopard Frog

Valued Ecosystem Component Category	Assessment Model	Valued Ecosystem Component
		Midland Painted Turtle
Aquatic Plants	Aquatic Plant	Narrow-leaved Cattail
Aquatic Invertebrates	Benthic Invertebrate	Benthic Invertebrates
Riparian Birds	Trumpeter Swan	Trumpeter Swan
	Ring-billed Gull	Ring-billed Gull
	Common Tern	Common Tern
	Bufflehead	Bufflehead
Riparian Mammals	Muskrat	Muskrat
Terrestrial Plants	Terrestrial Plants	Chokecherry
		New England Aster
		Eastern Hemlock
		Red Ash
		Sandbar Willow
		Pine
Terrestrial Invertebrates	Soil Invertebrate	Earthworms
Terrestrial Birds	Red-winged Blackbird	Red-winged Blackbird
	Red-tailed Hawk	Red-tailed Hawk
Terrestrial Mammals	Red Fox	Red Fox
	Meadow Vole	Meadow Vole

A number of threatened and endangered species have been identified within the PN Terrestrial Site Study Area during the 2011 to 2015 time period, including Barn Swallow, Least Bittern, Butternut, and American Eel. Each of these species was assigned a representative species already selected for the EcoRA.

Assessment endpoints are attributes of the receptors to be protected in environmental programs (Suter *et al.*, 1993). The purpose of an ERA is to evaluate whether these environmental protection goals are being achieved or are likely to be achieved. The assessment endpoint for all receptors in this ecological risk assessment is population abundance. The assessment endpoint for the identified species at risk is the individual, since effects on even a few individuals of species at risk would not be acceptable.

Screening of Contaminants of Potential Concern for Ecological Assessment

The same monitoring data sources previously screened for the HHRA were screened for the EcoRA using the more conservative of available federal and provincial guidelines and objectives as screening criteria. If there was no such guideline or objective, screening

criteria were obtained from the literature, and/or derived using federally and/or provincially accepted methods. For contaminants of potential concern where these criteria were not available, upper estimates of background concentrations or conservative toxicity benchmarks (e.g., no effects levels) were used as screening criteria. Maximum measured concentrations of parameters in surface water, sediment, soil, and air were compared to the selected screening criteria to determine the list of contaminants of potential concern. Contaminants were also retained if no screening criteria were available or if they are considered of public interest (e.g., radionuclides). Table ES-3 provides a summary of the contaminants of potential concern carried forward for further quantitative assessment in the EcoRA.

Surface water and sediment data were collected in the summer of 2015 from Frenchman's Bay and a large number of contaminants of potential concern exceeded screening levels. This is not uncharacteristic for an area such as Frenchman's Bay that is highly influenced by urban runoff. An assessment was performed in Appendix E to determine the proportion of the overall risk to aquatic receptors at Frenchman's Bay that can be attributed to PN.

Certain pathways were considered minor or incomplete and therefore, were not evaluated. For the majority of contaminants of potential concern the air pathway is a minor exposure pathway relative to soil and food ingestion exposure for ecological receptors. Ecological exposure to contaminants of potential concern from on-site groundwater was not evaluated since there are no complete exposure pathways for ecological receptors to site groundwater.

Thermal stressors and entrainment and impingement were carried forward for assessment in the EcoRA since they are widely recognized as being of primary concern in nuclear power plants, as recommended by CSA N288.6-12. Other physical stressors such as noise, wildlife strikes with vehicles, bird/bat strikes on buildings, shoreline alteration and lake filling, terrestrial landscape alteration and land use, and sedimentation screened out and were not carried forward for further assessment in the EcoRA.

Table ES-3: Summary of Contaminants of Potential Concern and other Physical Stressors Selected for the Ecological Risk Assessment

Category	Radiological Contaminant of Potential Concern	Non-Radiological Contaminant of Potential Concern
Air	Noble gases (represented by argon-41) (PN site)	None
Surface water	Tritium, carbon-14, gross beta-gamma (represented by cobalt-60), cesium-134, cesium-137 (Lake and Frenchman's Bay)	Hydrazine, total residual chlorine, morpholine, copper (Lake Ontario) sulphate (East Landfill only)

Category	Radiological Contaminant of Potential Concern	Non-Radiological Contaminant of Potential Concern
		total aluminum, copper, iron, and sodium (Frenchman's Bay)
Groundwater	None	None
Stormwater	None	None
Sediment	Carbon-14, cesium-134, cesium-137, cobalt-60 (Frenchman's Bay)	Aluminum, bismuth, boron, cadmium, calcium, chromium, copper, lead, manganese, nickel, phosphorous, thorium, tin, zinc, total organic carbon (Frenchman's Bay)
Soil	Tritium, carbon-14, cesium-134, cesium-137, cobalt-60 (PN site)	Cyanide, arsenic, copper, lead, zinc, and petroleum hydrocarbon F4 (PN site)
Physical Stressors (e.g., noise, bird strikes/wildlife collisions)	None	
Physical Stressors (other)	Impingement/entrainment	
	Thermal plume	

Results of the EcoRA

Non-radiological EcoRA

The potential for ecological effects was assessed by comparing exposure levels to toxicological benchmarks, and characterized quantitatively in terms of Hazard Quotients. A Hazard Quotient greater than 1 indicates a need to more closely assess the risk to the concerned valued ecosystem component.

Outfall

Maximum and mean measured concentrations of hydrazine, morpholine, and total residual chlorine in the outfall did not exceed their respective benchmarks for the ecological receptors evaluated.

Measured maximum copper concentrations in water near the PN outfall are above the fish and benthic invertebrate benchmarks; therefore the risk (Hazard Quotient) was above the acceptable risk level of 1. Based on mean copper concentrations in water near the PN outfall, the risk for fish and benthic invertebrates was acceptable. Since fish are mobile, exposure to the mean concentration is more likely. Estimated maximum copper concentrations in sediment near the PN outfall also slightly exceeded the benthic

invertebrate benchmark for copper; however, estimated mean copper concentrations in sediment were below the benchmark. Although a few benthic invertebrates may be exposed to these maximum measured water concentrations and estimated sediment concentrations, the community as a whole is not expected to be affected. Additionally, there is uncertainty surrounding this risk as the sediment in Lake Ontario near PN is transient, and the invertebrate community is mainly epifaunal.

The American Eel is identified as a species at risk; therefore the assessment endpoint is the health of the individual. As discussed above the fish benchmark was exceeded in the outfall for maximum copper concentration in water. However, based on mean water concentrations, the fish benchmark was not exceeded for copper. Since fish are mobile and occupy a larger area than the outfall, the Hazard Quotients for mean water concentrations are more representative than maximum concentrations. As such, the American Eel is likely not at risk from any contaminants of potential concern arising from PN operations.

Overall, the risk to fish at the outfall is low, and fish are not expected to experience any adverse effects due to non-radiological releases from PN operations.

Frenchman's Bay

Maximum and mean measured concentrations of hydrazine, morpholine, total residual chlorine, and sodium at Frenchman's Bay did not exceed their respective benchmarks for the ecological receptors evaluated at Frenchman's Bay.

The maximum measured copper concentration in water at Frenchman's Bay is marginally above the aquatic plant benchmark; however, the mean measured copper concentration in water at Frenchman's Bay is below the aquatic plant benchmark. The maximum and mean measured copper concentrations in sediment were above the benthic invertebrate benchmark. Although a few benthic invertebrates may be exposed to these maximum measured concentrations, the community as a whole is not expected to be affected. Additionally, the contribution from PN operations to the maximum and mean copper concentrations in water (and then partitioning to the sediment) at Frenchman's Bay is low ranging from 9% to 11% (see Appendix E, Table E.9).

The maximum measured iron concentration in water at Frenchman's Bay was above the benthic invertebrate benchmark; however, the mean measured iron concentration in water at Frenchman's Bay was below the benthic invertebrate benchmark. Additionally, the maximum and mean measured iron concentrations in sediment at Frenchman's Bay did not exceed the sediment benchmarks for benthic invertebrates.

The results of the EcoRA to the riparian mammals and birds at Frenchman's Bay are summarized below:

- The risk (Hazard Quotient) to the muskrat from aluminum (maximum and mean) was above the acceptable risk level of 1.
- The risk (Hazard Quotient) to the Trumpeter Swan from iron (maximum and mean) was above the acceptable risk level of 1.
- The risk (Hazard Quotient) to the Bufflehead from aluminum and iron (maximum and mean) was above the acceptable risk level of 1.
- The risk (Hazard Quotient) to the Common Tern from iron (maximum) was above the acceptable risk level of 1.
- The (Hazard Quotient) risk to the Ring-billed Gull from iron (maximum and mean) was above the acceptable risk level of 1.

Many of these receptors would not reside at Frenchman's Bay exclusively; therefore the results of the EcoRA are conservative. Additionally, as discussed in Appendix E, exceedances of toxicity benchmarks are not uncharacteristic for an area such as Frenchman's Bay that is highly influenced by urban runoff. PN operations contribute a small proportion of the overall risk to aquatic receptors at Frenchman's Bay. The percent contribution from PN ranges from 0.3% to 22% over all contaminants of potential concern (see Appendix E).

Least Bittern was identified as a species at risk observed on the PN Terrestrial Site Study Area; therefore the assessment endpoint is the health of the individual. The representative species in this ERA is the Common Tern. As discussed above, the Hazard Quotient for the Common Tern exceeded the acceptable risk level of 1 for maximum concentrations of iron in Frenchman's Bay. However, based on mean concentrations the risk for the Common Tern did not exceed the acceptable risk level of 1. Since the Common Tern (and Least Bittern) is mobile, mean exposure is more representative than maximum exposure. As such, the Least Bittern (represented by the Common Tern) is likely not at risk from iron exposure in Frenchman's Bay.

Pickering Nuclear Site

In general, soils on site that exceed benchmark concentrations are localized, suggesting the influence of past industrial operations rather than deposition from atmospheric sources. As such, accumulation of contaminants of potential concern in soil over time is not expected. The soil sampling program focused on areas of previously identified contamination. Although, soil sampling only occurred in areas identified as potential habitat, many of these areas on the PN site are not likely to be frequented by the selected valued ecosystem components since they are near PN operations and not in highly vegetated areas.

The results of the EcoRA to the terrestrial valued ecosystem components at the PN site are summarized below:

- The risk (Hazard Quotient) to the earthworm from measured soil concentrations for copper (maximum), zinc (maximum and mean), and petroleum hydrocarbon F4 (maximum) was above the acceptable risk level of 1.
- The risk (Hazard Quotient) to the terrestrial plant from measured soil concentrations for arsenic (maximum), copper (maximum), zinc (maximum and mean), and petroleum hydrocarbon F4 (maximum) was above the acceptable risk level of 1.
- The (Hazard Quotient) risk to the Meadow Vole from copper (maximum) was above the acceptable risk level of 1.
- The risk (Hazard Quotient) to the Red-winged Blackbird from copper (maximum), lead (maximum), and zinc (maximum) was above the acceptable risk level of 1.
- The (Hazard Quotient) risk to the Red-tailed Hawk from lead (maximum), and zinc (maximum) was above the acceptable risk level of 1.

Based on the results above, acceptable risk levels were not exceeded for mammals or birds exposed to average concentrations in soil; therefore, adverse effects are not expected. These receptors, with the exception of the Meadow Vole, are highly mobile and are unlikely to be exposed to the maximum concentrations for the entire year. Although localized effects to individual birds/mammals may occur, the populations on the site as a whole are not expected to be affected.

Based on the results above, acceptable risk levels were exceeded for earthworms and terrestrial plants. Although localized effects to individual earthworms/plants may occur, the earthworm community and terrestrial plant population on the site as a whole are not expected to be affected.

Barn Swallow is identified as species at risk; therefore the assessment endpoint is the health of the individual. The representative species in this ERA is the Red-winged Blackbird. As discussed above, the Red-winged Blackbird exceeded the acceptable risk level of 1 for maximum concentrations of copper, lead, and zinc in soil. However, based on mean concentrations Hazard Quotients for copper, lead, and zinc did not exceed the acceptable risk level of 1. Since birds are mobile, mean exposure is more representative than maximum exposure. As such, the Barn Swallow is likely not at risk from PN operations.

Butternut trees are identified as a species at risk; therefore, the assessment endpoint is the health of the individual. The representative species in this ERA is Red Ash (terrestrial plant). While individual trees may be potentially exposed to concentrations above the soil benchmark, there are no trees in these areas of maximum soil concentrations on the PN site, therefore, Butternut is not at risk in the localized areas of benchmark exceedance.

East Landfill

The maximum sulphate concentration observed in the East Landfill is well below the lethal concentration for 20% of test organisms for trout of 857 mg/L at a hardness of 250 mg/L (BC MOE, 2013) as well as the lethal concentration for 25% of test organisms for *C. dubia* of 425 mg/L at a hardness of 320 mg/L (Elphick et al., 2011). The maximum sulphate in Ditch 6 (the final surface water discharge point from the East Landfill to Lake Ontario located southeast of the landfill) is below these effect levels as well as below the British Columbia Ministry of Environment sulphate guideline at the maximum hardness. Based on these observations, sulphate levels in Ditch 6 are not likely of concern.

Radiological EcoRA

Radiation dose benchmarks of 400 microGray per hour (9.6 milliGray per day) and 100 microGray per hour (2.4 milliGray per day) (UNSCEAR, 2008) were selected for the assessment of effects on aquatic biota and terrestrial biota, respectively, as recommended in the CSA N288.6-12 standard (CSA 2012).

Outfall

There were no exceedances of the radiation dose benchmarks for the aquatic biota at the outfall location including fish, benthic invertebrates, and Ring-billed Gull.

Frenchman's Bay

There were no exceedances of the radiation dose benchmarks for any aquatic receptors at Frenchman's Bay.

Pickering Nuclear Site

There were no exceedances of the radiation dose benchmark for terrestrial biota on the PN site including earthworms, terrestrial plants, Meadow Vole, Red-winged Blackbird, Red Fox, and Red-tailed Hawk.

Pickering Waste Management Facility

The maximum dose rate to any ecological VEC residing in close proximity to the PVMF could be up to 0.012 milliGray per day, lower than the 2.4 milliGray per day radiation benchmark for terrestrial biota.

Thermal Effects

Cooper (2013) evaluated lake temperatures in the vicinity of the PN U5-8 discharge. Temperature results at locations in the thermal plume and in reference areas (Thickson

Point and Bonnie Brae Point) were compared to thermal criteria (maximum weekly average water temperature and short-term daily maximum criteria) relevant to spawning and embryo-larval periods, and juvenile and adult stages to determine Hazard Quotient values. A Hazard Quotient above 1 is indicative of potential adverse effects from the thermal plume.

For fish spawning and embryo-larval development, Cooper (2013) found that the highest Hazard Quotients were marginally above 1 in the plume, but usually very similar in the reference.

OPG (2017) evaluated the lake water temperature from the thermal plume at PN and reference sites from 2009-2010, 2010-2011 and 2011-2012 using a revised impact assessment model to predict hatch date and survival of Round Whitefish embryos. The estimated survival loss at the plume stations compared to the reference stations, were all below the survival loss of 10%, the threshold for no-effect level for Round Whitefish embryo survival. The average water temperature during the spawning and egg incubation period for all plume stations and each individual station in 2009-2010, 2010-2011 and 2011-2012 were below the threshold effect level of 6°C in each year (OPG, 2017). Therefore, the thermal plume from PN is not having an adverse effect on Round Whitefish embryo survival.

For fish growth (juvenile and adult), Cooper (2013) found that the highest Hazard Quotients were marginally above 1 in the plume for Lake Trout and White Sucker, but were less than or equal to reference values for both species. Therefore, it is unlikely that there are any effects arising from the thermal plume in the lake for juvenile or adult stages of any fish species.

Entrainment and Impingement

In 2009, in response to an order by the CNSC to reduce impingement by 80%, OPG installed a fish diversion system consisting of a barrier net surrounding the intake structure of PN. No reasonable technological solution is available to reduce entrainment by 60% (OPG, 2012h), but these losses are more than offset by operation of the fish diversion system and by OPG support for projects to create Northern Pike spawning and nursery habitat (OPG, 2012h), and by OPG participation in the Bring Back the Salmon Program (Lake Ontario Atlantic Salmon Restoration Program, 2011).

Overall, reductions in impinged biomass from 2011 to 2015 are considered to meet or exceed the 80% reduction target.

Recommendations

Based on the results of the ERA, some recommendations have been proposed.

Although site soil data from 2015 confirms localized areas of contamination no specific monitoring or remediation is recommended at this stage, as the contamination will be addressed during decommissioning of the PN site. According to the preliminary decommissioning plan for the PN site all contamination exceeding the established clearance levels for a 'brown field' site will be removed from the site or remediated on site in order to restore the site to a state suitable for other OPG uses (OPG, 2016f).

As identified in the 2014 ERA, the only exposure pathway for receptors at Hydro Marsh is through airborne deposition of tritium from atmospheric emissions from PN. Sampling of water at Hydro Marsh could be performed to confirm that effects from tritium deposition in the marsh are minor. This one time supplementary study is being conducted as part of the EMP in the 2016 sampling year. The results will be available in the 2016 EMP report published in 2017.

To further assess the potential for thermal effects to Round Whitefish embryos in the thermal plume over the period of continued operation of PN, it is recommended that a thermal monitoring study be conducted in the vicinity of the PN U5-8 CCW discharge to confirm the predictions made in the ERA and the associated potential effects on the survival of Round Whitefish embryos. The study is to be conducted during one winter season (December to April). The thermal monitoring study and the effects assessment on Round Whitefish survival will be incorporated into the next ERA update.

Conclusion

Overall, the PN site is operating in a manner that is protective of human and ecological receptors residing in the surrounding area.

TABLE OF CONTENTS

	<u>Page</u>
1.0 INTRODUCTION	1.1
1.1 Background.....	1.1
1.1.1 Review of Past Environmental Assessments	1.1
1.1.2 Review of Past ERAs.....	1.4
1.1.3 Review of 2014 ERA.....	1.5
1.1.4 Baseline Sampling Program.....	1.6
1.2 Goals, Objectives and Scope	1.9
1.3 Quality Assurance and Quality Control.....	1.12
1.4 Periodic Review of the ERA	1.12
1.5 Organization of Report.....	1.14
2.0 SITE DESCRIPTION	2.1
2.1 Site History	2.1
2.2 Engineered Site Facilities.....	2.4
2.2.1 Site Overview.....	2.4
2.2.2 Materials Management.....	2.17
2.3 Description of the Natural and Physical Environment.....	2.30
2.3.1 Meteorology and Climate	2.30
2.3.2 Geology	2.36
2.3.3 Hydrogeology.....	2.39
2.3.4 Hydrology	2.45
2.3.5 Vegetation Communities	2.55
2.3.6 Aquatic Communities	2.68
2.3.7 Human Land Use.....	2.77
2.3.8 Population Distribution	2.79
3.0 HUMAN HEALTH RISK ASSESSMENT	3.1
3.1 Problem Formulation.....	3.1
3.1.1 Receptor Selection and Characterization	3.1
3.1.2 Selection of Chemical, Radiological, and Other Stressors.....	3.3
3.1.3 Selection of Exposure Pathways.....	3.38
3.1.4 Human Health Conceptual Model	3.41
3.1.5 Uncertainties in the Problem Formulation	3.44
3.2 Exposure Assessment	3.45
3.2.1 Exposure Locations	3.45
3.2.2 Exposure Duration and Frequency.....	3.47

3.2.3	Exposure and Dose Calculations	3.47
3.2.4	Exposure Factors.....	3.48
3.2.5	Models	3.51
3.2.6	Exposure Point Concentrations and Doses	3.53
3.2.7	Uncertainties in the Exposure Assessment	3.62
3.3	Toxicity Assessment	3.63
3.3.1	Toxicological Reference Values (TRVs).....	3.63
3.3.2	Radiation Dose Limits and Targets	3.64
3.3.3	Uncertainties in the Toxicity Assessment	3.64
3.4	Risk Characterization	3.64
3.4.1	Risk Estimation	3.64
3.4.2	Discussion of Chemical and Radiation Effects	3.66
3.4.3	Uncertainties in the Risk Characterization.....	3.69
4.0	ECOLOGICAL RISK ASSESSMENT	4.1
4.1	Problem Formulation.....	4.1
4.1.1	Receptor (VEC) Selection and Characterization	4.3
4.1.2	Assessment and Measurement Endpoints	4.8
4.1.3	Selection of Chemical, Radiological, and Other Stressors.....	4.9
4.1.4	Selection of Exposure Pathways.....	4.38
4.1.5	Ecological Conceptual Model.....	4.39
4.2	Exposure Assessment	4.44
4.2.1	Exposure Points.....	4.44
4.2.2	Exposure Averaging.....	4.45
4.2.3	Exposure and Dose Calculations	4.46
4.2.4	Dispersion Models	4.63
4.2.5	Exposure Point Concentrations and Doses	4.63
4.2.6	Uncertainties in the Exposure Assessment	4.80
4.3	Effects Assessment	4.82
4.3.1	Toxicological Benchmarks	4.82
4.3.2	Radiation Benchmarks.....	4.88
4.3.3	Thermal Benchmarks.....	4.89
4.3.4	Uncertainties in the Effects Assessment	4.90
4.4	Risk Characterization	4.91
4.4.1	Risk Estimation	4.91
4.4.2	Discussion of Chemical and Radiation Effects	4.95
4.4.3	Thermal Effects.....	4.100
4.4.4	Entrainment/Impingement	4.111
4.4.5	Uncertainties in the Risk Characterization.....	4.117

5.0	CONCLUSIONS AND RECOMMENDATIONS	5.1
5.1	Conclusions	5.1
5.1.1	Conclusions of Human Health Risk Assessment (HHRA)	5.1
5.1.2	Results of Ecological Risk Assessment (EcoRA)	5.3
5.2	Recommendations for the Monitoring Program	5.10
5.3	Risk Management Recommendations	5.11
6.0	REFERENCES	6.1
Appendix A	Screening Tables Used for the HHRA and EcoRA	A.1
Appendix B	Ecological Receptor Profiles	B.1
Appendix C	Limiting Gross Beta/Gamma Radionuclides for Ecological Receptors..	C.1
Appendix D	Sample Calculations	D.1
Appendix E	Assessment of Station Contribution to Observed Concentrations at Frenchman’s Bay	E.1
Appendix F	Summary of Data from Baseline Environmental Sampling Program.	F.1
Appendix G	Stormwater Runoff Calculations	G.1

LIST OF TABLES

Table 1.1: Follow-Up Monitoring Program from PARTS EA.....	1.2
Table 1.2: Summary of 2014 ERA Recommendations and Follow-up Action Taken.....	1.5
Table 1.3: Summary of Baseline Sampling Program for the ERA.....	1.8
Table 1.4: Summary of Results of Periodic Review of the ERA.....	1.13
Table 2.1: In-Service Dates for PN U1-4 and U5-8.....	2.1
Table 2.2: In-Service Dates for PWMF Phase 1 and Phase II Sites.....	2.2
Table 2.3: Chemical Usage and Disposal.....	2.18
Table 2.4: MISA Monitoring Requirements.....	2.25
Table 2.5: ECA Monitoring Requirements.....	2.26
Table 2.6: Modelled Sources and Associated Contaminants.....	2.28
Table 2.7: Temperature Normals near Pickering Nuclear.....	2.32
Table 2.8: Precipitation from the Oshawa Climate Station (1981 – 2010) (Government of Canada, 2016).....	2.33
Table 2.9: Lake Current Data from 2011 to 2015.....	2.46
Table 2.10: Current Speed and Direction from 2011 to 2015.....	2.47
Table 2.11: Nearshore Mean Monthly Ambient Temperatures (°C) for Lake Ontario for the 1970-1988 Period (Golder, 2007a).....	2.48
Table 2.12: Estimated Area of the Surface, Middle and Bottom Thermal Plumes (10°C above the Units 5-8 Intake Temperature) during Algal Events Observed in 2006 and 2007.....	2.50
Table 2.13: Plant Species at Risk Observed within the PN Site Area (OPG, 2016a; TRCA, 2014).....	2.62
Table 2.14: Bird Species Observed During the 2009 to 2015 Terrestrial Long Term Monitoring Project.....	2.63
Table 2.15: Terrestrial Animal Species at Risk Observed within the PN Site (OPG, 2016a).....	2.68
Table 2.16: Fish Species at Risk Observed within the PN Site Area (OPG, 2016a).....	2.73
Table 2.17: Common and Scientific Names of Resident and Migratory Fish Species at PN (Golder, 2007b).....	2.74
Table 2.18: Water Supply Plant Information (OPG, 2013b).....	2.79
Table 2.19: Population Distribution Surrounding PN Based on 2011 Census Data (OPG, 2013b).....	2.81
Table 3.1: Summary of CCW Mixing Calculations for RLWMS and NWTP.....	3.9
Table 3.2: Lake Surface Water 2015 Sampling Locations and Descriptions.....	3.10
Table 3.3: Radioactive Emissions from PN.....	3.20
Table 3.4: Expected Dose Rates at Boundary Locations from PWMF Phase I and Phase II.....	3.24
Table 3.5: Sound Level Limits for Class 1 and Class 2 Areas.....	3.27
Table 3.6: Noise Monitoring Locations and Descriptions.....	3.27
Table 3.7: Environmental Noise (human receptors) – NM-1 Long-term Unattended Noise Monitoring Data Results.....	3.28
Table 3.8: Environmental Noise (human receptors) – NM-2 Long-term Unattended Noise Monitoring Results.....	3.30

Table 3.9: Environmental Noise (human receptors) – NM-3 Long-term Unattended Noise Monitoring Results	3.32
Table 3.10: Environmental Noise (human receptors) –Short-term Attended Noise Monitoring Results	3.36
Table 3.11: Summary of COPCs Selected for the HHRA	3.38
Table 3.12: Complete Exposure Pathways for Relevant Receptors for Exposure to Non-Radiological COPCs	3.40
Table 3.13: Complete Exposure Pathways for Relevant Receptors for Exposure to Radiological COPCs	3.40
Table 3.14: Distance and Wind Sector of Potential Critical Groups	3.45
Table 3.15: Human Exposure Factors for Radiological Dose Calculations	3.48
Table 3.16: Human Exposure Factors for Non-Radiological Dose Calculations.....	3.51
Table 3.17: Radionuclide and Pathway Data Used in the Dose Calculations (OPG, 2016c)	3.52
Table 3.18: Summary of Dose to Critical Group from 2011 to 2015.....	3.54
Table 3.19: Maximum Annual Dose to Sport Fisher from PWMF Phase I and Phase II ..	3.55
Table 3.20: Summary of Exposure Point Concentrations for Relevant Receptors, Pathways and Non-Radiological COPCs.....	3.58
Table 3.21: Dose to Urban Resident and Commercial/Industrial Worker from Water Ingestion	3.60
Table 3.22: Dose to Sport Fisher due to Fish Ingestion	3.60
Table 3.23: Dose to Receptors due to Hydrazine Inhalation.....	3.61
Table 3.24: Summary of Major Uncertainties in the Exposure Assessment.....	3.62
Table 3.25: Selected Human Toxicity Reference Values for Non-Radiological Risk Assessment	3.64
Table 3.26: Risk Estimates for Exposure to COPCs	3.66
Table 4.1: Criteria to Select Ecological Receptors (VECs)	4.4
Table 4.2: Summary of VECs and their Assessment Models used in the EcoRA	4.6
Table 4.3: Representative Species for Identified Species at Risk.....	4.7
Table 4.4: Frenchman’s Bay 2015 Sampling Locations and Descriptions.....	4.13
Table 4.5: 2015 Soil Sampling Locations and Descriptions	4.22
Table 4.6: Maximum Dose Rates in Close Proximity to PWMF Phase I and Phase II....	4.27
Table 4.7: Noise Monitoring Locations and Descriptions	4.31
Table 4.8: Environmental Noise (ecological receptors) Location ES-1 Long-term Unattended Noise Monitoring Results	4.32
Table 4.9: Environmental Noise (ecological receptors) Location ES-2 Long-term Unattended Noise Monitoring Results	4.32
Table 4.10: Environmental Noise (ecological receptors) Location ES-3 Long-term Unattended Noise Monitoring Results	4.32
Table 4.11: Environmental Noise (ecological receptors) Locations –Short-term Attended Noise Monitoring Results	4.33
Table 4.12: Environmental Compliance Approval Discharge Temperature Limits for Different Operating Conditions (OPG, 2011j)	4.35
Table 4.13: Summary of COPCs Selected for the Ecological Risk Assessment	4.38
Table 4.14: Complete Exposure Pathways for All Selected VEC Species	4.42
Table 4.15: Sediment Distribution Coefficients	4.46
Table 4.16: Bird and Mammal Body Weights and Intake Rates	4.51

Table 4.17: Receptor Occupancy Factors	4.52
Table 4.18: Bioaccumulation Factors (BAFs) for Fish, Amphibians, Benthic Invertebrates, and Aquatic Plants (L/kg fw).....	4.53
Table 4.19: Bioaccumulation Factors (BAFs) for Soil Invertebrates and Terrestrial Plants (kg-dw/kg-fw)	4.53
Table 4.20: Transfer Factors for Riparian Birds and Mammals (d/kg fw)	4.54
Table 4.21: Transfer Factors for Terrestrial Birds and Mammals (d/kg fw).....	4.55
Table 4.22: Dose Coefficients of Surrogate Receptors Used for Radiological Exposure Calculations	4.56
Table 4.23: Summary of BAFs for Tritium and Carbon-14	4.60
Table 4.24: Input Parameters for Specific Activity Calculations for Tritium and Carbon-14	4.61
Table 4.25: Stable Carbon Content for Food Types	4.61
Table 4.26: Summary of Transfer Factors for Tritium and Carbon-14.....	4.62
Table 4.27: Exposure Values for the PN Exposure Assessment	4.65
Table 4.28: Estimated Radiation Dose for Aquatic Biota at the Outfall (mGy/d).....	4.72
Table 4.29: Estimated Radiation Dose for Aquatic Biota at Frenchman's Bay (mGy/d) ..	4.73
Table 4.30: Estimated Radiation Doses for Terrestrial Biota at the PN Site (mGy/d).....	4.74
Table 4.31: Estimated Non-Radiological Dose for Riparian Birds and Mammals at PN Outfall and Frenchman's Bay (mg/kg·d)	4.78
Table 4.32: Estimated Non-Radiological Dose for Terrestrial Birds and Mammals at the PN Site (mg/kg·d)	4.79
Table 4.33: Summary of Major Uncertainties in the Ecological Exposure Assessment ...	4.81
Table 4.34: Sulphate Water Quality Guidelines based on Water Hardness	4.83
Table 4.35: Toxicological Benchmarks for Aquatic Receptors	4.85
Table 4.36: Toxicological Benchmarks for Benthic Invertebrates.....	4.86
Table 4.37: Toxicological Benchmarks for Soil for Terrestrial Invertebrates and Plants ..	4.87
Table 4.38: Selected Toxicity Reference Values for Mammals (Aquatic and Terrestrial)	4.87
Table 4.39: Selected Toxicity Reference Values for Birds	4.88
Table 4.40: Summary of Radiation Dose Estimates for Biota at the Pickering Site (mGy/d)	4.92
Table 4.41: Non-Radiological Hazard Quotients for Terrestrial Biota	4.93
Table 4.42: Non-Radiological Hazard Quotients for Aquatic Biota and Riparian Birds and Mammals	4.93
Table 4.43: Non-Radiological Hazard Quotients for Benthic Invertebrates from Sediment TRVs.....	4.94
Table 4.44: Thermal Criteria Relevant to Embryo and Larval Development of Selected Fish Species (Golder, 2007b)	4.100
Table 4.45: Thermal Criteria Relevant to Spawning and Embryo-Larval Development of Selected Fish Species (Cooper, 2013).....	4.102
Table 4.46: Thermal Hazard Quotients Relevant to Spawning and Embryo-Larval Development of Selected Fish Species in Lake Ontario near the PN U5-8 Discharge (Cooper, 2013).....	4.103
Table 4.47: Predicted Round Whitefish Egg Survival based on the Revised Hybrid Model and Winter Temperature Data at All Plume Stations (OPG, 2017)	4.106
Table 4.48: Thermal Criteria Relevant to Growth and Mortality of Selected Fish Species (Golder, 2007b).....	4.107

Table 4.49: Thermal Criteria Relevant to Juvenile and Adult Stages of Selected Fish Species (Cooper, 2013)	4.109
Table 4.50: Thermal Hazard Quotients Relevant to Juveniles and Adults of Selected Fish Species in Lake Ontario near the PN U5-8 Discharge (Cooper, 2013).	4.110
Table 4.51: Entrainment/Impingement at PN before the FDS (Golder, 2007g)	4.112
Table 4.52: Entrainment/Impingement at PN before the FDS (SENES, 2009).....	4.113
Table 4.53: Impinged Biomass and Percent Reduction in 2010 and 2012 (OPG, 2013e, 2014b, 2015c, 2016b)	4.115
Table 5.1: Summary of Annual Dose to Critical Group from 2011 to 2015.....	5.2

LIST OF FIGURES

Figure 1.1: Local and Regional Study Area (SENES, 2007e)	1.11
Figure 2.1: PN Site Location and Vicinity (Golder and EcoMetrix, 2017)	2.3
Figure 2.2: Pickering Nuclear Generating Station.....	2.11
Figure 2.3: Pickering Waste Management Facility Layout and Surrounding Buildings ...	2.12
Figure 2.4: Photo of Installed Fish Diversion System from the East Side Looking West (OPG, 2012h).....	2.13
Figure 2.5: Pickering Nuclear Site Water Balance (modified from Golder, 2007a).....	2.16
Figure 2.6: Simplified Radioactive Liquid Waste Management System Flow Diagram (OPG, 2000a).....	2.22
Figure 2.7: Non-radiological Air Emissions Sources (Golder, 2011)	2.29
Figure 2.8: Average Monthly Temperatures Reported at the PN Meteorological Station (2011-2015)	2.31
Figure 2.9: Comparison of Total Monthly Precipitation for Three Regional Meteorological Stations.....	2.34
Figure 2.10: 2011 - 2015 Annual Average Windrose at 10-m Tower	2.35
Figure 2.11: Subsurface Conditions Beneath the PN Site and Offshore Section A-A' (Golder, 2007d).....	2.37
Figure 2.12: Bedrock Surface Topography beneath the PN Site and Offshore (Golder, 2007d).....	2.38
Figure 2.13: Site Groundwater Flow Conditions – Shallow Groundwater Elevation Contours (OPG, 2016d).....	2.43
Figure 2.14: Site Groundwater Flow Conditions – Intermediate Groundwater Elevation Contours (OPG, 2016d)	2.44
Figure 2.15: Local Study Area for Surface Water Resources, Local Watersheds and Drainage Boundaries (Golder, 2007a).....	2.52
Figure 2.16: PN Site Plan (Golder, 2007a)	2.53
Figure 2.17: Catchment Areas for Pickering Nuclear and Stormwater Sampling Locations	2.54
Figure 2.18: Vegetation Communities Within and in the Vicinity of the PN Site (Golder, 2007c).....	2.56
Figure 2.19: Terrestrial Monitoring Plots within the PN Site (TRCA, 2014)	2.57
Figure 2.20: Aquatic Site Study Area (Golder, 2007b)	2.69
Figure 2.21: Aquatic Local Study Area (Golder, 2007b).....	2.70

Figure 3.1: Modelled Annual Hydrazine Atmospheric Concentration at Locations around the PN Site (OPG, 2015e).....	3.6
Figure 3.2: 2015 Lake Surface Water Sample Collections.....	3.12
Figure 3.3: Locations of the 2014 Hydrazine Sample Collections near the PN Site (22 July, 15 August and 10 September)	3.13
Figure 3.4: Summary of PN Emissions Data from 2011-2015	3.21
Figure 3.5: NM-1 Long-term Unattended Noise Monitoring L_{Aeq} (1-h) Overall Results	3.29
Figure 3.6: NM-1 Long-term Unattended Noise Monitoring L_{A90} (1-h) Overall Results	3.30
Figure 3.7: NM-2 Long-term Unattended Noise Monitoring L_{Aeq} (1-h) Overall Results	3.31
Figure 3.8: NM-2 Long-term Unattended Noise Monitoring L_{A90} (1-h) Overall Results	3.32
Figure 3.9: NM-3 Long-term Unattended Noise Monitoring L_{Aeq} (1-hr) Overall Results ...	3.33
Figure 3.10: NM-3 Long-term Unattended Noise Monitoring L_{A90} (1-h) Overall Results ..	3.34
Figure 3.11: Environmental Noise Dataset (L_{Aeq} (1 h)).....	3.35
Figure 3.12: Environmental Noise (Human Receptors) - Long-term Unattended and Short-term Attended Noise Monitoring Locations	3.37
Figure 3.13: Generic Conceptual Model for Human Receptors (CSA, 2008)	3.43
Figure 3.14: Locations of Human Receptors – Potential Critical Groups (OPG, 2016c)..	3.46
Figure 4.1: Area of Assessment for Ecological Risk Assessment	4.2
Figure 4.2: North Frenchman’s Bay 2015 Sampling Locations	4.16
Figure 4.3: South Frenchman’s Bay 2015 Sampling Locations	4.17
Figure 4.4: Surface Water Sampling Points for the East Landfill Perpetual Care Program (OPG, 2011f).....	4.20
Figure 4.5: 2015 Soil Sampling Locations on Pickering Nuclear Site	4.24
Figure 4.6: Environmental Noise (Ecological Receptors) - Long-term Unattended and Short-term Attended Noise Monitoring Locations	4.34
Figure 4.7: Conceptual Model for the Terrestrial Environment.....	4.40
Figure 4.8: Conceptual Model for the Aquatic Environment.....	4.41
Figure 4.9: Generic Conceptual Model for Relationships between Individual Endpoints and Population/Community Endpoints (CSA, 2012)	4.44
Figure 4.10: Radiological Dose Breakdown for Receptors at the Outfall.....	4.75
Figure 4.11: Radiological Dose Breakdown for Receptors at the PN Site	4.76
Figure 4.12: Radiological Dose Breakdown for Receptors at Frenchman’s Bay	4.77
Figure 4.13: Relationship between Sulphate Toxicity and Water Hardness (BC MOE, 2013)	4.84
Figure 4.14: Estimated areal extent of potential changes in relative survival loss of Round Whitefish embryos at Pickering Nuclear based on substrate temperatures for a spawning date of 1 December, 2011	4.105

1.0 INTRODUCTION

1.1 Background

The *Nuclear Safety and Control Act* (NSCA) mandates the Canadian Nuclear Safety Commission (CNSC) to regulate the nuclear industry in a manner that prevents unreasonable risk to the environment and makes adequate provision for environmental protection, in conformity with international obligations. This mandate is reflected in the General Nuclear Safety and Control Regulations under the NSCA, and in the CNSC (2001) Regulatory Policy on Protection of the Environment. This policy indicates that licence applicants will be required to “demonstrate through performance assessments, monitoring, or other evidence, that their provisions to protect the environment are adequate”.

The Canadian Standards Association (CSA) has recently completed its N288.6-12 standard on environmental risk assessment (ERA) for Class I nuclear facilities (CSA, 2012). The standard calls for both ecological risk assessment (EcoRA) and human health risk assessment (HHRA), for both radiological and non-radiological contaminants and physical stressors. The CSA has recently completed its N288.4 (2010) and N288.5 (2011) standards on environmental monitoring programs (EMP) and effluent monitoring programs. These standards recommend that effluent and environmental programs are designed, in part, to address risk issues identified by ERA. These programs can also inform the ERA by providing information on effluent concentrations and loadings, and by providing environmental data to assist in model calibration and validation.

1.1.1 Review of Past Environmental Assessments

Pickering A Return to Service Environmental Assessment:

In 2000, an environmental assessment (EA) was prepared under the Canadian Environmental Assessment Act (CEAA) to return PN Generating Station A (U1-4) to service (OPG, 2000a). The Commission issued its decision on the environmental assessment in February 2001. Based on the information contained in the EA, and taking the proposed mitigation measures into account, the CNSC decided that the return to service of PNGS-A was not likely to cause significant adverse environmental effects. Following their decision, the CNSC amended the operating licence to allow the station to restart after identified improvements and upgrades to the station had been completed (CNSC, 2001).

As part of their decision on the EA, the CNSC identified the requirement for a Follow-Up and Monitoring Program (FUMP). The FUMP was established for pre-restart and post-restart conditions to provide information on minimizing adverse effects and ensuring effective environmental protection measures were implemented (OPG, 2001). The FUMP consisted of activities to confirm before and after return to service. The implementation of the FUMP was reported in a series of annual monitoring reports provided to the CNSC.

Follow-Up and Monitoring Program includes the following program elements (Table 1.1):

Table 1.1: Follow-Up Monitoring Program from PARTS EA

Environmental Assessment Component	Effects to be Managed	Element Number
Radiation and Radioactivity	General Public (Individual Doses)	1.1
Atmospheric Environment	Air Quality (Steam and Feedwater System)	2.1
Hydrology and Water Quality	Lake Water Quality (Malfunctions and Accidents)	3.1
	Lake Water Quality (Operation of MWSS and RLWMS)	3.2
	Near-Shore Flow Circulation (Operation of condenser cooling water (CCW) System)	3.3
	Water Temperature (Operation of CCW and MWSS)	3.4
	Sedimentation (Operation of CCW system)	3.5
	Surface Water Runoff Quality (Site Drainage)	3.6
Aquatic Environment	Aquatic Habitat and Aquatic Biota (Impingement)	4.1
	Aquatic Habitat and Aquatic Biota (Entrainment)	4.2
	Aquatic Habitat and Aquatic Biota (Temperature and Velocity)	4.3
	Aquatic Habitat and Aquatic Biota (Fishing Pressure)	4.4
Terrestrial Environment	Wildlife Communities (Land Transportation Activities)	5.1
Geology, Hydrogeology and Seismicity	Groundwater Quality (General)	6.1
	Groundwater Quality (Malfunctions and Accidents – Tritium)	6.2
	Physical Environment (Seismic Events)	6.3
Land Resources	Transportation and Network Elements (Level of Service – Hwy 401)	7.1
	Transportation and Network Elements (Level of Service – Bayly Street)	7.2
Socio-Economic Conditions	Residents and Communities (Satisfaction with Community)	8.1
	Community Infrastructure (Housing and Property Values)	8.2
Emergency Response Plan and Preparedness	Dose to Humans and Non-human Biota	9.1
Notes: MWSS: Miscellaneous Water Supply RLWMS: Radioactive Liquid Management System CCW: Condenser Cooling Water System		

The sixth and final FUMP report was submitted in May 2007, summarizing the 2006 monitoring program, and an overall summary of the results of the FUMP since inception in 2001, showing how these results confirm predictions made in the EA (OPG, 2007a). The CNSC staff completed a comprehensive review of the FUMP reports and accepted the completion of the follow-up monitoring program in October 2008 (CNSC, 2008a).

Pickering Waste Management Facility Phase II Environmental Assessment

In 2003, prior to PWMF expanding to a Phase II site, a screening level Environmental Assessment (EA) was conducted to provide additional storage capacity of used fuel in dry storage containers (OPG, 2003). The scope of the project included construction and operation of Dry Storage Container (DSC) storage buildings #3 and #4.

The results of the assessment identified no significant residual adverse environmental effects of the PWMF Phase II project with the proposed mitigation measures in place. In 2004, the CNSC Secretariat concluded that the project, taking into account the appropriate mitigation measures identified in the Screening Report, was not likely to cause significant adverse environmental effects, and approved the EA (CNSC, 2004).

As part of the PWMF Phase II project, OPG submitted an Environmental Assessment follow-up monitoring program which outlined the monitoring requirements for the project (OPG, 2005a). The EA follow-up monitoring program included monitoring related to stormwater management, visual screening and public attitudes.

Stormwater drainage was monitored during the construction of DSC Storage Building #3 which included daily inspection of storm water, erosion, and check dam. The constructor's records indicate that there were no significant problems with storm water drainage (OPG, 2010f).

To address concerns raised with respect to views of the proposed facility from the Waterfront Trail which passes by the eastern boundary of the Pickering nuclear property, original plantings along the east perimeter fence of the Pickering Nuclear site were substituted with larger, more mature trees which enhanced the screening and have better survival rates. With respect to the public attitude research survey, the results from the 2009 survey were compared to the results from the 2002 survey. The results suggest that the PWMF Phase II project did not result in a change in attitude in the local community.

Pickering B Refurbishment and Continued Operation Environmental Assessment:

As part of its planning process, OPG conducted an EA study for the PN Units 5-8 Project to refurbish one or more of the PN Units 5-8 reactors. The scope of the EA included the construction and operation of additional waste storage structures to accommodate wastes resulting from reactor refurbishment activities, and from on-going operation of the reactors.

The EA study report and nine technical supporting documents (TSDs) were submitted to the CNSC in December 2007 (OPG, 2007b). After considering the screening report, the mitigation measures, and comments filed from the public, the CNSC Commission accepted that the project would not cause significant adverse effects (CNSC, 2009).

In 2010, OPG announced that it would not proceed with refurbishing the PN units. However, OPG is proceeding with the construction of a new DSC processing building and additional waste storage structures for used fuel, namely DSC Storage Buildings #5 and #6.

No specific EA follow-up activities related to the construction and operation of additional storage buildings were identified in the PN Units 5-8 Refurbishment and Continued Operation EA.

PN Units 2 & 3 Defueled State:

The four PNGS A reactors were placed in a Guaranteed Shutdown State at the end of 1997. Following PA RTS EA approval, Units 1 and 4 were returned to service. In August 2005, OPG announced that Units 2 and 3 would not be returned to service and will be placed in a Guaranteed Defuelled State as part of a broader Safe Storage Program, until such time as the entire Pickering A station is decommissioned.

In 2008, a screening level EA was prepared under CEAA to place Units 2 and 3 in a Guaranteed Defuelled State (OPG, 2008). Taking into account the findings of the EA including the identified mitigation measures, the proposed Guaranteed Defuelled State Project will not result in any significant adverse environmental effects. The permanent removal of Units 2 and 3 from operation, and lay the units up in a guaranteed defueled, drained and dried condition, was confirmed by the CNSC in December 2008 to have no increase in risk over the existing operation (CNSC, 2008b).

1.1.2 Review of Past ERAs

A multi-tiered EcoRA was performed from 1999 to 2002 (SENES, 1999; 2000; 2001; 2002) to assess the overall ecological effect of operations at the Pickering Nuclear (PN) site and to support regulatory compliance. In the first phase an issue-based Environmental Review was completed in 1998 and submitted to the CNSC (then the Atomic Energy Control Board). The CNSC recommended that a screening EcoRA be performed to identify any effects the PN Generating Station has on the valued ecosystem components (VECs). A multi-tiered risk assessment was completed in response to CNSC recommendations. The Tier 1 risk assessment identified some data gaps and areas of uncertainty that were then further resolved in the Tier 2 and Tier 3 risk assessments. Although the focus of the risk assessments was on ecological receptors, some human receptors were evaluated as well. Based on the results of the Tier 1, 2, and 3 assessments, no significant ecological effects from existing chemical or radiological releases from PN were identified. The Tier 3 risk assessment recommended environmental monitoring of water and sediment in Hydro Marsh to characterize the current conditions or estimate the potential release of metal

inventories from sediment back into the water column. The risk assessment also recommended some environmental monitoring including surface water, groundwater, soil, and fish to confirm assumptions and reduce uncertainty in the calculations.

In 2007 to support the Pickering B Refurbishment and Continued Operations Environmental Assessment the ecological risk assessment was updated and a human health assessment was performed (SENES, 2007a, 2007b). The ecological risk assessment concluded no significant adverse effects to non-human biota due to releases of chemicals or radionuclides to the environment during existing conditions or during refurbishment and continued operations. The human health risk assessment also concluded no significant adverse effects to the public due to releases of chemicals or radionuclides to the environment during existing conditions or during refurbishment and continued operations. A follow up on site-specific risk assessment of non-potable groundwater was also conducted in 2007. No adverse effects to human health were identified based on the groundwater pathway for tritium. Additionally, to assess ecological risk a conservative assessment of a hypothetical earthworm in groundwater was assessed for tritium. The results indicated no adverse effects to ecological populations.

1.1.3 Review of 2014 ERA

In 2014, an integrated EcoRA and HHRA was prepared to be compliant with CSA N288.6-12 guidance. The CSA N288.6-12 compliant ERA focused on monitoring data from the five-year period 2007 to 2011 (EcoMetrix, 2014). The ERA identified a number of areas where supplementary monitoring studies were recommended in order to clarify risk and reduce uncertainty in future human health and ecological risk assessments. The specific recommendations and the actions taken to address the recommendations are summarized in Table 1.2. These supplementary studies were recommended as one-time studies and would only be part of the monitoring program until the objectives were achieved.

Table 1.2: Summary of 2014 ERA Recommendations and Follow-up Action Taken

2014 ERA Recommendation	Action Taken
An updated soil monitoring program on-site should be performed, focused on areas with historically elevated concentrations of tritium and a number of metals (including arsenic, cadmium, copper, lead, thallium, and zinc), to help reduce uncertainty regarding concentrations used in dose calculations for ecological receptors.	Soil sampling occurred as part of the 2015 baseline environmental sampling program.
Lake water samples should be collected along the PN U1-4 and PN U5-8 discharge channels and analyzed for hydrazine at a lower detection limit to reduce the uncertainty surrounding human exposure to hydrazine through drinking water.	Water samples were collected for hydrazine analysis in a 2014 EMP supplementary study (EcoMetrix, 2015).

2014 ERA Recommendation	Action Taken
Phosphorous-32 measurements in fish (and potentially sediment) should be obtained, if possible. However, since site-specific data exists for fish and sediment, Cesium-137 should continue to be used to represent gross beta/gamma radionuclides for human dose calculations.	OPG decided not to proceed with monitoring Phosphorous-32. Effluent characterization data from PN indicated that concentrations of Phosphorous-32 in the effluent were at or below detection limits, which are lower than the dominant gamma emitters in active liquid waste, such as Cesium-137 and Cobalt-60. The likelihood of detecting Phosphorous-32 in fish is extremely low and its short half-life presents analytical limitations.
Sampling of sediment and water in the northern section of Frenchman's Bay should be performed to reduce uncertainty regarding the assessment of biota in the bay. The Frenchman's Bay wetland is located in the northern section of the bay; however, previously, biota were assessed at the mouth of the bay where sediment data were available, and where waterborne emissions from PN have the greatest impact.	Sediment and surface water sampling occurred as part of the 2015 baseline environmental sampling program.
The only exposure pathway for receptors at Hydro Marsh is through airborne deposition of tritium from atmospheric emissions from PNGS. Sampling of water at Hydro Marsh could be performed to confirm that effects from tritium deposition in the marsh are minor.	An EMP supplementary study for Hydro Marsh will occur in 2016 and will be reported in the 2016 EMP Report.

1.1.4 Baseline Sampling Program

In order to address the recommendations from the 2014 ERA (EcoMetrix, 2014), OPG undertook a number of supplementary studies in 2014 and 2015.

In the summer of 2014, water samples were collected for hydrazine analysis at locations near the PN discharge channels and at downstream locations (EcoMetrix, 2015).

Considering the age of site environmental data and recent site alteration due to the development of Building #3 for the Pickering Waste Management Facility (PWMF), an updated baseline environmental sampling program was undertaken in 2015/2016 to reduce uncertainty in the ERA and to support future licensing activities. The baseline environmental sampling program included collection of:

- Lake surface water data;
- Sediment and surface water data from Frenchman's Bay;

- Stormwater data;
- Soil data; and
- Noise data.

A general overview of the baseline sampling program is provided in Table 1.3. All data collected as part of the baseline sampling program are provided in Appendix F or summarized within the report as required.

This ERA document provides an update to the 2014 ERA using recent monitoring data from the five-year period 2011 to 2015. This ERA is consistent with the CSA N288.6-12 standard. This risk assessment is not a probabilistic risk assessment. A probabilistic risk assessment is not required by the CSA N288.6-12 standard. Therefore, uncertainty discussions presented in this risk assessment are qualitative and semi-quantitative.

Table 1.3: Summary of Baseline Sampling Program for the ERA

Sample Medium	Location	Radiological Parameters	Non-Radiological Parameters	Rationale for Monitoring
Surface Water	Lake Ontario (nearshore)	Tritium, carbon-14, cobalt-60, cesium-134, cesium-137	Hydrazine ⁽¹⁾ , alkalinity, ammonia (total and un-ionized), biochemical oxygen demand, chemical oxygen demand, hardness, pH, conductivity, temperature, total suspended solids, total residual chlorine (in-situ), petroleum hydrocarbons, morpholine, metals	To address recommendation in 2014 ERA for hydrazine at a lower detection limit to reduce the uncertainty. To update the ERA and support future ERAs and the predictive effects assessment.
	Frenchman's Bay	Tritium, carbon-14, cobalt-60, cesium-134, cesium-137	Alkalinity, ammonia (total and un-ionized), biochemical oxygen demand, chemical oxygen demand, hardness, pH, conductivity, temperature, total suspended solids, total residual chlorine (in-situ), petroleum hydrocarbons, morpholine, metals, total organic carbon	To address recommendation in 2014 ERA.
Sediment	Frenchman's Bay	Carbon-14, cobalt-60, cesium-134, cesium-137	Particle size, total organic carbon, metals	To address recommendation in 2014 ERA.
Stormwater	PN site	Tritium, carbon-14, cobalt-60, cesium-134, cesium-137	Hardness, pH, conductivity, phosphorus, chloride, total suspended solids, petroleum hydrocarbons, metals, toxicity	To update the ERA and support future ERAs and the predictive effects assessment.
Soil	PN site	Tritium, carbon-14, cobalt-60, cesium-134, cesium-137	Polycyclic aromatic hydrocarbons, volatile organic compounds, petroleum hydrocarbons, metals and inorganics, glycol	To address recommendation in 2014 ERA to collect updated soil data.
Noise	PN site and Vicinity	Noise data		To update the ERA and support future ERAs and the predictive effects assessment.

Note:

(1) Hydrazine was analyzed in water samples collected in 2014 as part of a supplementary study (EcoMetrix, 2015).

1.2 Goals, Objectives and Scope

The overall goals of this ERA are:

- To establish an updated baseline condition for the Pickering Nuclear (PN) site.
- To support the assessment of future shutdown and safe storage of PN.
- To update the ERA in general accordance with the CSA N288.6-12 Standard.
- To provide focus for the environmental monitoring program on relevant contaminants of potential concern (COPCs), media, and ecological and human receptors.

The specific objectives of this ERA, consistent with CSA N288.6-12 are:

- To evaluate the risk to relevant human and ecological receptors resulting from exposure to contaminants and stressors related to the PN site and its activities.
- To recommend potential further monitoring or assessment as needed based on the results of the ERA.

The scope of the ERA encompasses normal operations at PN during the operations phase of the facility. It does not include decommissioning activities and does not address acute or high-level exposures resulting from accidents. The scope looks at the potential effects of releases from the facility on the human and ecological environment, as well as physical stressors. The ERA focuses on the five-year period from 2011 to 2015, but incorporates other years of data when necessary.

Spatial boundaries define the geographical extent(s) over which likely or potential environmental effects will be considered. The spatial scale for humans includes identified human receptors (potential critical groups) within 20 km of the PN site, which is part of the local study area (LSA) and part of the regional study area (RSA), see Figure 1.1. Consistent with the 2007 Pickering B Refurbishment for Continued Operation Environmental Assessment (EA), the LSA is composed of an area that extends approximately 10 km from PN. It is defined as an area which includes lands within the city of Pickering, the town of Ajax, and the eastern part of the City of Toronto (Scarborough). This study area also includes a portion of Lake Ontario abutting the property and used by those communities for activities such as recreation and community water supply and waste water discharge. The RSA extends beyond the LSA and extends approximately 20 km, to the Darlington Nuclear Generating Station in the east (i.e., the eastern boundary of the Region of Durham), to the eastern part of the City of Toronto (Scarborough) in the west, and including the municipalities in the Regional Municipality of Durham north of the PN site.

The spatial scale for ecological receptors includes receptors on-site and within the immediate site boundary and the near-field receiving waters, known as the site study area (SSA). Consistent with the 2007 Pickering B Refurbishment for Continued Operation EA, the SSA includes the facilities, buildings and infrastructure at the PN facility and the area

within the 914 metre exclusion zone for the site which encompasses both land surface and part of the Lake Ontario water surface. Figure 2.18 provides the terrestrial SSA and Figure 2.20 provides the aquatic SSA for ecological receptors. The aquatic SSA for ecological receptors includes the PN outfalls and Frenchman's Bay. The terrestrial SSA includes the PN site.

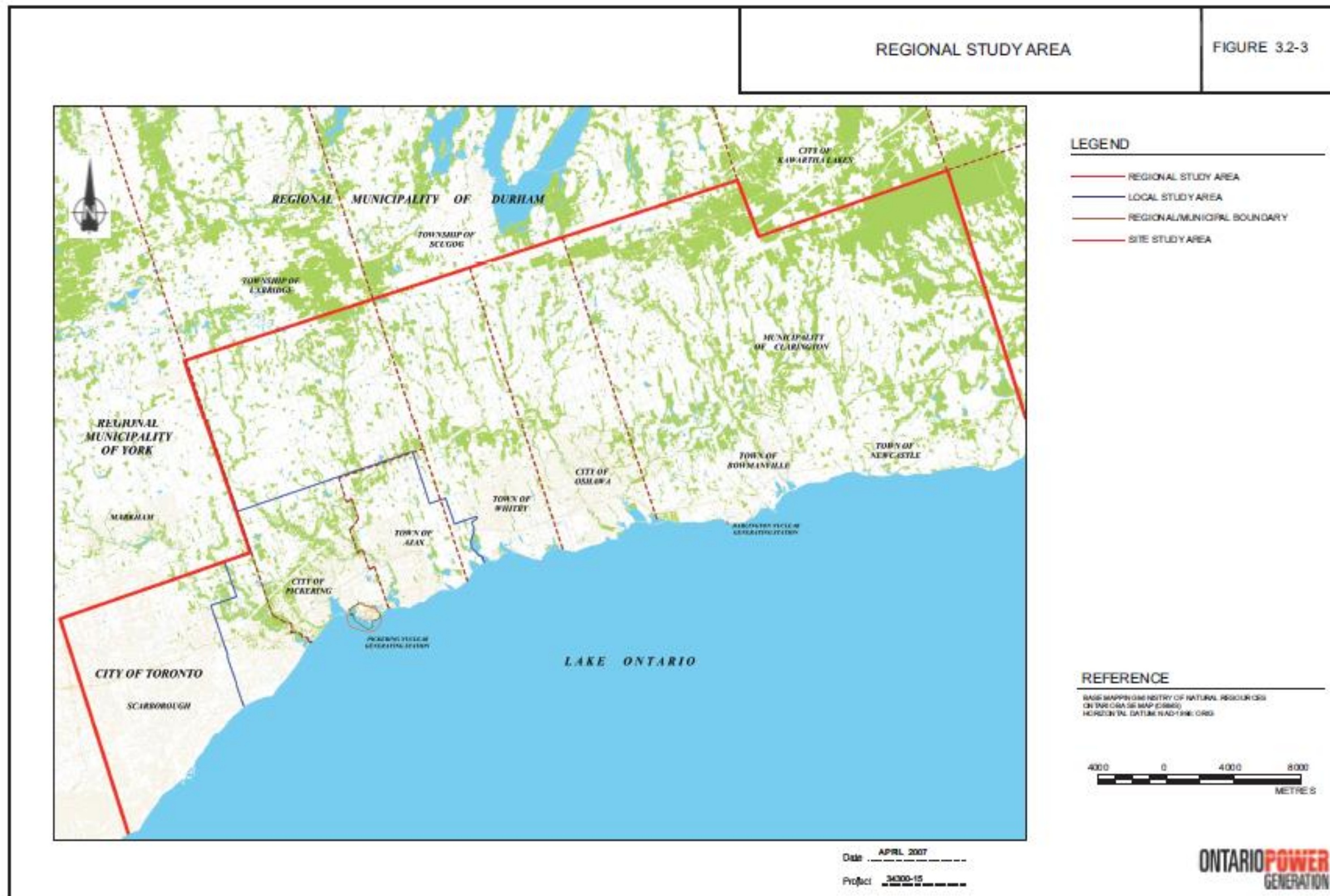

Figure 1.1: Local and Regional Study Area (SENES, 2007e)

1.3 Quality Assurance and Quality Control

The ERA makes extensive use of environmental monitoring data. These data are derived from chemical and radiochemical analyses of samples collected from effluent streams and environmental media around the PN site. The environmental data provided by Ontario Power Generation (OPG) were collected by qualified staff and analyzed by qualified performing laboratories under the EMP, such as the the station chemistry laboratory and the Whitby Health Physics Laboratory. The EMP has its own quality assurance (QA) program that encompasses activities such as sample collection, laboratory analysis, laboratory quality control, and external laboratory comparison (OPG, 2007c). Other samples such as water, sediment, soil, stormwater, and noise were collected as part of the updated baseline environmental sampling program for the PN ERA and Pickering Safe Storage Project Predictive Effects Assessment. These samples were collected and analyzed in accordance with the CSA N286-05 QA requirements for the project. Each sampling campaign involved preparation of a Sampling and Analysis Plan that outlined the data quality objectives, sampling and analysis protocol, required detection limits, roles and responsibilities, quality assurance and health and safety requirements. An inspection and test plan was completed at certain stages throughout the program to verify work was being completed as specified.

Samples collected as part of the updated baseline environmental sampling program for the PN ERA and Pickering Safe Storage Project Predictive Effects Assessment were analyzed by Maxxam Analytics and Kinectrics, which are both accredited by the Standards Council of Canada as conforming to the quality assurance requirements of ISO Standard 17025.

Throughout the planning and preparation of the ERA, all staff worked under an ISO 9001:2008 certified Quality Management System. All work was internally reviewed and verified. Reviews included verification of data and calculations, as well as review of report content. Comments have been dispositioned and addressed as appropriate by report revisions. The review process has been documented through a paper trail of review comments and dispositions.

1.4 Periodic Review of the ERA

The 2014 Pickering ERA (EcoMetrix, 2014), was reviewed according to the recommendations in Clause 11 of CSA N288.6-12, for periodic review of the ERA. The results of the periodic review are summarized in Table 1.4 and expanded in the referenced sections.

Table 1.4: Summary of Results of Periodic Review of the ERA

Periodic Review Element	Results from the 2011 to 2015 Period
Changes to site ecology or surrounding land use	Site ecology and surrounding land use focusing on the 2011 to 2015 period where available is detailed in Section 2.3. No major changes have occurred since the last ERA.
Changes to the physical facility or facility processes	A description of the physical facility and processes is provided in Section 2.2. No major changes have occurred since the last ERA.
New environmental monitoring data	An updated baseline monitoring program was conducted for PN which included collection of water, sediment, soil, stormwater, and noise data (see relevant subsections of 3.1.2 and 4.1.2).
New or previously unrecognized environmental issues	No new or previously unrecognized environmental issues have been identified. A review of radiological emissions data from 2011 to 2015 is presented in Section 3.1.2.5. Increased tritium airborne and waterborne emissions during parts of 2014 were related to leaks in valves or gaskets that have since been repaired.
Scientific advances	CANDU Owners Group (COG) developed a new model to assess the thermal impacts on round whitefish egg development and survival through controlled experiments using modern egg incubation techniques and more realistic thermal regimes. OPG used a revised version of the COG model to assess thermal impacts on Round Whitefish embryo survival (Section 4.4.3.1.1). Results from the Ontario Ministry of Natural Resources and Forestry (MNR) study on Round Whitefish supports the presence of a single panmictic population of Round Whitefish in Lake Ontario (Section 2.3.6.3)
Changes in regulatory requirements	None.

1.5 Organization of Report

The main sections of the ERA report, generally consistent with the suggested table of contents in CSA N288.6-12 (CSA, 2012), are as follows:

- Section 2.0: Site Description
- Section 3.0: Human Health Risk Assessment
- Section 4.0: Ecological Risk Assessment
- Section 5.0: Conclusions and Recommendations
- Section 6.0: References

2.0 SITE DESCRIPTION

2.1 Site History

The PN site is in the Province of Ontario, in the Regional Municipality of Durham, in the City of Pickering, on the north shore of Lake Ontario at Moore Point, about 32 km east of downtown Toronto and 21 km west of Oshawa at latitude 43° 49' N and longitude 79° 04' W. The site location and vicinity are shown in Figure 2.1.

The PN Units 1-4 (U1-4) and Units 5-8 (U5-8) are located on the PN site in the City of Pickering, Ontario. They are owned and operated by OPG. They are CANada Deuterium Uranium (CANDU) pressurized heavy water generating stations with four reactor units each, commissioned according to the schedule presented in Table 2.1. PN Units 2 and 3 have been de-fuelled and are in safe storage. PN U 1 and 4 and PN U5-8 have a total station net output of 1030 MWe and 2064 MWe, respectively (OPG, 2009a, 2012a). Since they have been placed in service, all PN units have operated safely. In 2015, PN produced 21.2 terawatt hours (TWh) of electricity. The production performance of PN stations was 78.3% of its rated capacity (OPG, 2016c).

Table 2.1: In-Service Dates for PN U1-4 and U5-8

Unit #	Net Electrical Output (MWe)	In-Service Date
Pickering A		
Unit 1	515	July 29, 1971
Unit 2	0	December 30, 1971 (de-fuelled as of 2007 and are in safe storage)
Unit 3	0	June 1, 1972 (de-fuelled as of 2008 and are in safe storage)
Unit 4	515	June 17, 1973
Pickering B		
Unit 5	516	May 10, 1983
Unit 6	516	February 1, 1984
Unit 7	516	January 1, 1985
Unit 8	516	February 26, 1986

The PWMF is also located on the PN site and is comprised of 2 sites. The PWMF Phase I site is located southeast of PN Unit 8, adjacent to the east side of the station security fence, and contains two used fuel dry storage buildings and a Retube Component Storage area.

The PWMF Phase II site is located approximately 500 m north-east of the power generating facilities in the East Complex, with its own distinct “protected area” (OPG, 2013a). The PWMF Phase II site contains one used fuel dry storage building with additional buildings planned, as required. The PWMF has been commissioned according to the schedule shown in Table 2.2.

Table 2.2: In-Service Dates for PWMF Phase 1 and Phase II Sites

Facility	In-Service Date
PWMF Phase I Site	
Stage 1 (DSC Storage Building #1, DSC processing building)	1996
Stage 2 (DSC Storage Building #2)	2001
Retube Component Storage Area	1984
PWMF Phase II Site	
DSC Storage Building #3 and security kiosk	Construction completed in 2009

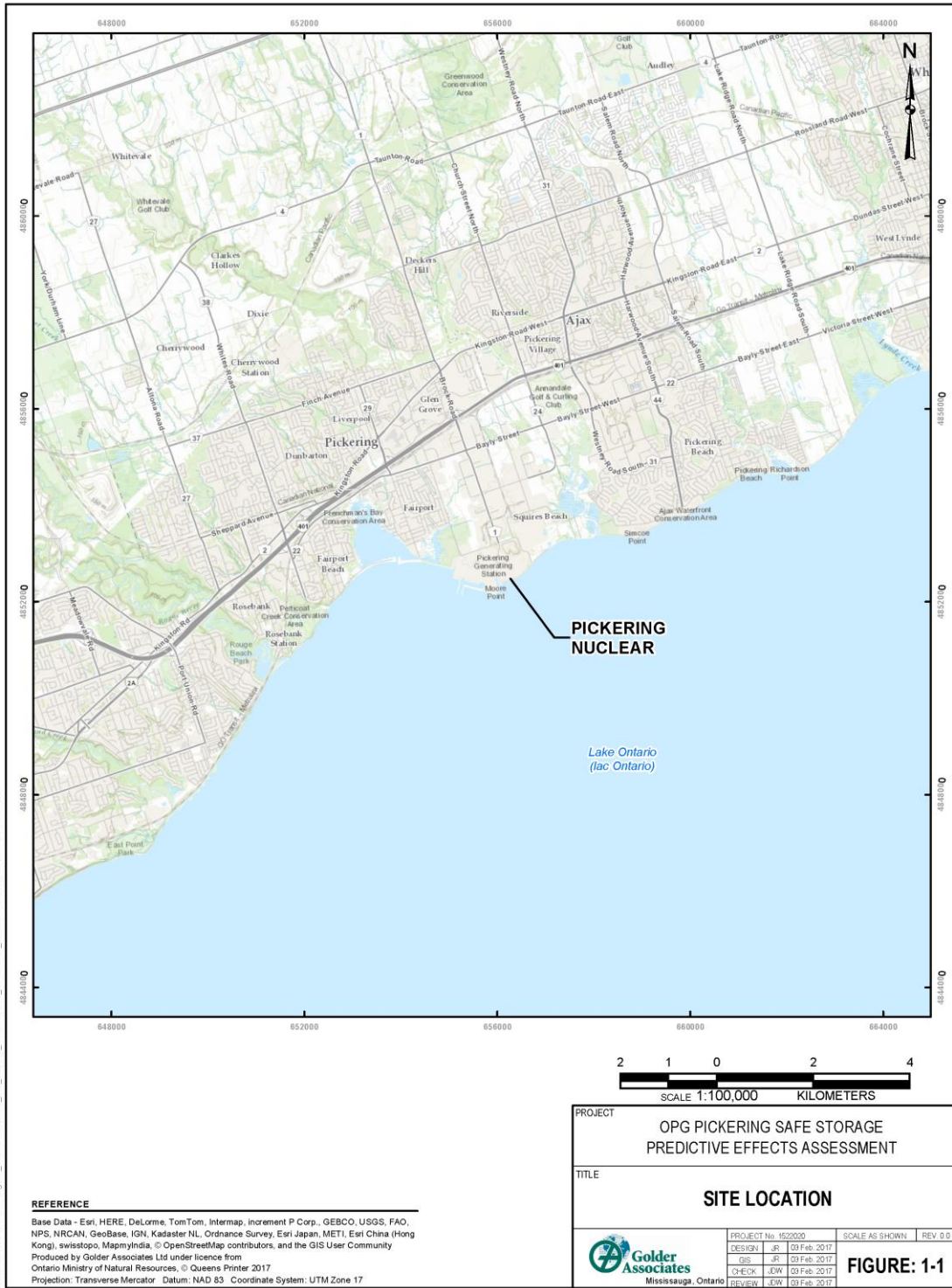

Figure 2.1: PN Site Location and Vicinity (Golder and EcoMetrix, 2017)

2.2 Engineered Site Facilities

An overview of each facility/operation and its releases is described in this section. Quantitative releases from the facilities/operations in both liquid and gaseous effluent are discussed in the Problem Formulation in Section 3.1.2 “Selection of Chemical, Radiological, and Other Stressors” and Appendix A.

2.2.1 Site Overview

The PN site comprises approximately 240 hectares and accommodates eight CANDU reactors. PN U1-4 are located on the west side, and PN U5-8 are on the east side. Units 2 and 3 were defueled in 2008 and are in safe storage. Power from the generating stations is delivered to the southern Ontario electrical grid.

PN U1-4 and U5-8 share the overall PN site as well as many services and facilities. An overview of the facilities on the PN site is presented in Figure 2.2 and identifies the major facilities and structures on the PN site. The principal PN buildings and a brief discussion of their purpose are described below:

Reactor buildings

The reactor buildings contain the reactors, control mechanisms, fuelling machines, heat transport system, steam generators, and auxiliary equipment. For PN U5-8, an emergency control center is located to the south of each reactor building under the pressure relief duct.

- Heat is generated by the release of neutrons from fissile uranium-235 (part of the overall natural uranium fuel bundles), the moderation of the neutrons within the deuterium (heavy water) and the further release of neutrons through fission of the fuel. This critical fission reaction generates heat.
- The heat transport system circulates pressurized heavy water through the reactor fuel channels to remove the heat produced from nuclear fission. This heat is then transferred to light water in the steam generators. The chemistry of the coolant heavy water is controlled through filtering, ion exchange, and chemical addition (see Table 2.3).
- The moderator system circulates heavy water through the calandria to thermalize or slow down the neutrons to increase the probability of fission. The moderator system also includes heat exchangers to remove heat generated from the thermalization process and maintain the temperature in the calandria to approximately 60°C.
 - Twelve steam generators per reactor transfer heat from the heavy water to light water. Steam flows through the main steam piping to the turbines in the powerhouse.

- When make-up water is required in the steam and feedwater system it is supplied from the demineralized water storage tanks from the New Water Treatment Plant. Feedwater pH and oxygen concentrations are controlled by hydrazine and morpholine addition, to limit dissolved solids and minimize corrosion. The concentration of dissolved solids in the light water is controlled by blowdown of steam generator light water (boiler blowdown).
- Each reactor building is equipped with a ventilation system which controls airflow and ambient temperatures in the accessible areas of the reactor building. Once through airflows are used to maintain a slight negative pressure in order to control the flow of air from low to high areas of contamination. All airborne emissions from the reactor buildings are controlled and monitored for radioactive contaminants by the stack monitoring system.

Reactor auxiliary bay

Each reactor auxiliary bay covers the full length of PN U1-4 and U5-8. These buildings house auxiliary systems and the irradiated fuel bays. Used fuel is initially stored in the irradiated fuel bays to allow for cooling. After this time used fuel is transferred to dry storage containers (DSCs) and transported to the Pickering Waste Management Facility (PWMF) for interim storage. Filters and ion exchange columns are used to maintain optical clarity and remove radionuclides from the irradiated fuel bays while heat exchangers provide adequate cooling capability. Makeup water is provided from the demineralized water system.

Auxiliary irradiated fuel bay

The auxiliary irradiated fuel bay provides underwater storage for used fuel (spent fuel) from PN U1-4 and for cobalt-60 from PN U5-8. The auxiliary irradiated fuel bay is located to the southwest of the Unit 4 reactor building. A corridor connects the auxiliary irradiated fuel bay to the PN U1-4 irradiated fuel bay, and facilitates the transfer of spent fuel bundles from the PN U1-4 irradiated fuel bay to the auxiliary irradiated fuel bay after a minimum of four years of cooling following defueling. For PN U1-4, all transfers from wet to dry fuel storage in DSCs occur from the auxiliary irradiated fuel bay. For PN U5-8, all fuel is transferred directly from the PN U5-8 irradiated fuel bay to DSCs.

Turbine Hall and Turbine Auxiliary Bay

Each turbine hall and turbine auxiliary bay is located north of the reactor auxiliary bays and house the conventional equipment including the steam turbines, electricity generators, steam condensers, feedwater systems and much of the electrical distribution system. Each unit has a turbine/generator set with auxiliary systems. Pipes transport steam from the boilers to the turbine and have steam reject valves. The reject valves discharge steam to the atmosphere when the turbine is unavailable to accept steam.

Service Wing

The Service Wing is located in the centre of the station, between PN U1-4 and U5-8 and houses facilities common to all units. The Service Wing includes office space, change rooms, chemistry laboratories, maintenance workshops, warehouse storage space, decontamination facilities, as well as solid active waste management facilities and radioactive liquid waste management facilities.

Standby and emergency power and water systems

Standby power is available from independent gas turbine generators, located inside the protected area, in the event there is a loss of electrical power from the Ontario electrical grid and from a reactor unit. One set of six generators supplies PN U1-4 and another set of six generators supplies U5-8. The standby generators run on No. 2 fuel oil (i.e., distillate oil) that is stored just south of the generators. The fuel oil is stored within dyked areas that would contain the oil in the event of spillage or tank rupture.

Also located inside the protected area is the emergency water and power system building, located at the east end of the forebay. The emergency power system and emergency water systems contain all the necessary equipment to supply back-up power and water, respectively, following an earthquake or other emergency, including two standby generators, two oil tanks as well as water inlets and pumps.

Containment structures and pressure relief duct

The containment envelope includes the reactor buildings, the vacuum building structure, as well as the pressure relief duct (an elevated concrete structure running the length of the powerhouse which connects the reactor buildings to the vacuum building. The negative pressure containment system is an important safety feature that ensures containment of radioactive emissions if an accident scenario were to occur. The containment system is maintained at less than atmospheric pressure to ensure the flow of air is maintained into the system, thereby avoiding any release to the environment.

East Annex building

Located to the east of PN U5-8, this building is a two story steel frame building used for the storage of new fuel, service equipment, and tooling.

West Annex building

Located to the west of PN U1-4, this building is a two story steel frame building originally constructed to support a large scale fuel channel replacement program for PN U1-4. This building supports fuel channel inspection, environmental qualifications and lay-up support personnel.

Electrical transmission facilities

Each unit generator has one main output transformer which steps up the voltage from the generator to the level required to deliver it to the bulk electrical power system via the switchyard. The switchyard and transmission lines are owned and maintained by Hydro One Inc. In addition to the main output transformer, each unit also has two step-down transformers housed in the same building. The station service transformer allows electricity to be drawn directly from the grid and the generating service transformer allows generated power to be directed back to the station to meet internal needs. During normal operation, the load of the electrical distribution system is divided equally between the generating service transformer and the system service transformer.

Sediment suction system pumphouse

The sediment suction system pumphouse serves to limit the accumulation of sediment in plant systems. Large pumps from within this pumphouse move the sediment laden water to the PN U5-8 outfall. This sediment laden water mixes with the CCW prior to discharge to the lake.

Oil and chemical storage building

The oil and chemical storage building provides storage and dispensing facilities for bulk oils and combustible, toxic, corrosive, and reactive chemicals. The building is located between the PN U5-8 powerhouse and the switchyard.

Standby boiler

An auxiliary steam boiler is housed in an enclosure just south of Unit 8. The purpose of the boiler is to provide a backup supply of heating steam for the PN site. The boiler is fueled with fuel oil which is stored in a tank outside of the enclosure.

Administration, Engineering Services, and Security buildings

The administration building (located inside the protected area) and engineering services buildings (located outside the protected area) provide office space and support services for station staff.

There are two security buildings located on the perimeter security fence which monitor and control access to the protected area. The Main Security Building, located to the north of the administration building, serves as the primary access point for personnel to the protected area, while the Auxiliary Security Building, located at the east end of the site, serves as an alternate entry point for personnel and also allows access for vehicular traffic for the site.

Screenhouses, forebay, intake channel, intake and discharge ducts

The screenhouses and intake ducts draw condenser cooling water (CCW) and service water from the forebay for the PN units. A pair of rock groynes extends out into the lake to reduce recirculation of effluent water and silting. The screenhouse consists of screens to remove algae, fish, and other debris from the water. After the water is used in the condensers the CCW is discharged into covered ducts north of the powerhouse and returned to the lake via the discharge channel. Two CCW pumps per reactor pump water to the condensers.

High pressure emergency coolant injection facilities

The high pressure emergency coolant injection system is a special safety system that consists of a 780 m³ elevated water storage tank, a pumphouse with high pressure pumps, and an auxiliary services building. The high pressure emergency coolant injection system remains poised during normal operations, ready to inject light water into the heat transport system should an accident occur that requires additional cooling of the fuel. These facilities can serve all units in a loss of coolant situation.

New Water Treatment Plant (NWTP)

The NWTP was commissioned in 2001. The NWTP has replaced the Old Water Treatment Plant which has been decommissioned. The NWTP demineralizes lake water prior to use in feedwater and other water systems requiring demineralized water at PN. The NWTP uses filters, ultra-violet sterilization, reverse osmosis, and ion-exchange columns with a design flow rate of 66 L/s. The NWTP is located north of the PN U5-8 CCW discharge and outfall, outside the Security Protected Area, and is operated under a commercial supply contract.

Heavy water upgrading plant and towers

The heavy water upgrading plant and towers upgrade heavy water from the moderator and heat transport systems. There are two separate upgrading facilities on the PN site that serve all units. The Sulzer towers, located south of Service Wing, upgrade the moderator water (number 85 and 86 on Figure 2.2). The Upgrading Plant Pickering (UPP), located northwest of Unit 4, upgrades heat transport water. In addition to the upgrading towers, the UPP facility also houses a number of heavy water storage tanks. The UPP is partially operational - Heavy Water Upgrading towers 14B (on Figure 2.2) are no longer operational, while towers and buildings 14A, C, and D (on Figure 2.2) remain operational.

Pickering Nuclear Information Centre

The Pickering Nuclear Information Centre provides information exhibits relating to electricity generation and use with a focus on nuclear power and the environment. It is located outside of the security fence.

East Complex

The East Complex is an area consisting of several different types of operations. Included in the East Complex are technical and field support offices, warehousing, maintenance garages, machine shops, a chemical storage building, parking areas, material storage, the Auxiliary Power System, access roads, and drainage ditches. At the east end of the East Complex is the Southeast Inert Fill Area and a wetland. The Auxiliary Power System is an emergency standby power source, located in the East Complex, consisting of combustion turbine units and associated equipment (transformers, auxiliary equipment, fuel oil tanks, etc.). The system supplies electrical power to the PN site in the event of a loss of power supply from the Ontario electrical grid. The combustion-turbine standby power system uses fuel oil that is stored on-site in storage tanks within dyked areas to contain oil in case of spillage or tank rupture.

Pickering Waste Management Facility (PWMF)

The PWMF is composed of two sites, PWMF Phase I and PWMF Phase II, as shown on Figure 2.3.

PWMF I is located within the PN Generating Station protected area and is used for dry storage of used nuclear fuel and consists of a Dry Storage Container (DSC) processing building, two storage buildings to store DSCs (Storage Building # 1 and #2), and an area for the Dry Storage Modules (DSMs). The PWMF II consists of an area 500 m north-east of the site in the East Complex, within a distinct facility fenceline. PWMF II consists of a security kiosk, Storage Building # 3, and is being expanded to include Storage Building # 4. PWMF II has an EA approved area for future expansion to include a DSC Processing Building, and Storage Buildings #5 and # 6, under a separate project.

The storage buildings at both PWMF I and PWMF II are designed to store DSCs which contain nuclear used fuel from PN U1-4 and PN U5-8. The DSMs, which are large cylindrical casks made of reinforced concrete and thick carbon steel inner and outer liners, store the used reactor components removed during the retubing of the PNGS A reactors in the 1980s.

East Landfill

The East Landfill is an on-site waste disposal site established in 1971 to receive excavation and construction waste during the construction of PN U5-8. The landfill is located at the south-east corner of the intersection of Brock Road and Montgomery Park Road within PN's property boundary. A smaller area containing small mounds of inert fill and a wetland is located south-east of the main landfill. This 12-hectare landfill site was closed in 1988 and the East Landfill Perpetual Care Program was subsequently established in 1996 to monitor the surface water runoff quality from the East Landfill and the inert mounds of fill southeast of the main landfill (OPG, 2013c).

Fish Diversion System

In 2008 the Canadian Nuclear Safety Commission (CNSC) issued a directive to PN to reduce fish impingement by 80% and entrainment by 60%. A fish diversion system (FDS) consisting of a barrier net surrounding the intake structure of PN was installed in 2009, as shown in Figure 2.4. The FDS is seasonally installed for 8 to 9 months of the year during the period most fish would be typically impinged or entrained at the station.

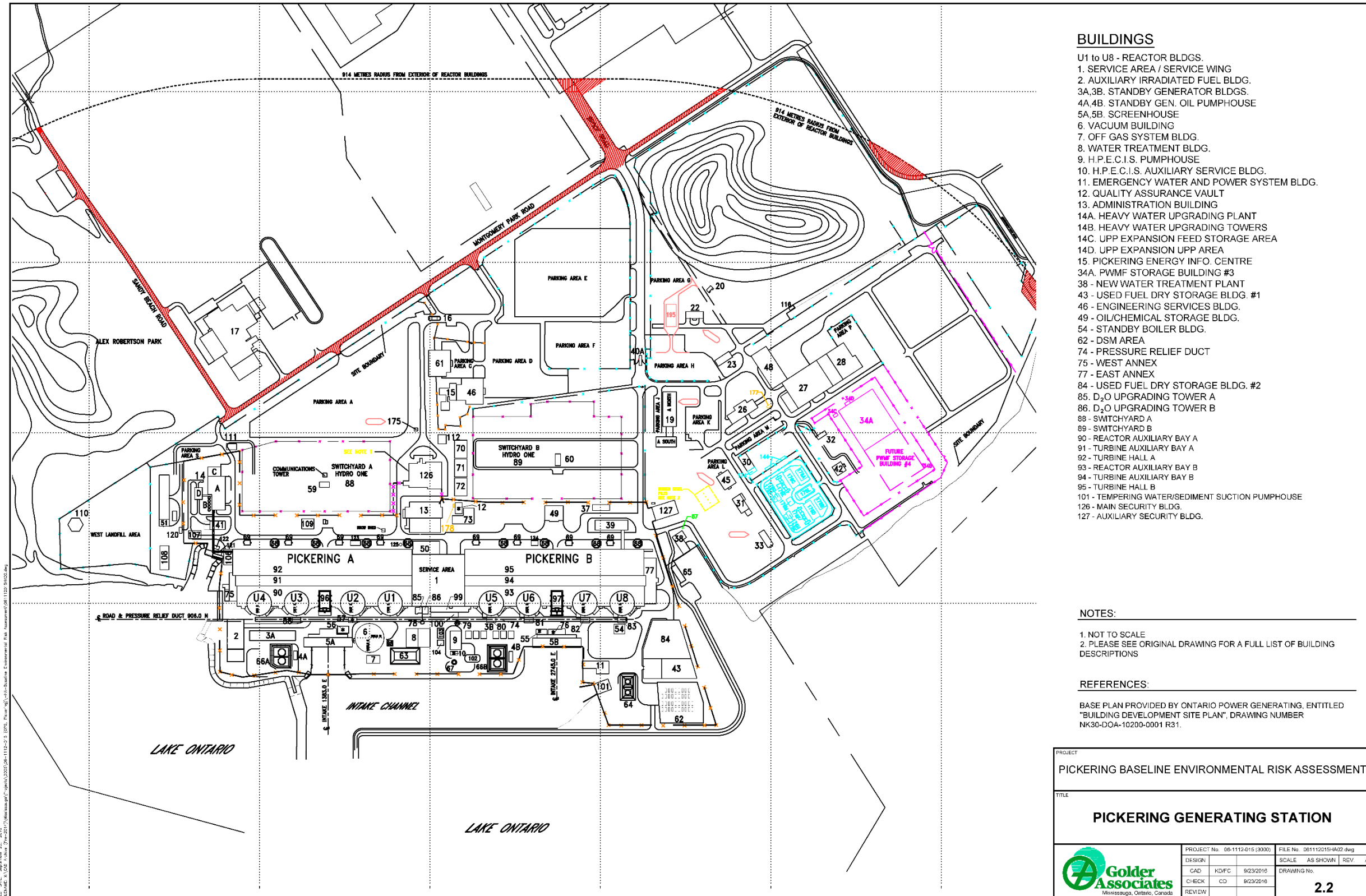

Figure 2.2: Pickering Nuclear Generating Station

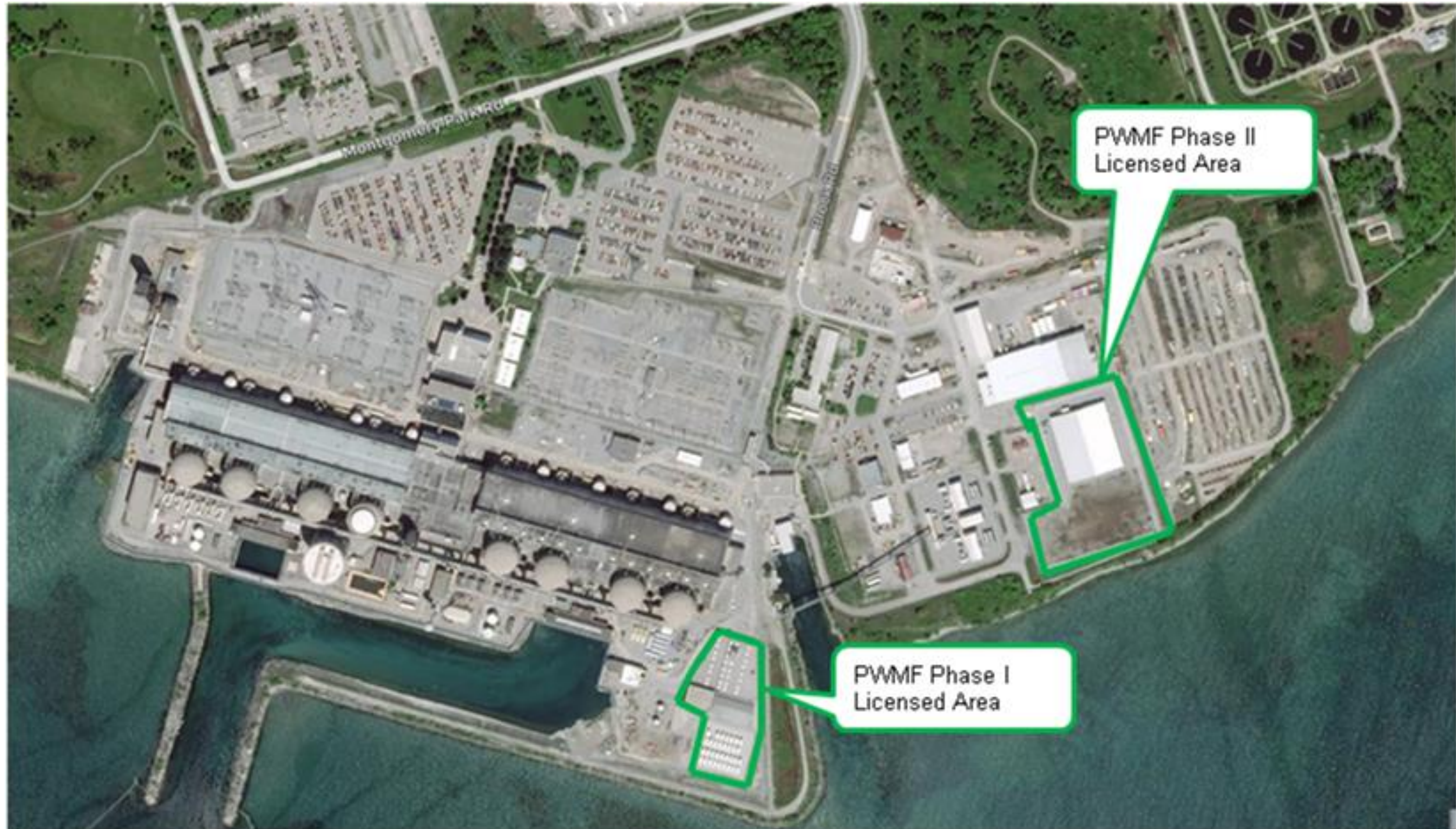

Figure 2.3: Pickering Waste Management Facility Layout and Surrounding Buildings



Figure 2.4: Photo of Installed Fish Diversion System from the East Side Looking West (OPG, 2012h)

2.2.1.1 Site Drainage and Waterborne Discharges

The site water balance is presented in Figure 2.5 (modified from Golder, 2007a). The water balance includes a number of the water systems across the PN site including the inactive drainage system, active drainage system, domestic sewage system, stormwater system, service water, the condenser cooling water systems, and the PWWF drainage system.

Inactive drainage system

The inactive drainage system consists of a network of drains (including floor, equipment, roof and foundation drains), as well as sumps, pumps and piping which collect normally inactive liquid waste from conventional systems across the site. The main sources of inactive drainage are from floor and utility drains from the turbine hall and turbine auxiliary bay (including the foundation drains) which are collected in the inactive drainage sumps located in the basement of the turbine auxiliary bay. There are eight inactive drainage sumps in total, one associated with each unit. The inactive drainage sumps are pumped to a common inactive drainage header which is sampled as it passes through the old water treatment plant and eventually enters the yard drainage system which discharges into the forebay. In the summer months (typically June to November) when the chlorination system is in-service, the inactive drainage header is injected with sodium metabisulphite while passing through the old water treatment building. It is diverted to the settling basin prior to discharge into the forebay to facilitate de-chlorination.

Some inactive drainage streams such as overflow spray water from the ventilation system discharge directly to the CCW discharge duct.

Active drainage system

The active drainage system also consists of a series of floor and equipment drains, as well as sumps, pumps and piping, which collects normally active liquid waste, segregated according to the degree of radioactivity and chemical composition, and directs the waste to the receiving tanks of the radioactive liquid waste management system (RLWMS). Sources of the active liquid waste include reactor building floor drains, reactor auxiliary bay floor drains, irradiated fuel bay drainage, and spent ion exchange resin slurring water. The RLWMS includes filters and ion exchange columns to purify the waste. After treatment the waste is sampled and chemically analyzed to ensure it meets radioactive and chemical limits prior to discharge. Radioactivity monitors on the discharge piping automatically stop discharge flow if the detected activity is above prescribed limits.

Service Water and Condenser Cooling Water Systems

There is a common intake for both PN U1-4 and U5-8, called the forebay. From the forebay, water is directed through either screenhouse (located at either end of the forebay) to the PN U1-4 or U5-8 intake channel which spans the length of all four units. Cooling water is pumped into each unit from the intake channel via the condenser cooling water

(CCW) and service water pumps. Service water is then discharged to the outfalls via the reactor building service water return (located to the south of the reactor buildings) while the CCW flows are discharged to the outfalls via the CCW discharge duct located to the north of the powerhouse. With all six units operating, total inflows/outflows for the station range on average from 190 to 220 m³/s. CCW flows make up the largest proportion of the station inflows/outflows with a combined flow of approximately 170 m³/s (50 m³/s on the PN U1-4 side and 120 m³/s on the U5-8 side).

Domestic Sewage system

Domestic sewage is collected throughout PN and is discharged into the Regional Municipality of Durham sewage mains. Sewage waste is sampled and analyzed on a regular basis for radioactivity (tritium and gross beta).

Station stormwater drainage

Stormwater is discharged directly to Lake Ontario at different locations. The switchyard drainage system directs stormwater to catchment basins and discharges it via the CCW outfall to Lake Ontario. Measures such as good housekeeping, drain covers in areas of potential oil contamination and use of swales and ditches all contribute to minimizing contamination of stormwater.

PWMF drainage

Surface drainage from the PWMF Phase I site is directed through the PN drainage network into the PN U5-8 discharge channel. Drainage from the Retube Component Storage area is also directed via catch basins to the PN U5-8 discharge channel.

Surface drainage from the PWMF Phase II site in the East Complex area drains to Lake Ontario via the stormwater system.

Active drainage generated from PWMF activities (mainly washing workshop floor) is collected and stored in one of two above ground storage tanks) located in the Phase I workshop. The contents of the tanks are transferred periodically to the RLWMS for processing.

Other discharges

Other, relatively minor sources of water discharge include periodic boiler blowdown (discharged to the intake channel), UPP discharge to the Unit 1-4 discharge channel, and the new water treatment plant discarding backwash water to the Unit 5-8 discharge channel.

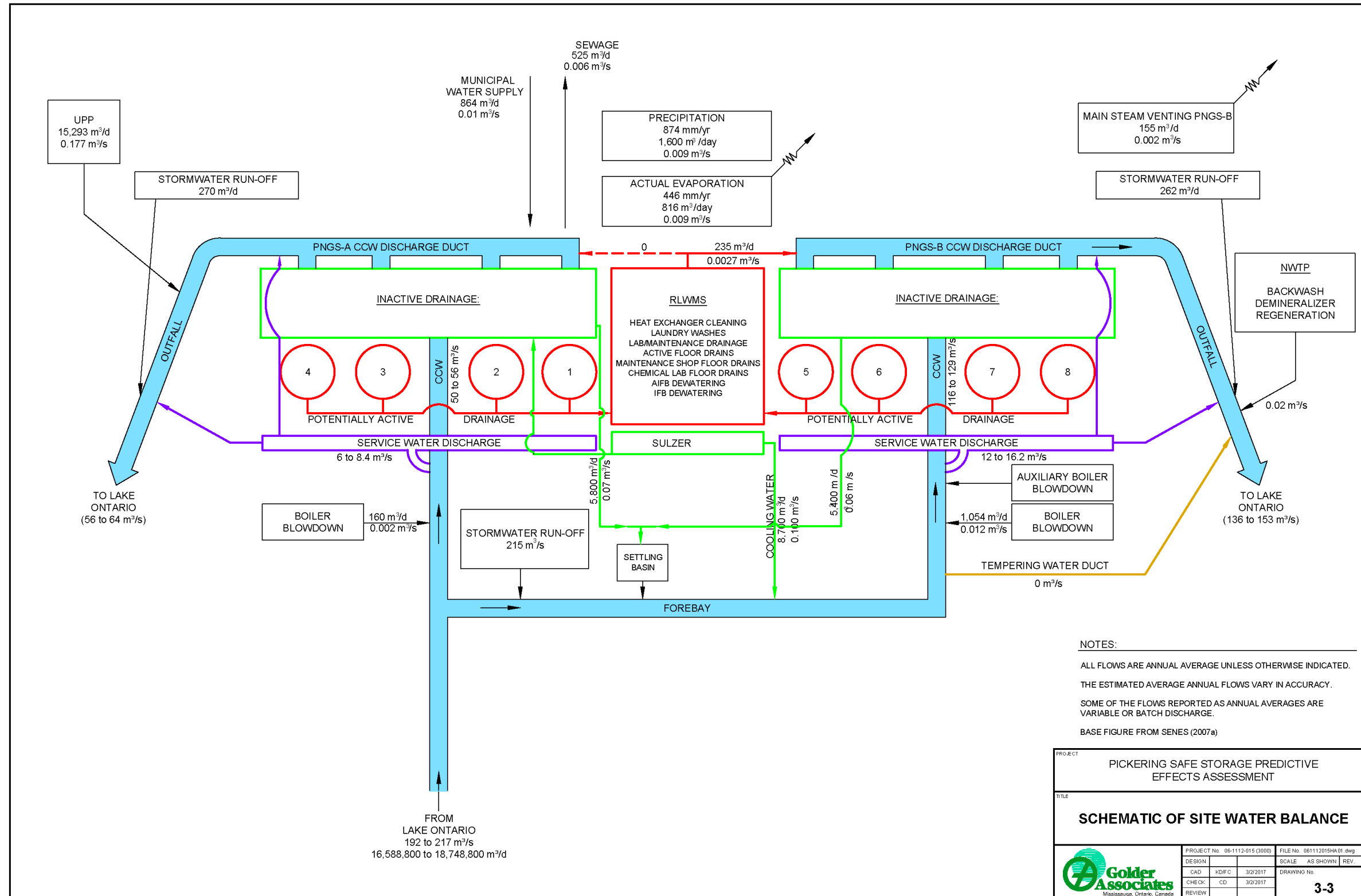

Figure 2.5: Pickering Nuclear Site Water Balance (modified from Golder, 2007a)

2.2.1.2 Heating and Ventilation

The heating systems are designed to provide comfort to individuals working in the plant and to maintain equipment. Ventilation and air conditioning systems control temperature, moisture, and atmospheric conditions as required for employees and plant equipment. Exhaust from areas that may contain radioactive materials are filtered and monitored prior to discharge.

The current powerhouse heating system supplies downgraded steam diverted from the steam turbine extraction to the extraction steam header which runs the length of the powerhouse. This header provides steam for building heating to powerhouse structures including the reactor auxiliary bays, turbine auxiliary bay, turbine halls, Service Wing, Administration Building, East and West Annexes and heavy water upgrading buildings.

Commercial electric heaters and/or HVAC units provide additional heating and ventilation for buildings outside of the powerhouse, including the PWMF, screenhouses, and the security buildings. Hot water from the domestic water system is used for humidification.

2.2.2 Materials Management

The PN site has a multitude of systems that are designed to manage both radioactive and non-radioactive materials. The main radioactive material managed at the PN site is heavy water.

The heavy water management system is used to store, transfer and recover heavy water for use in the heat transport system and moderator systems. The system is made up of D₂O storage tanks and collection tanks as well as pumps and piping systems to facilitate transfer between systems and units. Heavy water leakage is collected in the liquid and vapour forms and recovered for reuse.

Additional heavy water management systems include D₂O clean-up and upgrading. Clean-up processes remove impurities from heavy water using ion exchange, filtration, and oil/water separation, while the upgrading process uses distillation to separate light water from the heavy water.

A brief summary of the use(s) and the associated management methods for chemicals used across the site are presented in Table 2.3.

Table 2.3: Chemical Usage and Disposal

Chemical	Use	Disposal
Boric acid	Reactivity control in the moderator system	Removed by ion exchange in the moderator purification system. For disposal, see Ion exchange resins, below.
Gadolinium nitrate	Reactivity control in the moderator system	Removed by ion exchange in the moderator purification system. For disposal, see Ion exchange resins, below.
Helium gas	A cover gas preventing the ingress of air for the moderator, liquid zone controllers, and the heavy water storage tank.	Periodically purged to reactor building exhaust
Oxygen gas	Added to combine with deuterium gas to maintain pressure	Consumed and emitted with building exhaust
Hydrogen gas	Added to remove oxygen gas from the heat transport system (HTS) and to cool generators	Consumed in the HTS and vented to the reactor building exhaust. Vented to the atmosphere from the main generators
Hydrazine	Removes oxygen and used for pH control in the emergency coolant injection system, boiler feedwater, condensate feedwater, recirculating cooling water system, and end shield cooling water.	Consumed, but residual may be discharged to the atmosphere or to the lake.
Lithium hydroxide	Controls pH in the HTS, end shield cooling system, and the recirculating cooling water system.	Consumed when pH is corrected.
Ion exchange resins	Used for pH control and removal of impurities in the moderator system, irradiated fuel bay, auxiliary fuel bay, liquid zone control, heat transport system, end shield cooling system, and the recirculating cooling water system.	The resin is temporarily held within spent resin tanks and is placed in interim storage at the Western Waste Management Facility (WWMF) at the Bruce site.
Ion exchange resins (Sulphite)	Removes oxygen gas in the stator cooling water system.	Disposed as waste by licensed contractors based on analysis.
Sulphuric acid	Used in production of demineralized water.	Consumed during usage.

Chemical	Use	Disposal
Sodium metabisulphite	Used in production of demineralized water and to de-chlorinate effluent.	Consumed during usage.
Anti-scalant	Used in production of demineralized water.	Consumed during usage.
Sodium hypochlorite	Used in production of demineralized water and zebra mussel control in the low pressure service water.	Consumed during usage in demineralized water production. When applied for zebra mussel control, it is consumed and the residual is discharged to Lake Ontario.
Sodium hydroxide	Used in production of demineralized water.	Consumed during usage.
Carbon dioxide gas	Used in the annulus gas system as a carrier gas and in the generators as a purging gas	Vented from the annulus gas system to the reactor building exhaust and vented to the atmosphere from the generators.
Morpholine	pH and corrosion control in the boiler feedwater and in the condensate feedwater	Partly consumed in its usage and the balance is lost to atmospheric discharge and boiler blowdown
Sulphur hexafluoride	Leak detection in the CCW system.	Released to Lake Ontario in small volumes
Distillate oil (fuel/diesel)	Fuel in the standby generator, emergency power generators, and the auxiliary power system.	Consumed and results in waste gases including CO ₂ , NO _x , SO ₂ , etc.
Lubricating oil and seal oil	Lubrication and sealing of the turbine system and the generator system	Reused and removed by licensed contractor.
Insulating oil	Transformer cooling in the main output and service transformers.	Removed by licensed contractor.
Ethylene glycol	Air conditioners in the battery rooms.	Ethylene glycol is removed by licensed contractors.
Reolube Turbo fluid 46	Hydraulic fluid for turbine governor valves in the turbine governors.	Reused or placed into drums for disposal by licensed contractors.

2.2.2.1 Waste Management

Waste produced on-site includes used fuel, radioactive solid waste, radioactive liquid waste, radioactive gaseous waste, and non-radioactive solid, liquid, and gaseous waste.

2.2.2.1.1 Used Fuel

Used fuel bundles are initially stored in the irradiated fuel bays for at least 10 years and then transferred to DSCs for interim storage in the PWWF. In the irradiated fuel bay, used fuel bundles are placed into 96-bundle storage modules. Modules with used fuel at least 10 years or older may be loaded into a DSC, which has the capacity to hold four storage modules. The DSC is loaded with the storage modules and the lid is secured while the DSC is submerged in water. The DSC is then removed from the water, drained, the exterior decontaminated, and then the DSC is prepared for on-site transfer to the PWWF for further processing and subsequent interim storage (OPG, 2013a).

2.2.2.1.2 Radioactive Solid Waste

Radioactive Solid Wastes include both intermediate and low level wastes. Low Level Waste (LLW) is defined as waste with contact radiation fields of less than 10 mSv/h at 30 cm. LLW is made of maintenance wastes from day-to-day reactor operations including cleaning materials, personal protective equipment, contaminated metal parts, metal sweepings, and miscellaneous items. LLWs are categorized as incinerable, compactable, or as non-processible.

The majority of incinerable LLW is collected in plastic bags, packed into shipping containers and transportation packages, and shipped off-site for incineration at the WWMF at the Bruce site. LLW may be briefly stored in the Solid Waste Handling Facility located in the Service Wing prior to shipping off-site.

Compactable LLW, including light gauge metals, welding rods, metal cans, insulation, metallic air filters, air hoses, small cables, and other assorted wastes, is collected in plastic bags and temporarily stored in the solid radioactive waste handling area before being shipped to the WWMF where it is compacted and stored.

Non-processible LLW includes lathe turnings and metal filings, heavy gauge metal and components, floor sweepings, glass, and larger electrical cables. This waste is packaged and shipped to the WWMF.

Intermediate Level Waste (ILW) is defined as waste with dose rates greater than 10 mSv/h at 30 cm. Materials categorized as ILW include spent ion exchange resins, disposable filters, and other non-processible radioactive wastes.

The spent ion exchange resins are slurried from the purification systems to spent resin storage tanks. Spent resin is then slurried periodically from the holding tanks to a storage (stainless steel) liner and transported in bulk de-watered form to the WWMF on the Bruce site. Low level resin/charcoal generated from the RLWMS is transferred into totes and sent to WWMF as well.

After their removal, radioactive disposable filters are placed within shielding flasks and are transferred to the in-station flask lay-down area in the PN U1-4 Turbine Loading Bay, where they are then placed within the Radioactive Filter Transportation Package and shipped to the off-site WWMF for storage.

Non-processible radioactive waste that is classified as ILW is packed in appropriate sized containers in the solid radioactive waste management area for shipment to the WWMF.

2.2.2.1.3 Radioactive Liquid Waste Management System

The RLWMS receives, treats and disposes of all potentially active liquid waste streams not containing appreciable amounts of heavy water directed to the system via the active drainage system. The activity in the liquid waste originates from contamination by mixed fission products, process system corrosion and activation products, and may include tritium, carbon-14, gross alpha and gross beta-gamma. Gross beta-gamma is a gross measure of radioactivity and is inclusive of all non-volatile radionuclides in effluent including cesium-137, cesium-134, strontium-90, cobalt-60, etc.

Active liquid waste from the PWWF is pumped to the RLWMS for processing. A simplified flow diagram of the RLWMS is shown in Figure 2.6.

Active or potentially radioactive liquid wastes with chemical contaminants are directed through a purification system, as required, in order to reduce radioactive and non-radioactive impurities. Following treatment and confirmation of sample results, the waste is then directed to dedicated clean tanks where it awaits discharge. The effluent is sampled for radiological and chemical parameters prior to release and is discharged only if required specifications are met. In addition to meeting all active and non-radioactive limits, all discharges from the RLWMS must be non-toxic as directed by the Provincial Municipal Industrial Strategy for Abatement (MISA) regulations. Radioactivity monitors on the discharge piping automatically stop discharge flow if the detected activity is above specified limits. Treated wastes are discharged to Lake Ontario through the CCW discharge ducts and the PN U1-4 and U5-8 outfall structures.

Select types of non-aqueous radioactive liquids including lubricating oils and liquid scintillation cocktails are transported to the WWMF for incineration. Other non-aqueous radioactive liquids are solidified and sent to the WWMF as non-processible drummed waste. Low activity chemical wastes are collected and shipped to licensed third party facilities for treatment. Where it is necessary, secondary wastes from third party treatment, including incinerator ash, are returned to OPG for storage at the WWMF.

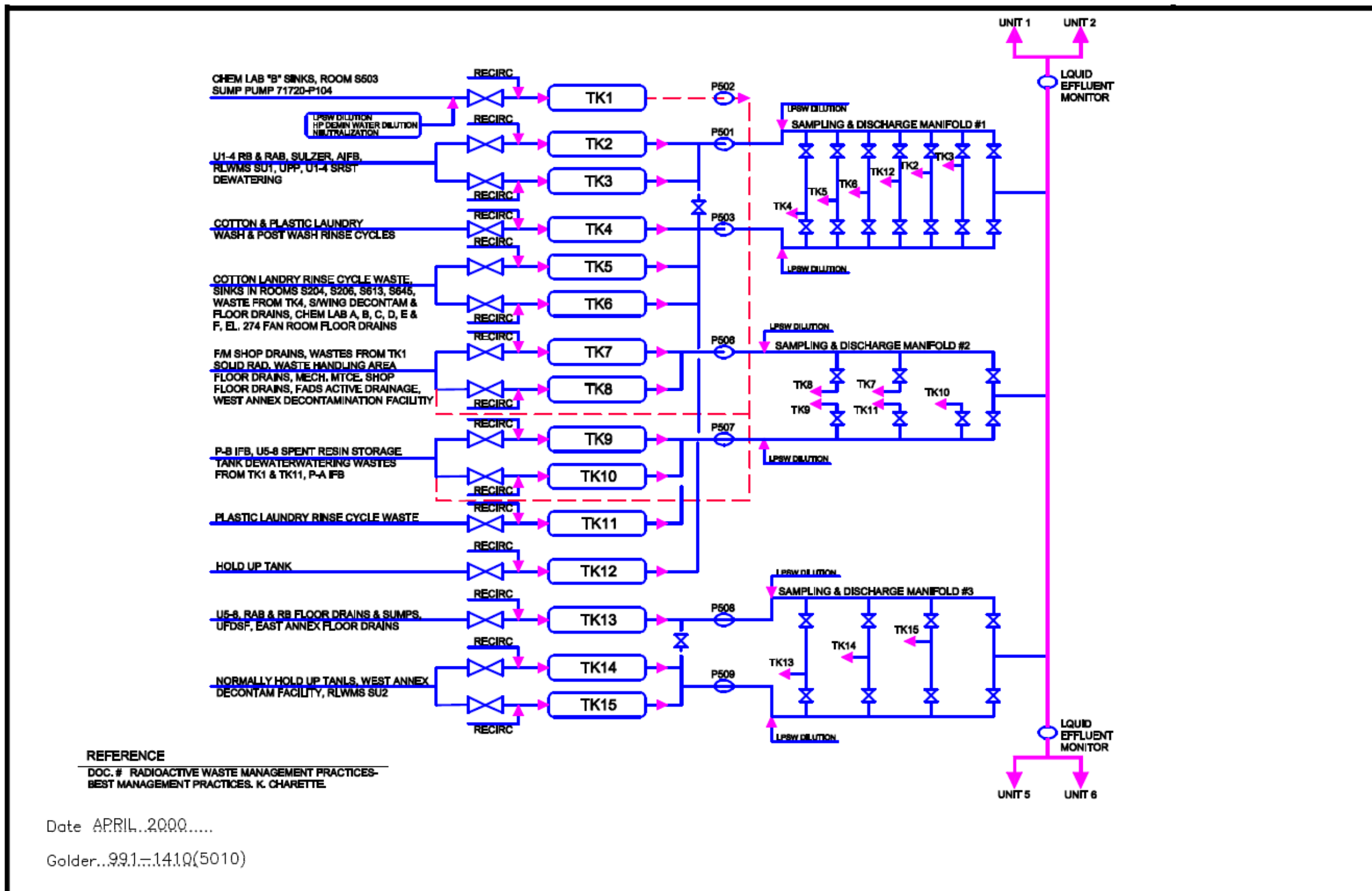

Figure 2.6: Simplified Radioactive Liquid Waste Management System Flow Diagram (OPG, 2000a)

2.2.2.1.4 Radioactive Gaseous Emissions

Sources of airborne radioactive emissions include the air exhaust from the reactor buildings, the irradiated fuel bays, the upgraders (Sulzer and UPP), the East and West Annexes, various systems/areas within the Service Wing, and the used fuel dry storage facility (PWMF).

Tritium is released from the heavy water system to the reactor building in the form of tritiated water vapour. Tritium can also be released into the reactor building atmosphere through steam generator tube or heat transport system leaks. Dryers in the recirculating ventilation systems are used to remove airborne tritium by recovering the heavy water vapour.

Gaseous wastes from potentially active areas are monitored for radioactivity before atmospheric release. When radioactive particulates and radioiodine may be present, gases from active ventilation stacks are filtered through absolute and charcoal filters prior to release.

The primary source of particulate emissions is the heat transport system where solid radionuclides originate from within the fuel bundles or from corrosion of system components. Additional radioactive particulate emissions include cesium-137 and cobalt-60 which primarily originate from the heat transport system where they are formed in the fuel bundles or from corrosion of the system components. Carbon-14 is released from the moderator cover gas system and the annulus gas system through the reactor building stack. The ventilation exhaust stacks are monitored for particulate and gaseous carbon-14 activity where necessary.

Argon-41, a noble gas, can be released in the reactor building ventilation due to leaks and purges from the annulus gas system, moderator cover gas system, the helium sub-system of the liquid zone control system, and the calandria vault air. Xenon-133 can be released when there are minor defects in the Zircaloy-4 cladding of the fuel tubes. The radioactive noble gases cannot be effectively filtered but strict quality control in fuel elements results in low noble gas emissions. Radioactive iodine isotopes are formed by fission and can escape through defects in fuel bundles. Monitors to detect noble gas and iodine are in place where appropriate.

Radioactive gaseous emissions are modelled, for the purpose of public dose calculations, as two virtual sources: one from PN U1-4 and one from U5-8.

2.2.2.1.5 Non-Radioactive Solid Waste

Non-radioactive wastes are re-used or recycled where feasible. Hazardous wastes are handled in accordance with regulations and are shipped off site to licensed disposal facilities. Non-hazardous solid wastes are disposed in an off-site landfill if landfill requirements are satisfied.

2.2.2.1.6 Non-Radioactive Liquid Waste

Aqueous liquid effluent, except for domestic sewage and some stormwater drainage, from PN is discharged into the CCW discharge duct, the outfall structures or the forebay. The majority of stormwater drainage is directed to Lake Ontario, and domestic sewage is directed to the York-Durham Water Pollution Control Plant.

Non-radioactive liquid emissions are controlled in accordance with the provincial Environmental Compliance Approval (ECA) requirements (formerly Certificate of Approval), and with the MISA program under O. Reg. 215/95 (Effluent Monitoring and Effluent Limits – Electric Power Generation Sector).

Under O. Reg 215/95 PN monitors the control points in use for MISA Compliance monitoring. Monitored parameters at the control points include: aluminum, iron, pH, acute lethality/toxicity, chronic lethality/toxicity, phosphorus, oil and grease, total suspended solids, and zinc. The control points and the parameters monitored at each point are presented in Table 2.4 (OPG, 2015d). Two control points (i.e., CP 1000 Equipment Cleaning Effluent – A, and CP 3800 – Equipment Cleaning Effluent – B), have never been established and have never had discharges.

The locations and parameters monitored for ECA compliance are presented in Table 2.5 (OPG, 2016e).

Table 2.4: MISA Monitoring Requirements

Control Point	MISA Monitoring Requirements ²	Monitoring Frequency	Daily Limit (mg/L)	Monthly Limit (mg/L)
Radioactive Liquid Waste Management System – A (CP 200) Radioactive Liquid Waste Management System – B (CP 3700)	Phosphorus	Weekly	-	1.0
	Total Suspended Solids	Daily	73.0	21.0
	Zinc	Weekly	1.0	0.5
	Iron	Weekly	9.0	3.0
	Oil and Grease	Weekly	36.0	13.0
	pH	Daily	6.0-9.5	-
	Acute Lethality/Toxicity	Quarterly	-	Non-toxic
	Chronic Lethality/Toxicity	Semi-Annually	-	Non-toxic
Water Treatment Plant Neutralizing Sump ¹ (CP 3100) “New” Water Treatment Plant discharge (CP 4400)	Total Suspended Solids	Daily	70.0	25.0
	Aluminum	Weekly	13.0	4.5
	Iron	Weekly	2.50	1.0
	pH	4 hours	6.0-9.5	-
	Acute Lethality/Toxicity	Quarterly	-	Non-toxic
	Chronic Lethality/Toxicity	Semi-Annually	-	Non-toxic
Oily Water Separator – A ¹ (CP 3600)	pH	Daily	6.0-9.5	
	Oil and Grease	Daily	15.0	
Unit 1 Building Effluent ¹ (CP 300) Unit 2 Building Effluent ¹ (CP 400) Unit 3 Building Effluent ¹ (CP 500) Unit 4 Building Effluent ¹ (CP 600) Unit 5 Building Effluent ¹ (CP 700) Unit 6 Building Effluent ¹ (CP 800) Unit 7 Building Effluent ¹ (CP 900) Unit 8 Building Effluent ¹ (CP 100) Unit 1-8 Combined Building Effluent (CP 4600)	Total Suspended Solids	Quarterly	-	-
	Oil and Grease	Quarterly	-	-
	Acute Lethality/Toxicity	Quarterly	-	Non-toxic

Note:
¹ denotes an inactive system

² Table 2.4 is provided for reference purposes only. Current MISA monitoring requirements should always be verified against O.Reg 215/95.

Table 2.5: ECA Monitoring Requirements

Location	ECA Monitoring Requirements	Monitoring Frequency	ECA Limit (mg/L)
Condenser Cooling Water Duct	Ammonia, unionized	Weekly	0.02
	Hydrazine	Weekly	0.1
	Morpholine	Weekly	0.02
	Total Residual Chlorine	Continuous	0.01
	pH	Weekly	6.0-9.5
Reactor Building Service Water	Ammonia, unionized	Daily	0.2
	Hydrazine	Daily	1.0
	Morpholine	Daily	0.2
	pH	Daily	6.0-9.5
	Dissolved Oxygen	Weekly	≥4.0
	Total Residual Chlorine	Continuous	0.5
Boiler Blowdown	Total Ammonia	Monthly	5
	Hydrazine	Monthly	1
	Morpholine	Monthly	50
	pH	Monthly	-
Inactive Drainage Sumps	Oil and Grease	Quarterly	15
	Total Suspended Solids	Quarterly	25
	Total Residual Chlorine	Chlorination Season	0.04
Oil/Water Separator	Oil and Grease	Quarterly	15
Heavy Water Upgrader Plant	Total Ammonia	Semi-annually	0.02
	Hydrazine	Semi-annually	0.1
	Morpholine	Semi-annually	0.02
	pH	Semi-annually	6.0-9.5
New Water Treatment Plant	Total Residual Chlorine	Continuous	0.1
	Total Suspended Solids	Daily	70
	Aluminum	Weekly	13
	Iron	Weekly	2.5
	pH	Continuous	6.0-9.5
	Toxicity –Acute	Monthly	Non-Toxic
	Toxicity – Chronic	Semi-Annual	Non-Toxic

Note:

Table 2.5 is provided for reference purposes only. Current ECA monitoring requirements should always be verified.

2.2.2.1.7 Non-Radioactive Gaseous Emissions

Non-radioactive gaseous emissions are controlled in accordance with provincial ECA requirements. An Emissions Summary and Dispersion Modelling (ESDM) report is used to document and maintain compliance with O.Reg. 419/05 (Air Pollution – Local Air Quality) and forms the basis for the site's former Basic Comprehensive Certificate of Approval (CofA No. 9090-6SBGEH) and current ECA (ECA No. 4766-A3YMB9).

The PN site is expected to have non-radioactive gaseous emissions including the products of fuel combustion, particulate matter, and volatiles. The ESDM lists maximum point of impingement concentrations for significant contaminants (Golder, 2011). Contaminant concentrations are determined based on the calculated emission rates and the output from the approved dispersion model in compliance with O.Reg. 419/05. The 2011 ESDM is the basis for the most current ESDM. In 2014, an updated Emergency Equipment Assessment was completed to include additional sources; however, the results do not change the maximum POI concentrations identified in the 2011 ESDM. In 2015, an additional assessment for hydrazine was completed which changed the maximum POI concentration for hydrazine from a ½ hour concentration to an annual concentration based on request from the MOECC. All other parameters remained unchanged from the 2011 ESDM (OPG, 2015e).

The locations of the air emissions sources used in the 2011 ESDM are presented in Figure 2.7. In the ESDM report the facility was modelled with six virtual air emission sources and two point sources. The facilities and contaminants associated with each virtual source and point source are presented in Table 2.6.

As identified in Figure 2.7 virtual source one (VS1) encapsulates much of the PN facility located south of the switchyards and north of the forebay while VS2 through VS6 and point sources 7 and 8 (PS7 and PS8) only contain emissions from single types of sources.

Table 2.6: Modelled Sources and Associated Contaminants

Source Identification	Operations/Facilities at Source	Expected Contaminants
Virtual Source 1 (VS1)	Standby Gas Turbines	Products of distillate oil combustion
	Auxiliary Steam Boiler	
	Side Steam Venting Systems	Water conditioning chemicals
	Service Wing	Volatile chemicals
	Fuel Storage Tanks	Fuel oil vapour
	Gas Cylinders	Argon, carbon dioxide, carbon monoxide, deuterium, helium, hydrogen, methane, nitrogen, and sulphur hexafluoride
	Mobile Small Combustion Sources	Products of gasoline and diesel combustion
	Sodium Hypochlorite Storage Tanks	Sodium hypochlorite
	Pressure Relief Ducts	Ethylene gas
	Diesel Generators	Products of diesel combustion
Diesel Powered Fire Pumps	Products of diesel combustion	
Virtual Source 2 (VS2)	Transportation and Work Equipment Garage Exhaust Extraction System	Products of gasoline and diesel combustion
Virtual Source 3 (VS3)	Carpentry Shop Baghouse	Particulate matter
Virtual Source 4 (VS4)	East Complex Garage	Volatile chemicals and products of gasoline and diesel combustion
Virtual Source 5 (VS5)	Auxiliary Diesel Generators (Auxiliary Power System)	Products of diesel combustion
Virtual Source 6 (VS6)		
Point Source 7 (PS7)	Combustion Turbine Units (Auxiliary Power System)	Products of distillate combustion
Point Source 8 (PS8)		



Figure 2.7: Non-radiological Air Emissions Sources (Golder, 2011)

2.3 Description of the Natural and Physical Environment

This section will describe the natural and physical environment according to the spatial scale defined in Section 1.2. This includes parts of the SSA, LSA, and RSA, as defined in Section 1.2.

This section will briefly describe meteorology and climate, site geology, hydrogeology, hydrology, vegetation communities, aquatic communities, human land use, and population distribution with a focus on PN site conditions. More detailed information can be obtained from the following TSDs for the Pickering B Refurbishment for Continued Operation EA with updates based on information from 2011 to 2015:

- NK30-REP-07701-00003 “Atmospheric Environment” (SENES, 2007d);
- NK30-REP-07701-00006 “Geology, Hydrogeology and Seismicity” (Golder, 2007d);
- NK30-REP-07701-00007 “Surface Water Resources” (Golder, 2007a);
- NK30-REP-07701-00008 “Aquatic Environment” (Golder, 2007b);
- NK30-REP-07701-00009 “Terrestrial Environment” (Golder, 2007c);
- NK30-REP-07701-00015 “Human Health” (SENES, 2007b); and
- NK30-REP-07701-00004 “Radiation and Radioactivity” (SENES, 2007c).

2.3.1 Meteorology and Climate

The PN site is located in southern Ontario on the north shore of Lake Ontario. It displays a humid continental climate with four distinct seasons. In Southern Ontario, the climate is highly modified by the influence of the Great Lakes which results in uniform precipitation amounts year-round, delayed spring and autumn, and moderated temperatures in winter and summer (Environment Canada, 1997). Meteorological data were collected from stations within the site, local and regional areas.

2.3.1.1 Temperature

Local temperature data are collected at the PN meteorological station at a height of 10 metres above ground level. The local temperature data from the PN meteorological station for the five year period including 2011 to 2015 are summarized as monthly mean, minimum and maximum values in Table 2.7. Figure 2.8 presents minimum, mean and maximum monthly values for the period. Winter mean monthly temperatures, December to March, are below 0°C. Summer mean monthly temperatures, June to September, are typically above 15°C. The mean annual temperature for 2011 to 2015 was 8.6°C.

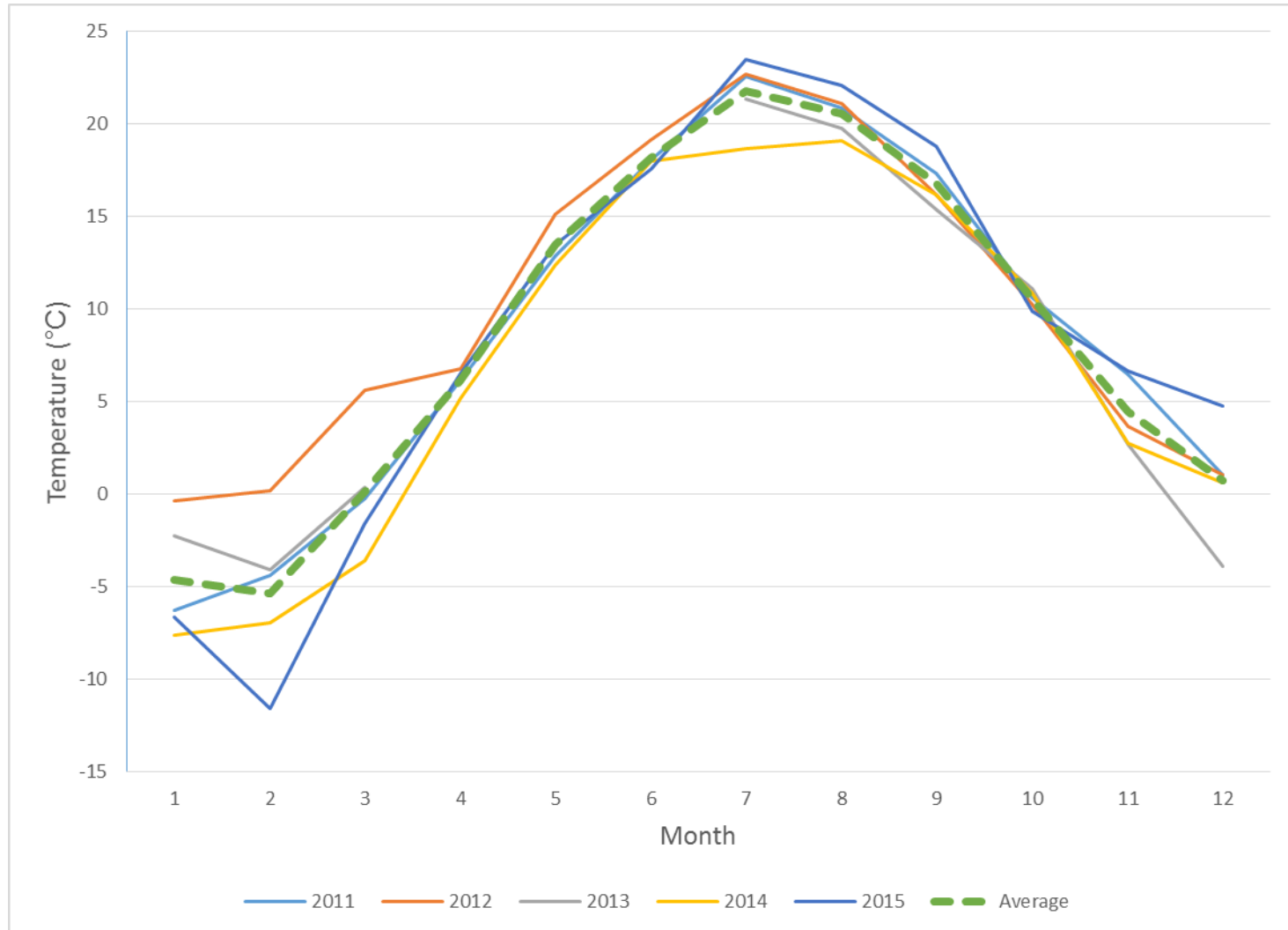

Figure 2.8: Average Monthly Temperatures Reported at the PN Meteorological Station (2011-2015)

Table 2.7 summarizes the most recent temperature data available for two regional meteorological stations near the PN site: Pearson International Airport (TOR) (1981 to 2010) and Oshawa Water Pollution Control Plant (OSH) (1981 to 2010) (Government of Canada, 2016), along with temperature data from 2011 to 2015 from the PN meteorological station (at the 10 m elevation). The meteorological data collected from the PN meteorological station are generally consistent with the regional temperature normals.

Table 2.7: Temperature Normals near Pickering Nuclear

Month	Daily Mean (°C)			Mean Daily Maximum (°C)			Mean Daily Minimum (°C)		
	TOR ¹	OSH ²	PN ³	TOR ¹	OSH ²	PN ³	TOR ¹	OSH ²	PN ³
January	-5.49	-4.76	-4.63	-1.51	-1.06	-0.35	-9.44	-8.45	-7.62
February	-4.54	-3.61	-5.38	-0.35	0.06	0.16	-8.7	-7.28	-11.61
March	0.06	0.37	0.12	4.62	4.24	5.61	-4.49	-3.51	-3.59
April	7.06	6.62	6.14	12.21	10.76	6.75	1.86	2.46	5.18
May	13.12	12.3	13.47	18.79	16.89	15.14	7.41	7.68	12.38
June	18.6	17.57	18.17	24.19	22.26	19.12	12.95	12.85	17.54
July	21.45	20.55	21.75	27.06	25.13	23.49	15.79	15.93	18.68
August	20.55	19.97	20.57	26.01	24.26	22.09	15.05	15.64	19.10
September	16.2	15.94	16.76	21.61	20.16	18.78	10.75	11.69	15.38
October	9.5	9.47	10.53	14.31	13.32	11.07	4.63	5.57	9.85
November	3.72	4.21	4.42	7.59	7.38	6.63	-0.17	1.02	2.66
December	-2.18	-1.18	0.70	1.41	2.07	4.75	-5.76	-4.43	-3.93
Year	8.17	8.12	8.55	-	-	-	-	-	-

Notes:

¹ Toronto Pearson International Airport, 1981-2010 (Government of Canada, 2016).

² Oshawa Water Pollution Control Plant, 1981-2010 (Government of Canada, 2016).

³ Pickering Nuclear, 2011 to 2015 PN Meteorological Station.

2.3.1.2 Precipitation

Local precipitation data are not available from the PN site. Precipitation data were obtained for the Oshawa Climate Station (43°52' N; 78°50' W), located approximately 19 km east of PN in Pickering for the period of 1981 to 2010. Climate normals for the Oshawa Climate Station for the period of 1981 to 2010 provide the most recent available precipitation data for the regional study area at this time (Government of Canada, 2016). Precipitation, rain and snow fall data for 1981 to 2010 are summarized in Table 2.8. The data demonstrate that precipitation is fairly consistent throughout the year with slightly more precipitation in the second half of the year. The Oshawa station reports an average total annual precipitation of approximately 871.9 mm of which less than 15% is snowfall. Total monthly precipitation averages range from approximately 54 mm in March to approximately 94 mm in September.

Total monthly precipitation normals from Oshawa are compared to the most recent precipitation normals (1981 to 2010), for the Pearson International Airport (TOR) and Toronto Buttonville Airport (BUT) climate stations (Government of Canada, 2013). The TOR is located approximately 35 km west – south – west of the PN site, and the BUT is located approximately 24 km north-west of the PN site. The data sets for these meteorological stations overlap for the period from 1981 to 2010. Table 2.8 and Figure 2.9 show that monthly precipitation within the regional study area follow similar trends.

In the past, local precipitation data were taken from the Frenchman’s Bay Climate Station, located a few kilometers west of PN in Pickering where data for the period of 1971 to 2000 were available. Based on the period of 1971 to 2000, precipitation at Frenchman’s Bay is fairly consistent throughout the year with slightly more precipitation in the second half of the year. The Frenchman’s Bay station reported an average annual precipitation of approximately 879 mm of which less than 15% is snowfall. Monthly precipitation averages range from approximately 49 mm in February to approximately 84 mm in September.

Table 2.8: Precipitation from the Oshawa Climate Station (1981 – 2010) (Government of Canada, 2016)

Month	Monthly Averages			Daily Extremes		
	Precipitation (mm)	Rain (mm)	Snow (cm)	Precipitation (mm)	Rain (mm)	Snow (cm)
January	65.6	30.0	35.6	42.6	42.6	27.9
February	56.6	31.7	24.9	42.8	42.8	27.0
March	54.2	40.7	13.5	32.8	32.8	18.4
April	72.7	70.6	2.0	47.6	47.6	20.3
May	78.9	78.9	0	41.6	41.6	0
June	73.9	73.9	0	144.8	144.8	0
July	73.1	73.1	0	70.4	70.4	0
August	77.4	77.4	0	75.4	75.4	0
September	94.0	94.0	0	80.8	80.8	0
October	70.1	70.0	0.1	45.6	45.6	6.6
November	84.8	80.0	4.7	59.0	59.0	17.8
December	70.7	45.8	24.9	39.1	35.6	29
Annual Total	871.9	766.1	105.8	-	-	-

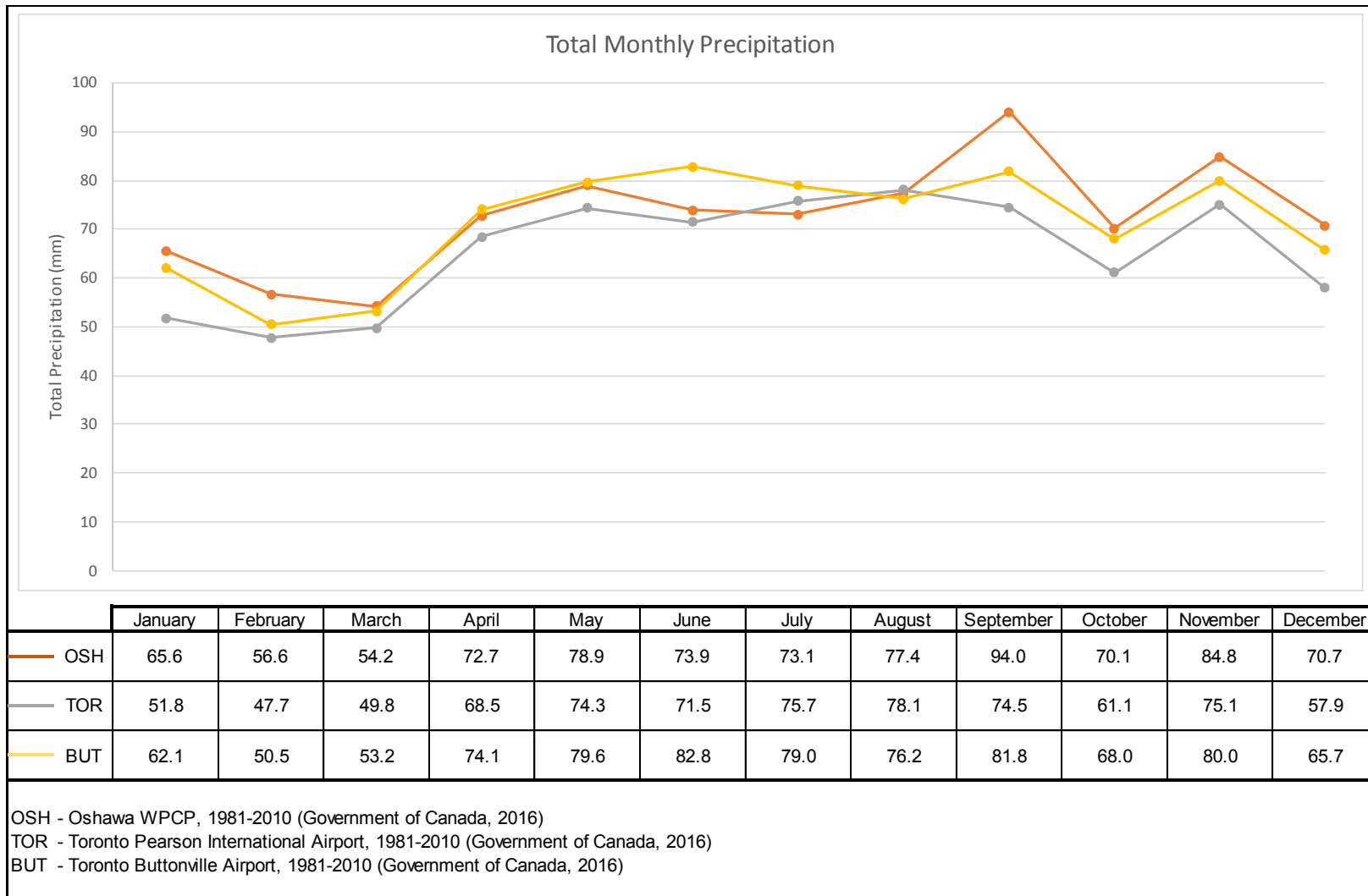

Figure 2.9: Comparison of Total Monthly Precipitation for Three Regional Meteorological Stations

2.3.1.3 Wind

The most recent consecutive five-year period of reliable wind data is 2011 to 2015. The data are summarized as a windrose in Figure 2.10. The 5-year average meteorological data from 2011 to 2015 are expected to be representative of current average meteorological conditions. During this period, calm winds, less than 2 m/s, were reported approximately 39% of the time while winds with measured speeds from 2 to 3 m/s and 3 to 4 m/s were observed approximately 21% and 18% of the time respectively.

The prevailing winds for the 2011 to 2015 period were from the north approximately 10% of the time, and the south-southwest approximately 9% of the time.

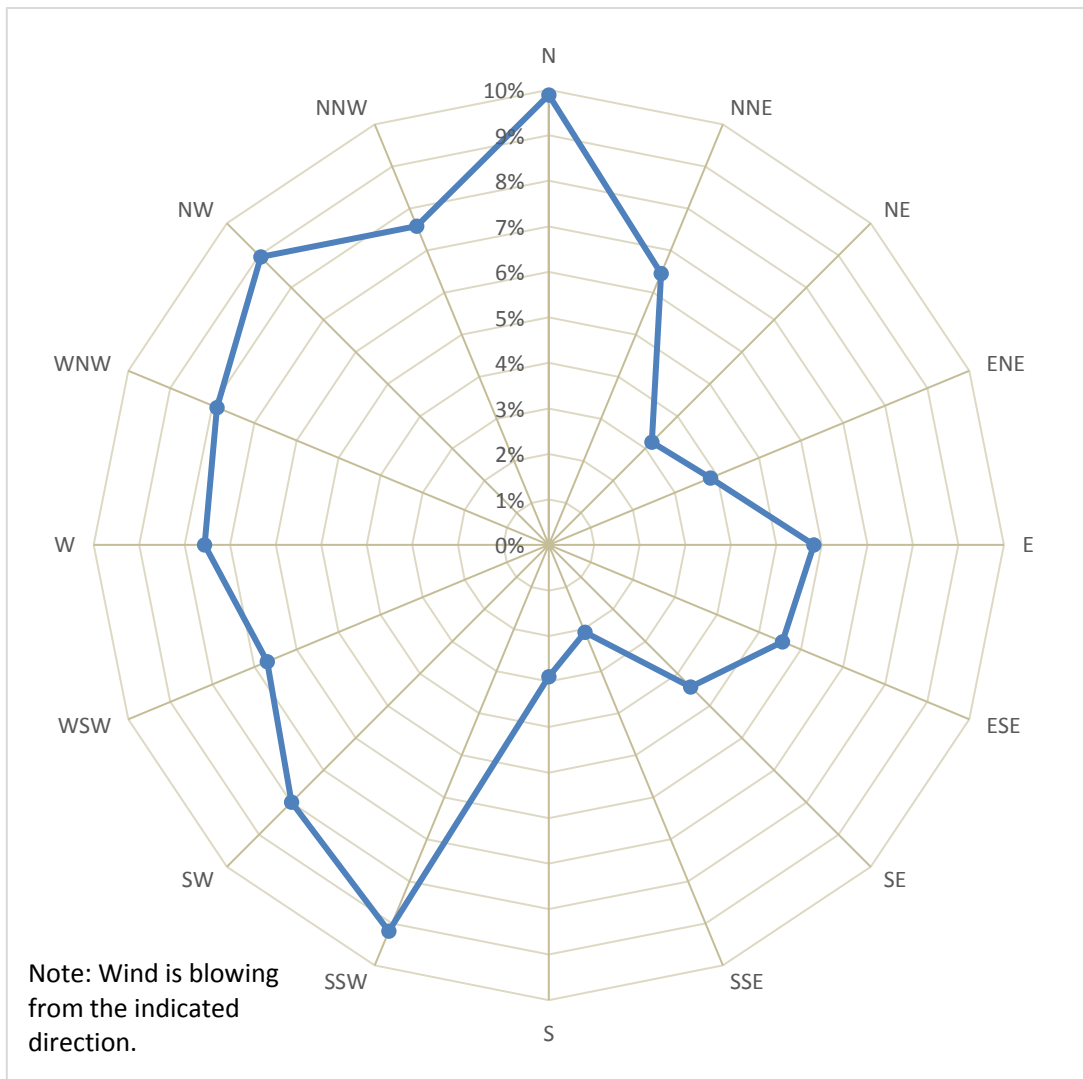

Figure 2.10: 2011 - 2015 Annual Average Windrose at 10-m Tower

2.3.2 Geology

A substantial body of information has been collected at the PN site through work carried out during previous investigations, including geological drilling investigations, monitoring well installations and sampling. These data have been summarized in the Pickering B Refurbishment Environmental Assessment (EA) (SENES, 2007e) and a more detailed discussion is provided in Golder (2007d). The following sections provide an overview of the regional and local bedrock and surficial geology, and a summary of bedrock and surficial geology for the PN site and offshore.

2.3.2.1 Bedrock

On a regional scale, the PN site is underlain by Ordovician age sedimentary rocks composed of nearly flat-lying shales and limestones that dip gently (1%) southward, characteristic of the north shore of Lake Ontario. The relatively undeformed Ordovician sequence lies unconformably upon gneiss crystalline Precambrian rocks that form the basement complex.

The bedrock beneath the site has been investigated by numerous geotechnical and hydrogeological investigations including over 500 boreholes drilled over the past 45 years (Golder, 2007d). A cross section of the subsurface conditions beneath the PN site and offshore is presented in Figure 2.11. In general, the bedrock surface is encountered at depths of approximately 10 m to 20 m below the surface with localized areas of low bedrock topography.

The stratigraphic sequence of the Ordovician shales that underlie the PN site, in descending order, include Blue Mountain Formation shale and Whitby Formation shaly limestone and shale, which overly a thick limestone sequence. The overlying shale sequence consists of the grey fissile shale of the Blue Mountain Formation, approximately 10 to 20 m thick, and the underlying black petroliferous shale of the Whitby Formation, approximately 5 to 7 m thick. The limestone sequence is composed of the Lindsay, Verulam, Bobcaygeon and Gull River Formations. The combined limestone sequence has a thickness of approximately 180 m. Underlying the limestone sequence are clastic sediments of the comparatively thin (12 m) Shadow Lake Formation which occur on the Precambrian basement complex (Golder, 2007d).

The surface of the bedrock sequence slopes southward from elevations of 68 metres above sea level (masl) at the north of the site to elevations of approximately 47 masl approximately 1.5 km offshore in Lake Ontario as shown in Figure 2.12 (Golder, 2007d). The projected local dip of the bedrock is southeastward at a generally uniform grade of 1% (Golder, 2007d). The bedrock surface directly beneath the PN site, in the vicinity of the units is relatively level, varying between elevations of approximately 58 m to 62 m, with a gentle southward dip of approximately 0.1% to 0.2%.

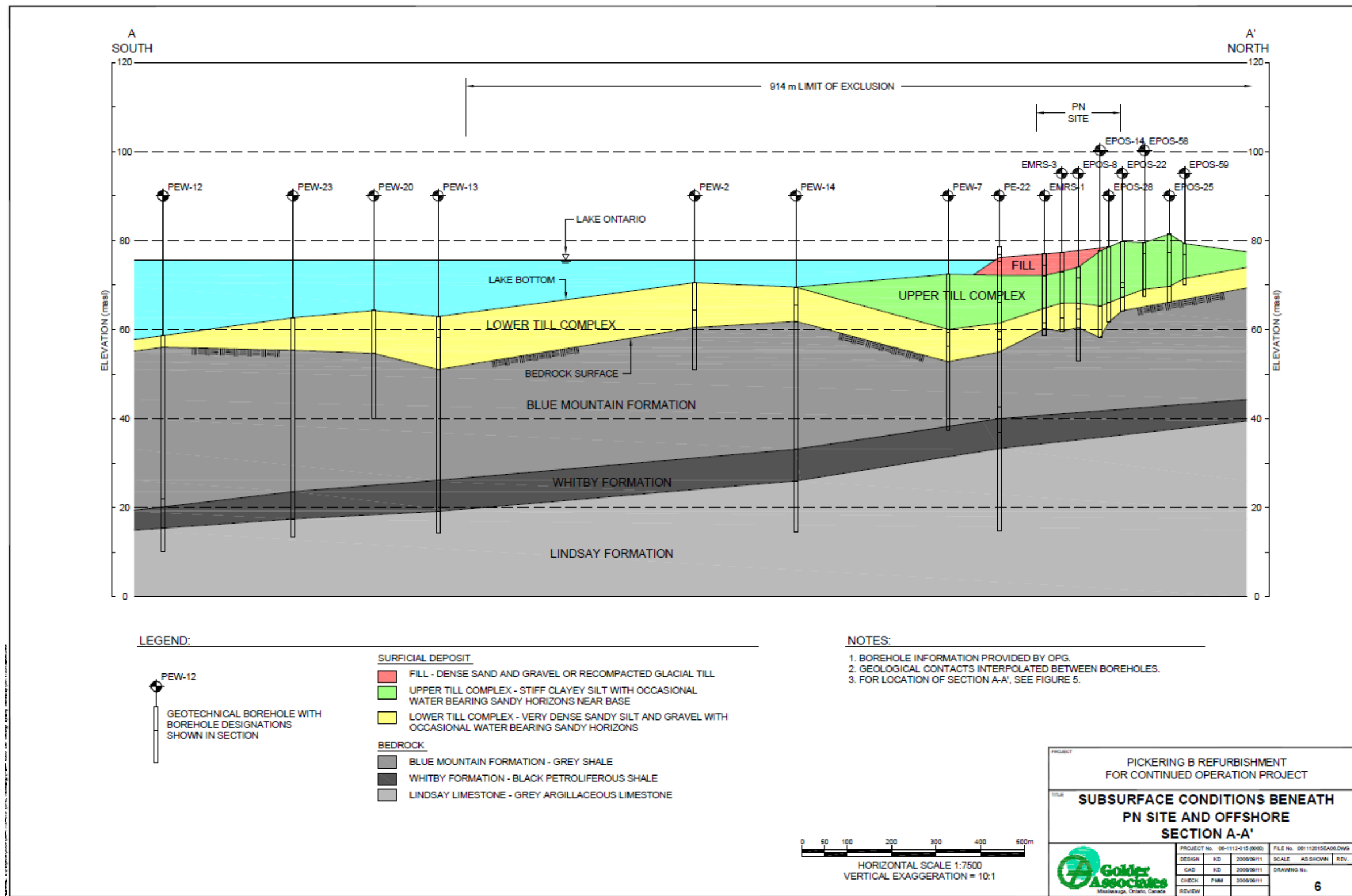

Figure 2.11: Subsurface Conditions Beneath the PN Site and Offshore Section A-A' (Golder, 2007d)

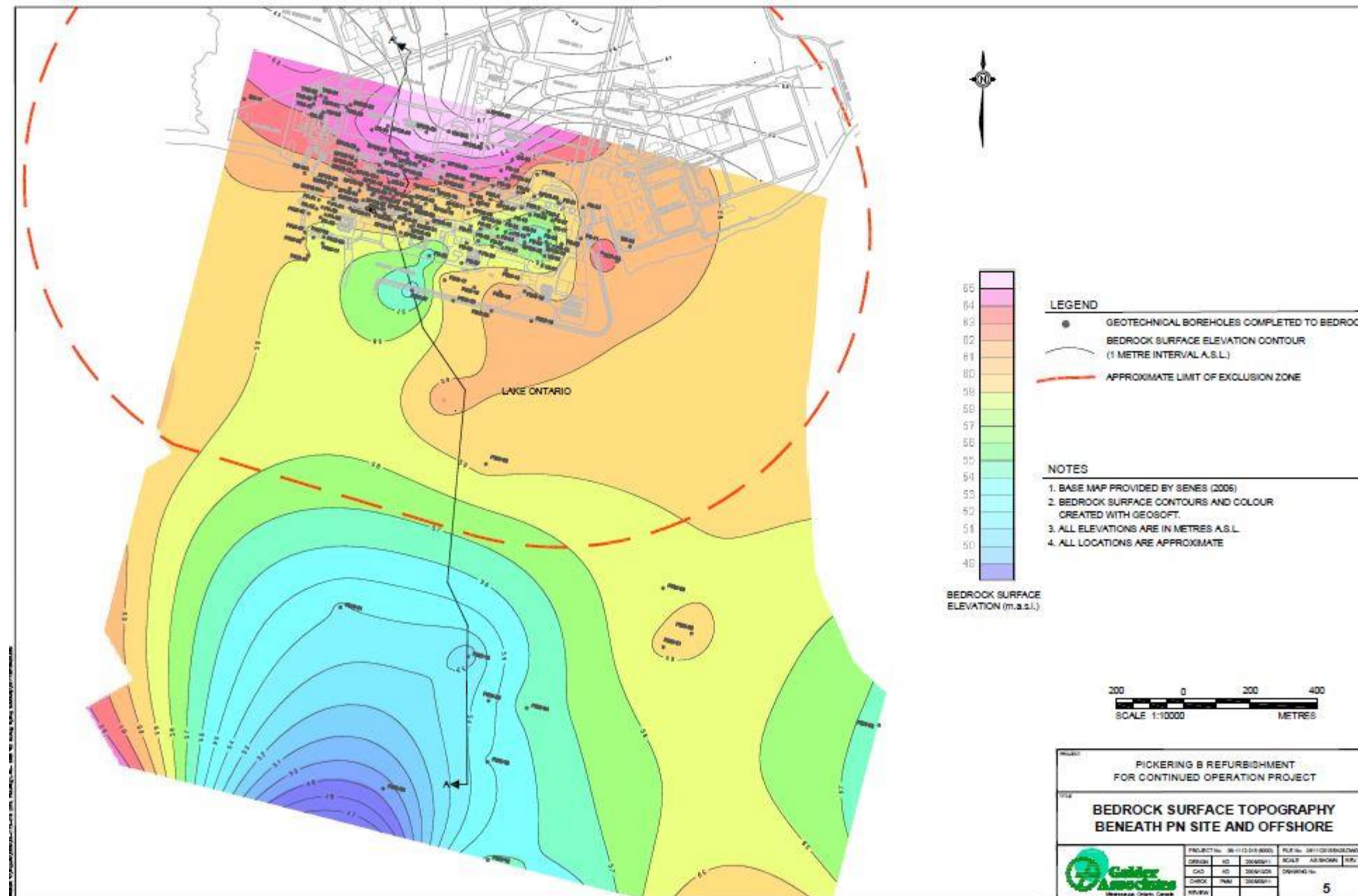

Figure 2.12: Bedrock Surface Topography beneath the PN Site and Offshore (Golder, 2007d)

2.3.2.2 Surficial Geology

The PN site is situated on the north shore of Lake Ontario between the Oak Ridges Moraine to the north and the Lake Ontario shoreline to the south. The Oak Ridges Moraine is situated approximately 20 km to 30 km inland from the north shore of Lake Ontario. It forms the regional height of land separating the Trent System and Lake Simcoe drainage to the north from Lake Ontario drainage to the south. The moraine is composed of thick deposits of glacial till and sand and gravel that are associated with hummocky terrain at the surface (Golder, 2007d). South of the moraine, the north shore of Lake Ontario is largely underlain by glacial till and glaciolacustrine deposits of clayey silt to silty clay composition. These deposits are exposed in bluffs along the lakeshore and in stream valleys throughout the area. Locally, the surficial geology predominantly comprises glacial till, or glaciolacustrine silts and clays overlying the till, which forms drumlin ridges oriented approximately northwest-southeast.

Investigations conducted in advance of the construction of PN U1-4 and U5-8 indicate that the pre-construction subsoils in the area of the existing plant generally consisted of glacial silt and sand tills up to 24 m thick overlying shale bedrock. Currently, the soil sequence overlying the bedrock beneath the PN site can be subdivided into three main layers comprising construction fill, a recent Upper Till Complex and an older Lower Till Complex overlying bedrock (Golder, 2007d) as illustrated in Figure 2.11. The elevations of the upper and lower soil complexes were found to range from about 67 masl to 79 masl, and 56 masl to 67 masl, respectively, within the main PN built area.

The fill material consists of either sand and gravel backfill that was placed for foundations, or recompacted clayey silt placed in the reclamation areas. The fill material underlies most of the PN site south of the former Lake Ontario shoreline. Structures such as the Reactor Buildings and Reactor Auxiliary Buildings were placed on 3 m to 6 m of compacted granular fill.

The Upper Till Complex forms a generally uniform blanket over a large portion of the site with a thickness that typically varies from 6 m to 15 m (Golder, 2007d). It generally consists of cohesive, soft to very stiff, moist, grey, clayey silt to silty clay, with sand and some gravel and occasional boulders; between 20% to 40% of the till is comprised of clay (Golder, 2007d). The Lower Till Complex is approximately 4 m to 12 m thick and directly overlies the shale bedrock. It generally consists of non-cohesive, very dense, grey, sandy silt to silty sand and gravel till, with a clay content of approximately 7% to 16% (Golder, 2007d). Water bearing layers and lenses of interglacial silt, sand and gravel have been encountered at the base of the upper soil complex and interbedded within the lower complex.

2.3.3 Hydrogeology

On a regional scale, the permeable layers of sands, or sand and gravels buried within and between low permeability till deposits constitute aquifers that support groundwater flow.

The tills typically have low permeability due to their fine granularity and behave as aquitards, restricting infiltration and the recharge of water to the permeable layers. The bedrock deposits of shale and limestone that underlie the surficial deposits also have low permeability, except for some weathered zones and open fractures. The exposed areas of sand and gravel within the Oak Ridges Moraine are a significant regional source of groundwater recharge from precipitation. Once recharged, the direction of groundwater flow in the buried sand and gravel deposits generally parallels that of surface streams, flowing away from the height of land formed by the moraine toward adjacent areas to the north and south. Some of the groundwater recharged in the Oak Ridges Moraine subsequently discharges into stream beds providing baseflow that maintains the streams during the dry periods of the year when there is little or no surface runoff.

The regional direction of groundwater flow south of the Oak Ridges Moraine is southward toward Lake Ontario and generally parallel to the land slope. On a local scale, groundwater flows toward one of three surface water bodies in the vicinity of the PN site, Frenchman's Bay to the west, Duffins Creek to the east and Lake Ontario to the south. Both Frenchman's Bay and Duffins Creek flow into Lake Ontario.

There are four main groundwater flow systems present below the PN site reflective of the stratigraphy layers (fill, upper till, lower till and bedrock) (Golder 2007d). Each of the four main layers has its own specific hydrogeological character. Shallow overburden groundwater is found in the shallow, more permeable overburden layers of fill, organic clayey silt to silty clay and brown sandy to clayey silt till. An intermediate overburden groundwater unit is within a layer of grey clayey silt to silt clay till. A deep overburden groundwater flow system is within a dense, grey, sandy silt till, while a deep bedrock flow unit is within the shale bedrock. Groundwater elevations are typically measured by OPG annually in each of the four main groundwater flow systems designated as, from shallow to deep: shallow/water table; intermediate overburden; deep overburden; and deep bedrock.

The results of historic site investigations and monitoring have provided an understanding of the groundwater flow system below the PN site. Groundwater contour maps for the fourth quarter of 2015 are shown in Figure 2.13 and Figure 2.14 for the shallow and intermediate groundwater systems. The 2015 data provide a good understanding of groundwater flows at the PN site because annual monitoring has shown that the groundwater flow has not changed significantly over time (OPG, 2016d). Groundwater elevation monitoring over the past few years has also indicated that there is generally no significant seasonal change in the shallow groundwater flow directions.

In general, vertical flow between the flow systems is downward in the overburden and upward in the bedrock, as would be expected for regional groundwater discharge to Lake Ontario.

The flow in the area of the PN site is significantly influenced by the inactive Turbine Auxiliary Bay foundation drainage system located beneath the deep building foundations.

The inactive Turbine Auxiliary Bay foundation drainage system is used to control groundwater beneath the floors. Groundwater from the Turbine Auxiliary Bay foundation drains flows into each unit's sump and then is discharged to the intake channel via pumping. Groundwater from the granular horizons in the Lower Till and the granular foundation backfill is collected in the foundation drains. The drainage system has locally lowered groundwater levels below the level of Lake Ontario, creating a hydraulic sink that captures groundwater beneath and immediately adjacent to the PN reactor buildings (SENES, 2007e). Measured flow into the Turbine Auxiliary Bay foundation drains is on the order of about 25 and 77 m³/day for PN U1-4 and U5-8, respectively (CH2M Gore and Storrie, 2000).

Estimated horizontal flow velocities in groundwater across the site range from 0.3 to 11 m/y (CH2M Gore and Storrie, 2000).

Shallow Groundwater

Shallow groundwater levels are typically within 1 m to 4 m of ground surface throughout most of the site. The highest groundwater levels occur within the area of high ground associated with the East Landfill and the lowest levels occur around the reactor buildings and turbine halls. The shallow groundwater levels measured around the reactor buildings are slightly below lake level, likely reflecting the influence of the reactor building foundation drains and the deep drains beneath the Turbine Auxiliary Bay (Golder, 2007d). All groundwater that discharges to the deep foundation drains flows to each unit's sump where it is then pumped to the inactive drainage common header, followed by a holding pond, and then discharged to the forebay. Closer to the forebay area around the standby generators, the water table is at or slightly above lake level. At the north side of the Turbine Auxiliary Bay within the granular backfill of the CCW discharge duct, the shallow groundwater levels are above the lake level and there is little indication of drawdown to the deep foundation drains.

Shallow groundwater flow directions at the PN site are typically toward Lake Ontario except within the granular fill immediately adjacent to and beneath the powerhouse area at PN U1-4 and U5-8 where groundwater levels are below the level of Lake Ontario and groundwater flow is directed toward the deep foundation drains (Golder, 2007d). Locally, a number of features influence groundwater flows including the fill materials, the East Landfill, the Montgomery Park Road and different surface and subsurface structures. The area of the East Landfill (Figure 2.13) represents a groundwater recharge area, with radial flow outward from the landfill area in all directions.

A groundwater divide appears to be present along the northern portion of the PN site that generally runs parallel to Montgomery Park Road. Shallow groundwater north of the Montgomery Park Road flows west towards Frenchman's Bay. In the area south of Montgomery Park Road the direction of groundwater flow is generally to the south towards the station buildings and Lake Ontario. Higher rates of groundwater flow are associated

with backfill beneath the building structures, such as the reactor buildings, auxiliary reactor buildings, and the backfill of the CCW intake and discharge ducts. The southerly flow is also locally influenced by structures, including: the Turbine Auxiliary Bay till foundation drain system that acts as a hydraulic sink for the shallow groundwater; and a sump at the base of a ramp to the east of the Vacuum Building that also acts as a local hydraulic sink and results in a small groundwater divide between the reactor buildings and Lake Ontario (Figure 2.13). The Vacuum Building ramp sump discharges to the stormwater sewer system.

Intermediate Groundwater

The intermediate groundwater flow system is similar to the shallow system (Figure 2.14), with the East Landfill acting as a recharge area, groundwater north of Montgomery Park Road flowing westward towards Frenchman's Bay and groundwater south of Montgomery Park Road flowing southward towards Lake Ontario. Local influences affecting intermediate groundwater flow include the Turbine Auxiliary Bay drains and Vacuum Building Ramp Sump which create artificial hydraulic sinks similar to those observed in the shallow groundwater system, limiting groundwater flow towards the lake south of the Reactor buildings.

Deeper Groundwater

Due to a limited number of wells located within the deep overburden and bedrock, the deeper groundwater flow systems are less well defined, but the limited data indicate flow towards Lake Ontario with some influence of the Turbine Auxiliary Bay foundation drains. Water levels observed in the Lower Till Complex in the vicinity of PN U1-4 and U5-8 indicate that the deep foundation drains beneath the units are controlling the groundwater levels in the Lower Till Complex through dewatering, indicating that these deep horizons are hydraulically isolated from Lake Ontario (Golder, 2007d). The data also show that the shallow bedrock is typically not influenced by non-nuclear COPCs or by tritium. The shale bedrock at depth beneath the site is of low permeability and is associated with limited rates of groundwater flow except for occasional more permeable fractures that are more prevalent near the bedrock surface (Golder, 2007d).

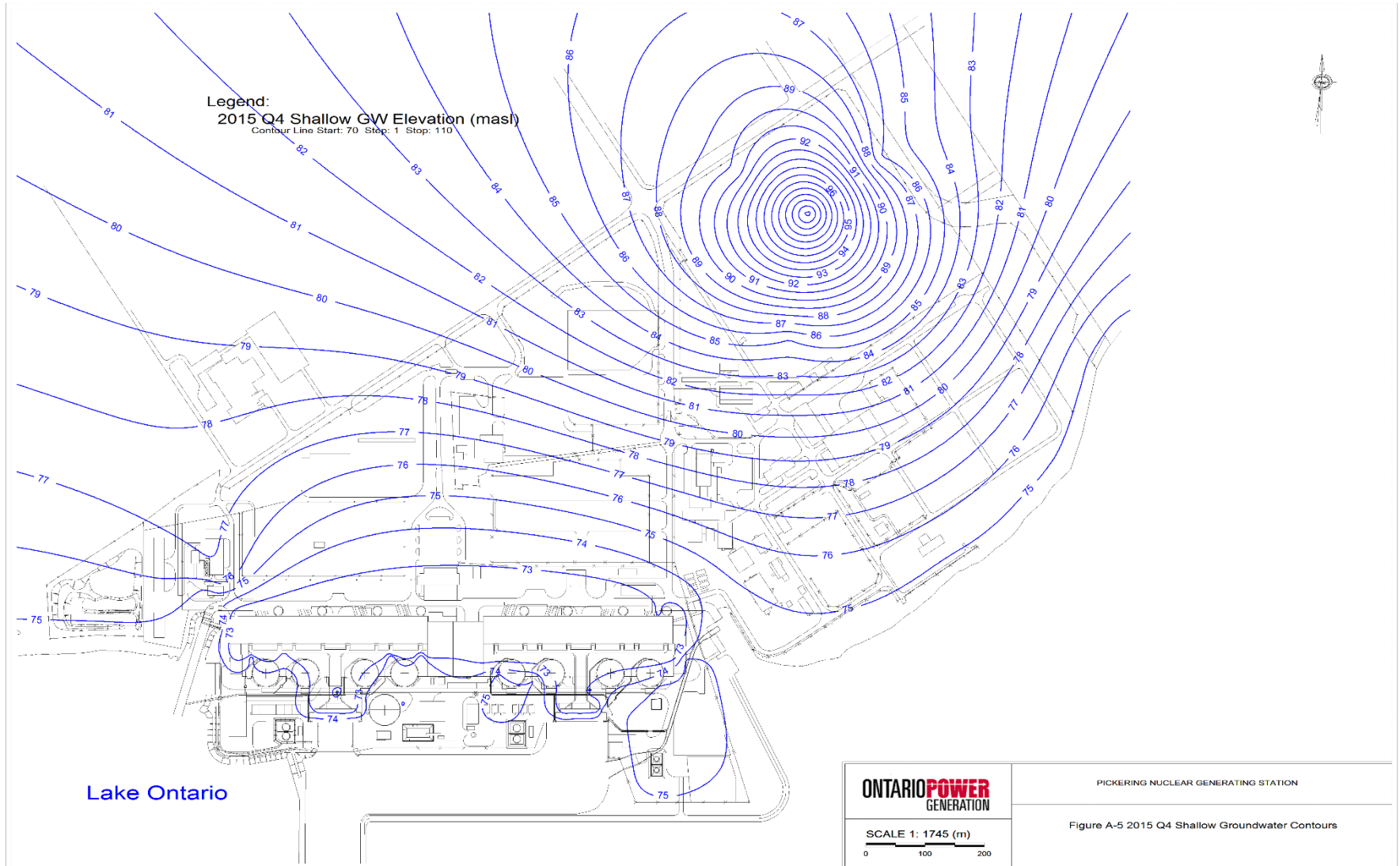

Figure 2.13: Site Groundwater Flow Conditions – Shallow Groundwater Elevation Contours (OPG, 2016d)

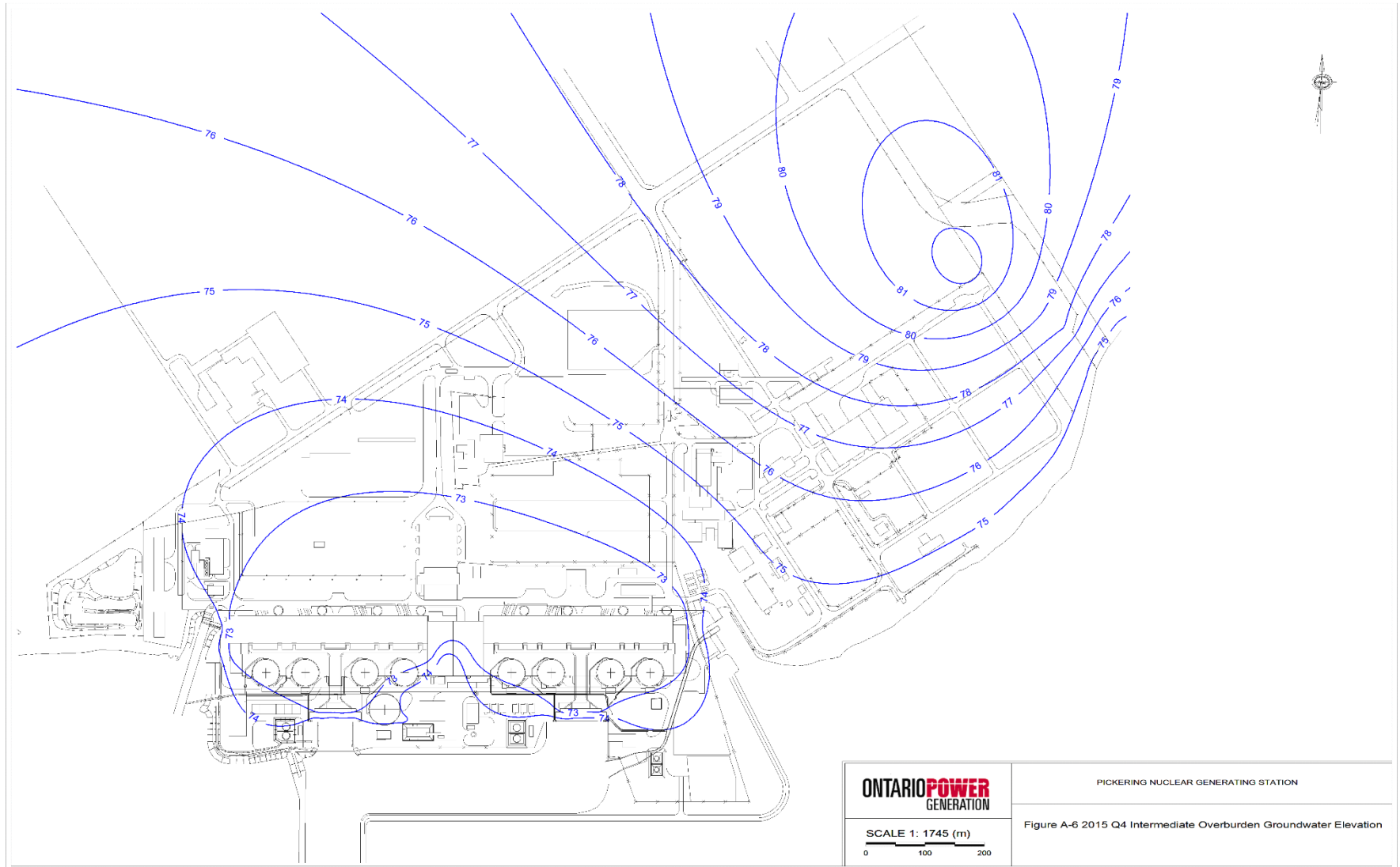

Figure 2.14: Site Groundwater Flow Conditions – Intermediate Groundwater Elevation Contours (OPG, 2016d)

2.3.4 Hydrology

2.3.4.1 Lake-wide Circulation and Nearshore Currents

The PN site is situated on the north shore of Lake Ontario. Lake-wide circulation in Lake Ontario is primarily driven by wind and by seasonal temperature effects. The nearshore region currents tend to be driven by brief patterns of strong winds exerting stress at the water surface. The nearshore current typically has a breadth of about 7 km in spring and as much as 10 km in summer and fall (Golder, 2007a).

Table 2.9 shows the frequency of lake current flowing toward each direction and the maximum speed that occurred in each direction for the monitoring period from 2011 to 2015 inclusive. Table 2.10 shows the depth averaged lake current direction and speeds for the same period. Average lake current data are summarized for easterly, NE, ENE, E, and ESE, and westerly, SW, WSW, W, and WNW, lake currents. During the 5-year period including 2011 to 2015, the average easterly and westerly current speeds were 22.5 cm/s and 16.8 cm/s respectively.

Table 2.9: Lake Current Data from 2011 to 2015

Direction "To"	N	NNE	NE	ENE	E	ESE	SE	SSE	S	SSW	SW	WSW	W	WNW	NW	NNW	Easterly	Westerly
Total Number of Measured Hours	54041	80234	143805	539228	378420	183758	119648	90029	91316	123172	319549	414771	154521	75381	52940	47769	1209952	1000912
Percent of Total Measured Hours	1.9%	2.8%	5.0%	18.8%	13.2%	6.4%	4.2%	3.1%	3.2%	4.3%	11.1%	14.5%	5.4%	2.6%	1.8%	1.7%	42.2%	34.9%
Average Speed (cm/s)	18.31	23.68	26.21	23.06	20.75	23.81	23.57	22.29	21.52	19.31	15.55	16.09	16.26	15.80	15.55	15.95	22.82	16.12
Maximum Speed (cm/s)	210.40	210.90	214.21	214.22	218.46	217.00	213.68	216.67	216.80	220.73	218.18	217.66	216.51	214.11	214.85	209.25	220.11	220.23

Notes:
 Easterly direction includes NE, ENE, E, and ESE.
 Westerly direction includes SW, WSW, W, and WNW.

Table 2.10: Current Speed and Direction from 2011 to 2015

	Depth averaged Speed - E cm/s	Depth averaged speed - W cm/s	Percent of Time - E	Percent of Time - W
Jan	28.0	18.0	9.45%	4.45%
Feb	29.2	18.3	8.93%	4.07%
Mar	23.1	19.4	7.57%	4.75%
Apr	22.2	19.0	8.52%	7.00%
May	18.9	13.4	6.62%	13.00%
Jun	15.0	13.0	9.38%	10.79%
Jul	16.6	12.8	8.11%	10.41%
Aug	20.5	15.6	7.62%	11.75%
Sep	21.3	17.0	8.37%	10.56%
Oct	22.8	18.9	8.81%	9.61%
Nov	27.2	16.6	8.46%	7.19%
Dec	24.7	19.1	8.14%	6.42%
Average of monthly averages	22.5	16.8	-	-

Notes:

Easterly direction (E) includes NE, ENE, E, and ESE.

Westerly direction (W) includes SW, WSW, W, and WNW.

Nearshore lake currents are affected by the existing operation of the PN units. Some localized effects are observed near water intake and water discharge points. Water velocities in the vicinity of intake groynes are directed toward the plants and a zone of inflowing water is evident around the intake. With PN U1 and U4 and U5-8 running, typical water withdraw between the intake groynes and into the plant via the intake channel is estimated at 190 m³/s based on rated condenser CCW pump capacities and service water demand (SENES, 2007e).

2.3.4.2 Lake Water Temperature

Lake Ontario is generally classified as a dimictic lake because it undergoes a complete cycle of isothermal and vertically stratified conditions in a year. The thermal structure generally depends on the season because of large annual variation in surface heat fluxes. In spring and early summer, heating of the lake surface gradually results in potential formation of thermal stratification conditions, with warmer water at the surface layer and

cooler water in the bottom layer. Since nearshore water is heated up more rapidly than offshore water in spring, the depth of the thermocline in shallow water near the shore is greater than the depth of the thermocline in deep water offshore. As deeper water becomes stratified, the thermal bar (i.e., the temperature gradients on the same horizontal plane) moves progressively farther offshore, and it disappears when most of the lake is stratified sometime in June. The lake water is isothermal in fall and winter, or sometimes very weakly stratified in winter. In summer, the nearshore vertical temperature profile demonstrates a stable temperature stratification with warmer water in the surface layer and cooler water in the bottom layer. The depth of the summer thermocline ranges from 5 m to 10 m.

Table 2.11 presents monthly water temperature statistics for Lake Ontario based on monitoring data from 1970 to 1988 for two representative water depths of 1 to 2 m (surface), 8 m and 12 m at an ambient location off PN. These data indicate that the ambient water temperature is lowest in February and peak in August. The year-to-year variation in monthly mean temperatures is larger in the summer months than in the winter months and is similar at different depths.

Table 2.11: Nearshore Mean Monthly Ambient Temperatures (°C) for Lake Ontario for the 1970-1988 Period (Golder, 2007a)

Month	Nearshore Surface Temperature (1970-1988)	12-m Depth Temperature (1972-1988)
January	1.6	2.2
February	1.2	1.8
March	2.4	2.3
April	5.3	3.9
May	7.5	5.8
June	10.1	7.4
July	12.9	8.7
August	17.3	13.5
September	14.5	12.0
October	9.9	8.5
November	6.0	5.9
December	3.0	4.3

2.3.4.3 Thermal Plume Vertical Extent

Between 1986 and 1988, 12 synoptic thermal plume surveys and in-situ water temperature measurements, six during warm weather conditions and six during cold weather conditions, were conducted (Burchat, 1990, cited in Golder, 2007a). Warm weather conditions refer to ambient lake water temperatures greater than 4°C and occur in spring, summer, and fall. Cold weather conditions refer to ambient lake water temperatures less than 4°C and occur only in winter. The study was designed to determine the combined effect of the PN units on

the aquatic environment with five to seven units in operation. Details of the study are provided in Golder (2007a).

The historical data for the 12 synoptic surveys showed that the depth of the thermal plumes under warm weather conditions was 1 to 2 m and that the thermal plumes flowed in the direction of the prevailing wind. The thermal plumes under warm weather conditions extended mostly to the west. The thermal plumes under cold weather conditions extended mostly along the shore and to the east and deeper into the water column.

The historic data also indicated that thermal plumes in winter were generally larger in extent than thermal plumes in summer. Based on a criterion of 2°C above the ambient water temperature, the area of combined PN thermal plumes ranged from 1.5 to 8 km² at the water surface regardless of warm or cold weather conditions, and from 0.5 to 3 km² at the bottom during cold weather conditions. Results of numerical modelling for winter plumes are presented in Golder (2007b).

In 2006 and 2007, a series of anchored buoys, each with temperature loggers at three depths, were set in the vicinity of PN U5-8 to monitor water temperature during normal operations and algae events (Ager *et al.*, 2008). Water temperature contours corresponding to algal events for October 2006 and August - October 2007 were summarized in the report. The results of the field study indicated that PN U5-8 was the dominant thermal discharge plume because of its greater discharge volume and higher discharge temperature differential. PN U1-4 had minimal effects on thermal plumes throughout the study period, because of reduced discharge temperatures and volumes at this Station. The temporal changes observed in the temperature isopleths at the three depth contours were consistent with the development of an elastic floating thermal plume, following a variable initial period of vertical mixing in the vicinity of the PN U5-8 discharge. The development of the floating thermal plume resulted from temperature related differences in the density of the discharge and lake water layers.

Recent studies during three consecutive winter periods from 2009/10 to 2011/12 were performed to measure lake substrate temperatures in the thermal plume in the vicinity of PN and at reference areas (OPG, 2013d). The study was conducted as follow-up to the Environmental Assessment for the Pickering A Return to Service and the Pickering B Refurbishment to confirm predicted impacts on Round Whitefish spawning or larval development relative to the lake wide population. To represent the region impacted by the PN thermal plume, temperature monitoring locations were established between the Pickering "B" discharge and Duffins Creek. Reference locations included were Thicksen Point (Whitby, approximately 13.5 km east of the Pickering site) and Bonnie Brae Point (Oshawa, approximately 19.5 km east of the Pickering Site).

The studies demonstrated that the average substrate temperatures at any one location and the degree of difference between substrate temperatures in the area influenced by the thermal plumes and reference areas varied from year to year. Average winter substrate

temperatures were slightly warmer in the plume area (by 1 to 2 degrees celcius) than at the reference locations from December to early March and were similar to reference locations for the remainder of the incubation period to hatch.

2.3.4.4 Thermal Plume Horizontal Extent

The horizontal extent of the thermal plume for PN was studied in 2006 and 2007 (Ager et al., 2008). The greatest extent of the surface plumes (based on a 10°C differential between the ambient temperatures and PN intake temperature) for 2006 were roughly 33,000 m², and 40,000 m² during October 11-12 and October 27-28 events, respectively. The greatest extent of the surface plumes for 2007 were roughly 53,000 m², 34,000 m² and 63,000 m² during August 21-29, October 9-10, and October 26 -28 events, respectively. Thermal plumes at the middle and bottom contours were more localized. Table 2.12 provides the estimated areas of the surface, middle and bottom thermal plumes where the temperature was greater than 10°C above the PN U5-8 intake temperature observed during the 2006 – 2007 algal events. The depth of each water temperature contour (surface, middle, and bottom) was variable.

Table 2.12: Estimated Area of the Surface, Middle and Bottom Thermal Plumes (10°C above the Units 5-8 Intake Temperature) during Algal Events Observed in 2006 and 2007

Event		Temperature Contour	
Year	Date	10°C above the PN U5-8 Intake Temperature	
		Depth	Maximum Area (m ²)
2006	October 11-12	Surface	33,425
		Middle	9,750
		Bottom	8,325
2006	October 27-28	Surface	40,800
		Middle	13,325
		Bottom	12,850
2007	August 21-29	Surface	53,475
		Middle	24,000
		Bottom	3,300
2007	October 9-10	Surface	33,975
		Middle	20,100
		Bottom	125
2007	October 26-28	Surface	62,625
		Middle	24,175
		Bottom	11,375

Source:

Tables 9 to 14, Ager *et al.*, 2008.

2.3.4.5 Surface Drainage

Lake Ontario is the farthest downstream of the five Great Lakes. It is the smallest in surface area but is substantially larger in volume, 1,640 km³, than Lake Erie, which is located immediately upstream and empties into Lake Ontario via the Niagara River. The land area draining directly to Lake Ontario is approximately 64,030 km². The Niagara River constitutes the single most significant inflow to Lake Ontario. The natural outlet from Lake Ontario is the St. Lawrence River.

The Lake Ontario watershed boundary in the region of the PN site is defined by a topographic high corresponding to the Oak Ridges Moraine which forms the watershed divide between Lake Ontario and Georgian Bay. From west to east, the main drainages to Lake Ontario within the region, include Don River, Highland Creek, Rouge River, Petticoat Creek, Frenchman's Bay, Duffins Creek, Carruthers Creek, Lynde Creek, Oshawa Creek, and Harmony Creek and Farewell Creek watersheds.

The PN site is surrounded by two major watersheds: the Rouge River watershed to the west and the Duffins Creek watershed to the east, as shown in Figure 2.15. Two smaller watersheds are located between the Rouge River watershed and the PN site. These are the Petticoat Creek watershed and the watershed draining to Frenchman's Bay, which are 26 km² and 22 km², respectively. The watershed draining to what has been referred to as the "Hydro Marsh", located directly west of the PN site (see Figure 2.16), includes flow from Krosno Creek which has a watershed of 0.7 km² and is a tributary of Frenchman's Bay. Krosno Creek also drains 0.14 km² of Hydro One's central maintenance and storage areas north of Montgomery Road.

Drainage in the PN site is a mix of ephemeral swales, ditches, culverts and storm sewers. Stormwater runoff from the PN site is collected by the stormwater drainage system and directed through drainage pathways south to Lake Ontario. No major watercourses traverse the SSA and no waterbody other than a small (5000 m²) isolated wetland known as the Southeast Wetland is located in the SSA. This small isolated wetland, which lies in the southeast corner of the PN property at the foot of Montgomery Park Road was once farmland and was created during the construction of PN as a result of landfilling activities. The Southeast Wetland receives drainage from the area around the former construction landfill within the SSA, and at best remains seasonally wet. Figure 2.16 provides a site plan for the PN site including the location of Hydro Marsh, the Southeast Wetland Area, PN U1-4 and U5-8 discharges and the PN water intake channel. In addition, there is a small manmade ephemeral pond in Alex Robertson Park.

Figure 2.17 presents the catchment areas for the PN site.

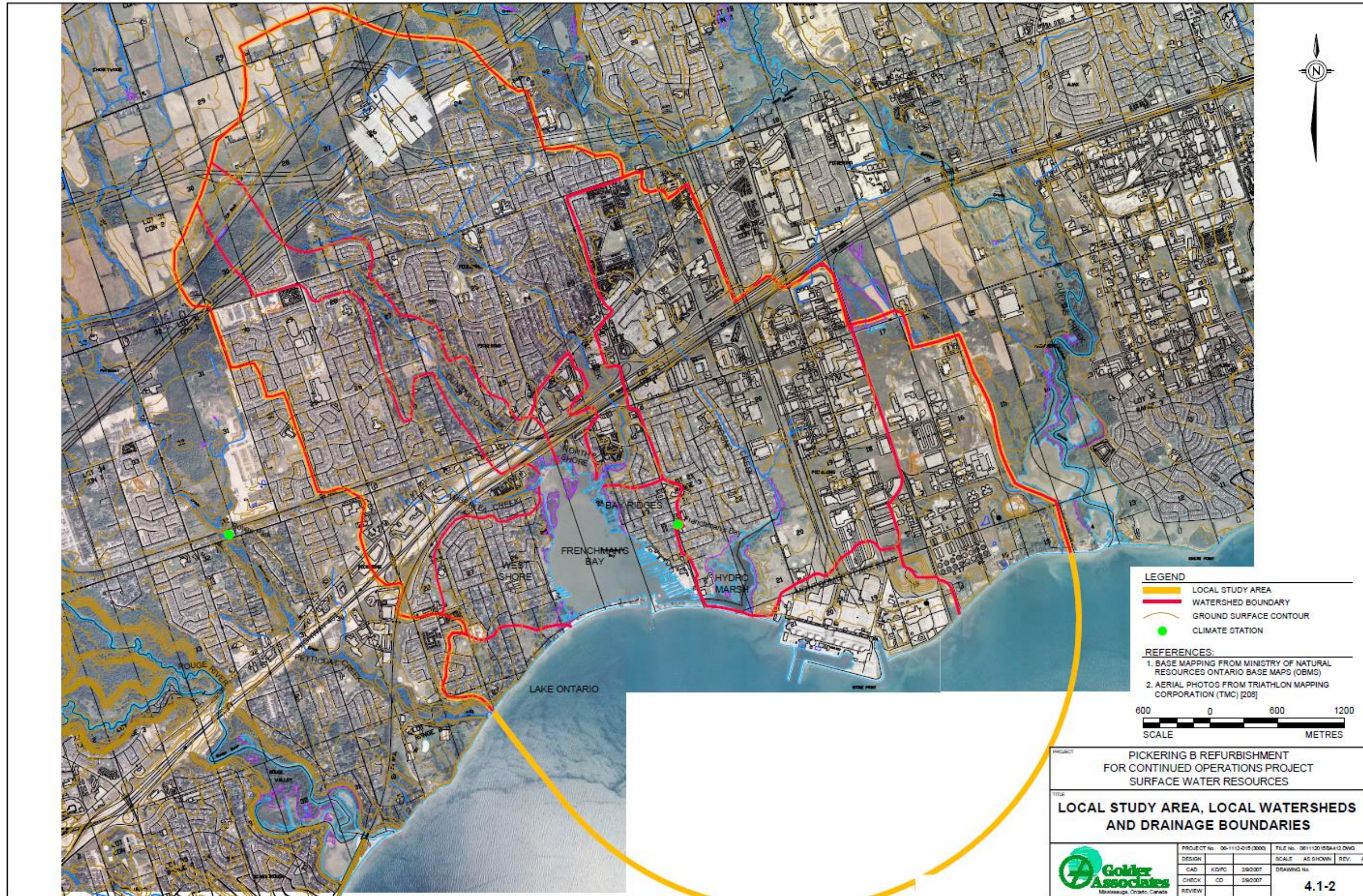

Figure 2.15: Local Study Area for Surface Water Resources, Local Watersheds and Drainage Boundaries (Golder, 2007a)

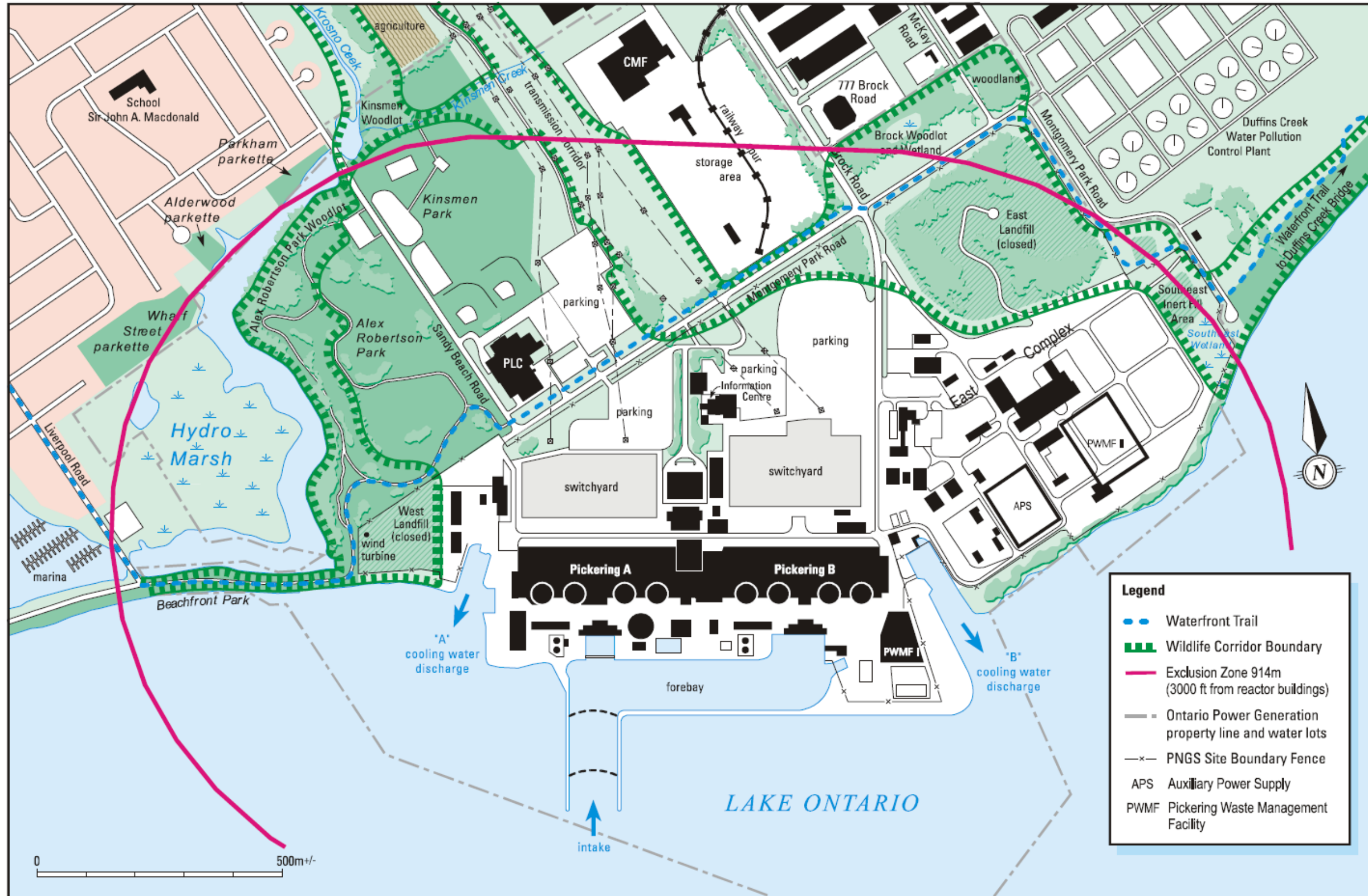

Figure 2.16: PN Site Plan (Golder, 2007a)

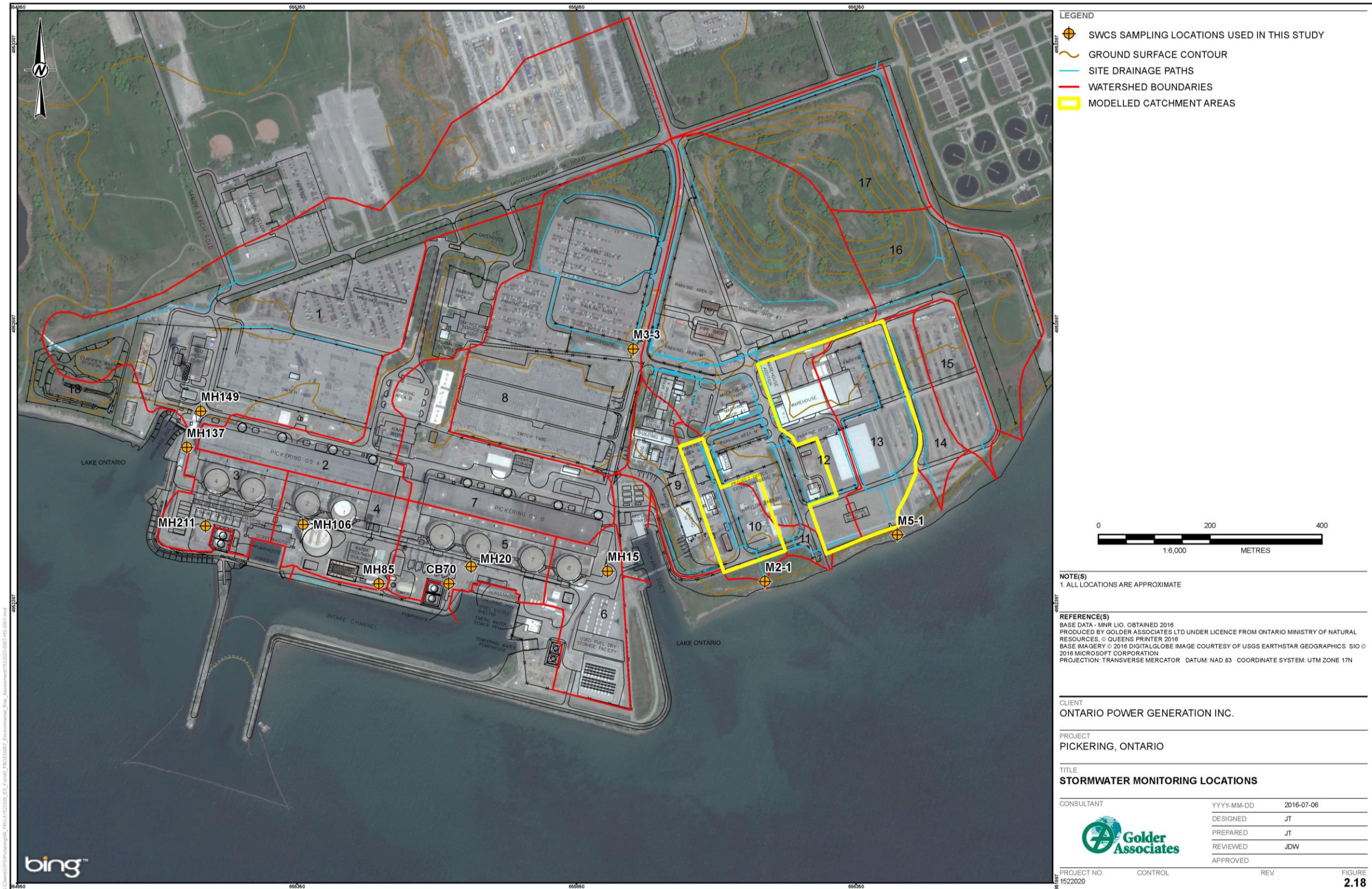

Figure 2.17: Catchment Areas for Pickering Nuclear and Stormwater Sampling Locations

2.3.5 Vegetation Communities

This section provides a brief overview of regional vegetation communities and summarizes existing vegetation communities located in the terrestrial SSA, as shown on Figure 2.18. The site, local and regional vegetation communities and other components of the terrestrial environment are briefly described below and in greater detail in Golder (2007c).

Much of the regional area has been cultivated over the past century. Accordingly, the dominant vegetation cover is related to agricultural use, including cash crops and pasture land. Other natural vegetation features are associated with valley lowlands associated with rivers and creeks, and the Lake Ontario shoreline environment. The flora of the RSA generally falls into the Niagara section of the Deciduous Forest Region (Rowe, 1972 as cited in Golder, 2007c). Dominant tree species in the natural forest areas in the vicinity of the PN site include: beech, sugar maple, basswood, red maple, white oak and bur oak. The coastal wetlands, located between the permanent, deep water of the lake and the dry uplands area, contain a mix of plant communities. Examples of vegetation communities in coastal wetlands include treed and thicket swamps, wet grass and sedge meadows, and emergent marshes that contain plants such as cattails and bulrushes. Coastal wetlands often contain interspersed pockets of open water that support submerged and floating leafed plants such as pondweeds and waterlilies.

Vegetation communities within and in the vicinity of the PN site are identified in Golder (2007c) shown on Figure 2.18, and from Toronto and Region Conservation Authority (TRCA) studies from 2009 to 2015 (TRCA, 2014 and 2015), shown on Figure 2.19.

The vegetation communities in Golder (2007c) were identified based on the Ontario Ministry of Natural Resources (OMNR) Ecological Land Classification (ELC) for Southern Ontario (Lee *et al.*, 1998, cited in Golder, 2007c). The vegetation communities are classified into four terrestrial communities (#1 to #4), six wetland communities (#5 to #10), one open water community (#11) and four cultural communities (#12 to #14). As shown in the figure, the portion of the PN site south of Montgomery Park Road is largely dedicated to industrial use while most of the PN site north of Montgomery Park Road is vegetated. The vegetated lands north of Montgomery Park Road are occupied by public parkland, athletic fields and a transmission corridor. This is consistent with site observations by an ecologist during an inspection on May 20, 2015.

In 2009, Toronto and Region Conservation Authority (TRCA) biologists were contracted to establish a terrestrial long-term monitoring project on PN property (OPG, 2011d), following the conservation authority's regional monitoring protocol in forest, wetland and meadow habitat types. Monitoring stations are presented in Figure 2.19. The purpose of the inventory was to detect changes and trends in the flora and fauna communities over time. A summary analysis and report was completed after 5 years of data collection from 2009 to 2013 (TRCA, 2014). Monitoring results for 2009 to 2015 are summarized in this report (TRCA, 2014 and 2015).

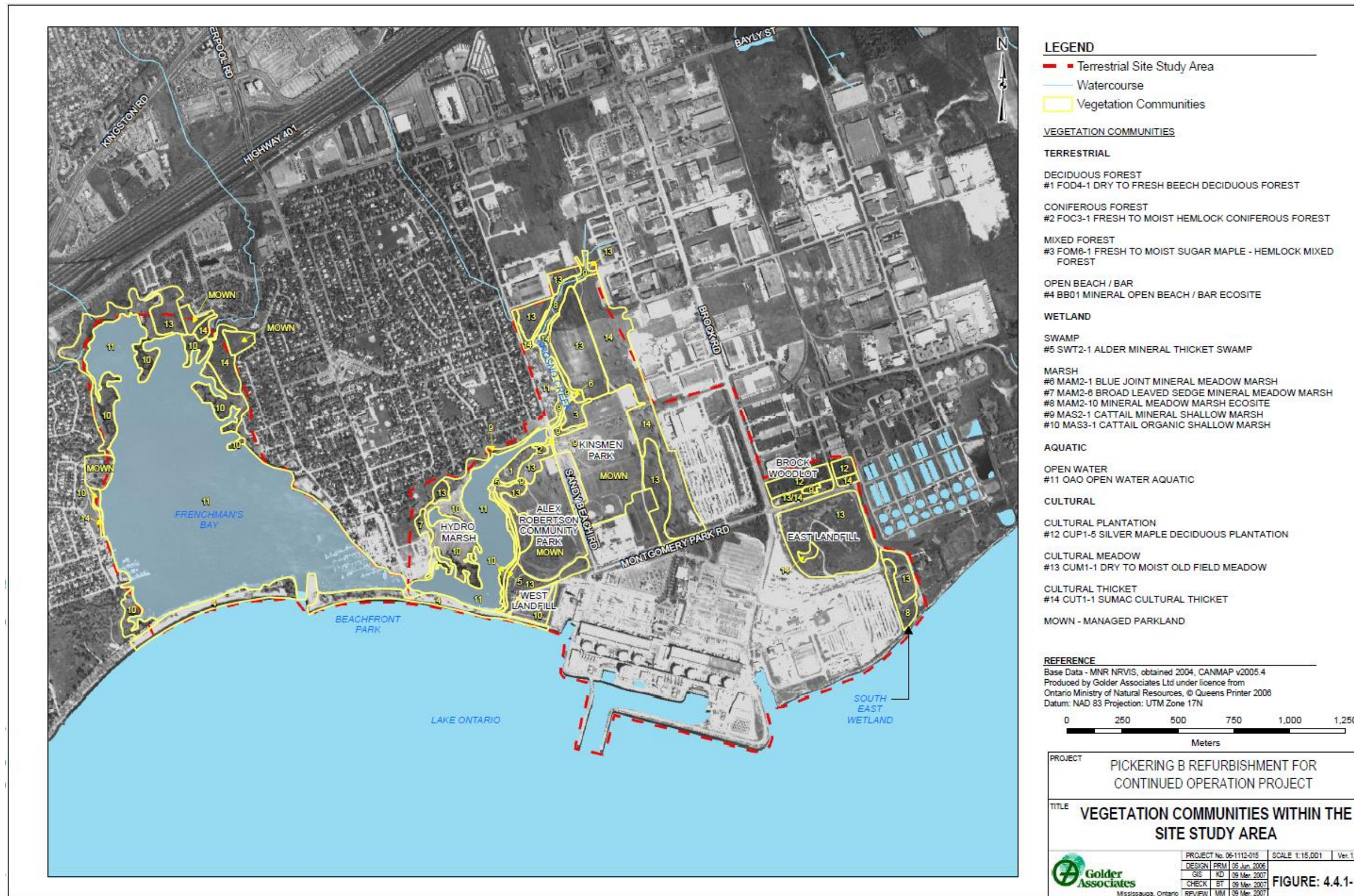

Figure 2.18: Vegetation Communities Within and in the Vicinity of the PN Site (Golder, 2007c)

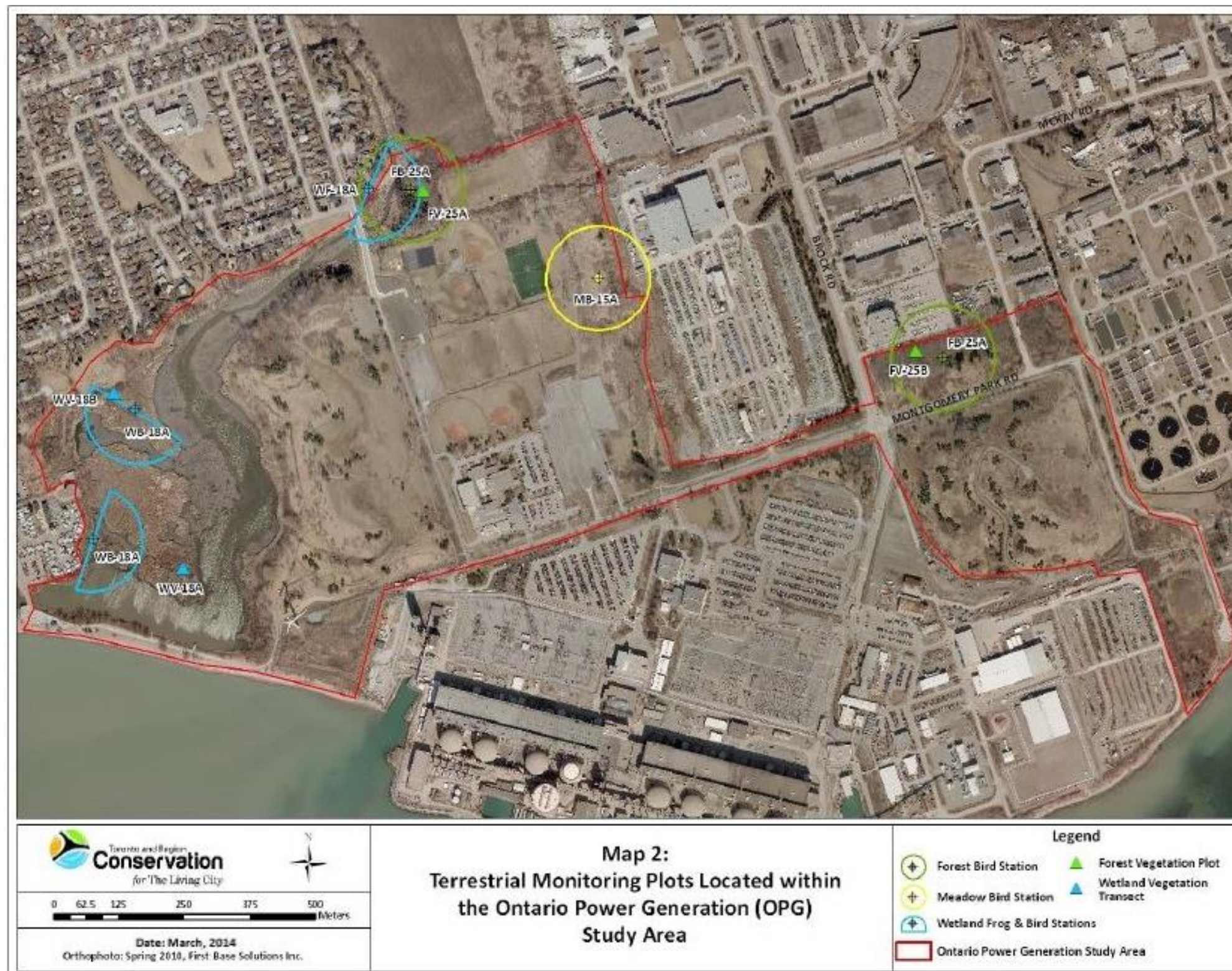

Figure 2.19: Terrestrial Monitoring Plots within the PN Site (TRCA, 2014)

2.3.5.1 Terrestrial Vegetation Communities

The terrestrial vegetation systems are upland areas where the water table is normally below the substrate surface. Four terrestrial community types were identified in the vicinity of PN, including deciduous, coniferous, and mixed forest areas, and an open beach/bar.

Forest Communities

The forest communities are small independent areas (less than 2 ha) located along Krosno Creek upstream of Hydro Marsh (Figure 2.18). They include a 1.57 ha remnant deciduous forested area at the north end of Alex Robertson Park, a 0.25 ha coniferous forest community located within the Alex Robertson Woodlot and a 1.07 ha remnant mixed forest area located just north of Kinsmen Park. The three forest communities generally consist of mature trees which form a closed canopy and result in a poorly defined shrub layer. Open canopy conditions are present in the south end of the deciduous forest community of Alex Robertson Park resulting in an abundant shrub layer. Two butternut trees (designated as a nationally endangered species (Schedule 1 SARA and Committee on the Status of Endangered Wildlife in Canada (COSEWIC)), provincially endangered by COSSARO and protected under Ontario's *Endangered Species Act*) are present along the north edge of the Mixed Forest lot north of Kinsmen Park. Plant species at risk are further discussed in Section 2.3.5.5. Designations for plant species can be updated from time to time and are current to the time of publication.

The two forest areas included in the 2009 to 2013 survey, the Kinsmen Woodlot (FV-25A) and the Brock Woodlot (FV-25B) (Figure 2.19) differ in age, structure and species composition and are fragmented and isolated from other native habitat patches (TCRA, 2014). However the overall tree health was deemed to be good.

According to TCRA (2014), the Kinsmen Woodlot is natural in origin, and supports a range of common forest species. Sugar maple (*Acer saccharum*) was the dominant tree species in the forest plot FV-25A and native choke cherry (*Prunus virginiana*) was the dominant shrub. Over the five-year period of the study, native species richness at FV-25A in the shrub layer remained relatively consistent but the prevalence of non-native species common buckthorn (*Rhamnus cathartica*), European highbush cranberry (*Viburnum opulus ssp. opulus*) and garden red currant (*Ribes rubrum*), increased to the detriment of the native species to 6% of total relative abundance and to 2.2% of total ground cover in 2013. Twenty-six species were identified in the ground layer at FV-25A which included a mix of native and non-native species. The dominant species, Virginia waterleaf (*Hydrophyllum virginianum*), garlic mustard (*Alliaria petiolata*), and yellow trout lily (*Erythronium americanum ssp. americanum*) accounted for over 90% of the ground cover. Between 2011 and 2013, the percent ground cover by native species in the ground layer showed an overall decrease from about 93% to 72% while non-native species such as garlic mustard showed an increase.

The TCRA (2014) describes the Brock Woodlot as a disturbed plantation. The plantation which was established in the 1980s has an open canopy which facilitates the growth of underlayers of vegetation. Overall the vegetation community at the Brock Woodlot is dominated by non-native species. The tree community at FV-25B consists of red ash (*Fraxinus pennsylvanica*), black locust (*Robinia pseudoacacia*), basswood (*Tilia americana*), and silver maple (*Acer saccharinum*). The dominant shrubs include wild red raspberry (*Rubus idaeus ssp. strigosus*), European highbush cranberry and chokecherry. Nineteen species were recorded in the herbaceous subplots between 2011 and 2013, of which eight were native and eleven were non-native. Eighty-nine percent of the total cover (2011-2013 average) was provided by 3 non-native species including: urban avens (*Geum urbanum*); garlic mustard (34%); and dog-strangling vine (*Cynanchum rossicum (Kleopow) Borhidi*). The latter two species have been showing an increase in cover over time at the Brock Woodlot to the detriment of native and other non-native species.

Open Beach/Bar Community

The open beach/bar is confined along the Lake Ontario shoreline, east and west of the mouth of Frenchman's Bay (Figure 2.18). This vegetation community is confined to an area near the water level that is generally subject to active shoreline processes including periodic high water levels, wave action, erosion, deposition and ice scour. The southern portions of this community, adjacent to the lake, generally support sparse vegetation cover. The vegetation cover increases in the central and northern portions of this community where wave action and ice scour occur less frequently. The structure of this vegetation community generally consists of old field vegetation and tree and shrub regeneration. The north part of the eastern bar adjacent to Hydro Marsh is protected for naturalization. A habitat restoration area has been established north of the boardwalk on the eastern bar. This area has been planted with species historically found on beaches of the Great Lakes.

Landfill Plant Community

In 2013, the TRCA conducted a flora inventory of the East Landfill located within the southeast corner of the PN site (TRCA, 2013). The landfill area consists of 17 hectares of undisturbed habitat that is fenced from any direct human disturbance. Detailed field work at the East Landfill was undertaken in 2013 to characterize the terrestrial natural heritage features of the study area. Twenty-three vegetation types were identified in the study area, including a large area of meadow, a young plantation and a poplar forest, wetland areas and successional habitats, and a small coastal strip with beach and bluff. The landfill area has been planted with almost exclusively non-native species; a total of 204 flora species were observed in 2013; including successional and wetland species. In comparison, the total study area surveyed in 2008, which occupies 113.5 hectares (TRCA, 2009a), has 288 flora species (TRCA, 2013).

2.3.5.2 Wetland Vegetation Communities

Wetland vegetation systems include areas where water levels fluctuate and are less than 2 m in depth. One swamp thicket area and five marsh areas were identified within and in the vicinity of the PN site (Figure 2.18).

The swamp thicket area is a narrow linear community located along the east margin of Hydro Marsh and forms a riparian interface between Hydro Marsh and the lower slope area of Alex Robertson Park. The vegetation is dominated by shrubs, especially speckled alder. The lower slope area of this community, where a drier soil regime is present, supports shrubs, including raspberry and elderberry, and planted trees, including silver maple and cottonwood.

The marsh communities are classified by vegetation and environmental characteristics, such as duration of flooding, substrate type, disturbance and available nutrients. Marsh communities around Frenchman's Bay, Hydro Marsh and in the West Landfill area of PN grow on organic substrates, while the marsh communities in the upper section of Krosno Creek and the eastern portion of the PN site grow on mineral materials substrates. Three of the marsh communities are classified as meadow marshes indicating that the wetland-terrestrial interface is seasonally inundated with water and usually dominated by grasses or forbes. Two marsh communities are classified as shallow marshes, indicating that the water table rarely drops below the substrate surface and the vegetation community is composed primarily of broad-leafed or narrow-leafed emergent species. The wetland communities associated with the central and western portions of Hydro Marsh and the central and northern portions of Frenchman's Bay are organic shallow marshes dominated by dense stands of broad-leaf cattail and narrow-leaf cattail. The Southeast Wetland situated at the eastern shoreline of the PN site is classified as a mineral meadow marsh ecosite. The Southeast Wetland is on a poorly drained mineral soil that receives runoff from adjacent lands from the west and north, as well as stormwater drainage through a culvert under the southern end of the Montgomery Park Road. The vegetation community is dominated by common reed, but includes pockets of dense shrub growth and sporadic tree growth.

Hydro Marsh Wetland Communities

Two wetland areas in Hydro Marsh were monitored as part of 2009 to 2013 Terrestrial Long-Term Monitoring Project study (TRCA, 2013) upstream of the eastern bar (Figure 2.19). The two wetland plots were dominated by cattail marsh. Neither supported a tree canopy. The wetland characterized by plot WV-18A covered more aquatic habitat and plot WV-18B included terrestrial shoreline habitat. The study determined that fluctuating water levels have been the main driving force in determining the presence of species across the monitored wetland communities, but overall, the floristic quality and species richness has remained stable over the study period. Although non-native species,

particularly hybrid cattail (*Typha x glauca*), were prominent in both wetlands areas, native species provided the greatest proportion of cover and species richness.

Speckled alder (*Alnus incana ssp. rugosa*), was the dominant woody plant at WV-18A and accounted for the greatest percent cover for any species, followed by the non-native species, bittersweet nightshade (*Solanum dulcamara*). Sweet gale (*Myrica gale*), a species of regional concern, was also present at WV-18A. A total of 48 species were found in the ground vegetation composition between 2009 -2013, of which 31 were native. The ground layer was dense and lush in particular along the lower half of WV-18A, and species density and diversity decreased as WV-18A extends into the open water. The species that were encountered most frequently in the coastal community included hybrid cattail, common duckweed (*Lemna minor*), purple loosestrife (*Lythrum salicaria*) and European frog-bit (*Hydrocharis morsus-ranae*).

Plot WV-18B has a sparse distribution of woody species which is dominated by native species including long-spined hawthorn (*Crataegus macracantha*) and wild red raspberry. The dominant species which composed the ground vegetation layer included hybrid cattail, common duckweed, awned sedge (*Carex atherodes*), European frog-bit and orange touch-me-not (*Impatiens capensis*).

2.3.5.3 Open Water Vegetation Community

Open water vegetation communities are generally aquatic communities in which the permanent water is generally deeper than 2 m and the total vegetation cover is greater than 25%. An open water vegetation community occupies the majority of Frenchman's Bay and the main channel associated with the lower reaches of Krosno Creek and Hydro Marsh. In Hydro Marsh, most of the open water is less than 0.5 m deep and substrates in the upstream areas can be exposed depending on the water level in Lake Ontario. Aquatic vegetation is sparse and is limited to isolated pockets of floating duckweed species.

2.3.5.4 Cultural Vegetation Communities

Cultural vegetation communities originate from, or are maintained by anthropogenic influences and culturally based disturbances. They often contain a large proportion of non-native species. In addition to large areas of mown parkland located in the Alex Robertson Park and the Kinsmen Park, three cultural community types were identified within or in the vicinity of the PN site, including a cultural plantation, a cultural meadows and cultural thicket (Figure 2.18 and Figure 2.19).

The 2.3 ha forested area located north of Montgomery Park Road and east of Brock Road, the Brock Woodlot, is a disturbed plantation which TCRA (2014) classifies as a Silver Maple Deciduous Plantation. The woodlot consists of rows of silver maple, white ash, black locust and eastern cottonwood, oriented in an east-west direction.

Cultural meadows are open vegetation communities that support less than 25% tree cover and less than 25% shrub cover. These communities develop in areas that have not been subjected to mowing practices and typically represent an early stage of natural succession. This vegetation type is the most common community type at the PN site. Cultural meadow vegetation occurs throughout the East and West Landfill Sites, adjacent to the Southeast Wetland, along portions of the hydro corridor, along the south side of the Brock Woodlot and in areas of Alex Robertson Park that have been allowed to naturalize (Figure 2.18 and Figure 2.19).

Cultural thickets are characterized by tree cover less than 10% and tall shrub cover greater than 25%. These communities represent a more advanced state of natural regeneration than cultural meadow areas. Within the PN site, cultural thicket vegetation is most predominant along the east side of the hydro corridor. These communities consist of old field meadow species and thicket vegetation that has been allowed to naturalize for some time. Shrubs are densely arranged in most areas, and openings within the thicket vegetation is dominated by herbaceous species typical of cultural meadow communities.

2.3.5.5 Vegetation Species at Risk

A list of the plant species that have been recorded at the PN site, along with their regional federal and provincial species at risk status ranking, is provided in Golder (2007c) and OPG (2016a). The list includes observations from the 2011 to 2015 inventories as well as earlier referenced observations for the area. Four plant species (Table 2.13) with a status of threatened or endangered were recorded at the PN site.

Table 2.13: Plant Species at Risk Observed within the PN Site Area (OPG, 2016a; TRCA, 2014)

Scientific Name	Common Name	Federal Species at Risk Status	Provincial Ranking	Most Recent Year Observed
<i>Juglans cinerea</i>	Butternut	Endangered	Endangered	2013
<i>Lespedeza virginica</i>	Slender bush-clover	Endangered	Endangered	2000
<i>Gymnocladus dioicus</i>	Kentucky coffee-tree	Threatened	Threatened	2000
<i>Morus rubra</i>	Red mulberry	Endangered	Endangered	2000

Note:

The Provincial Species at Risk in Ontario List, Federal List of Wildlife Species at Risk (Schedule 1 of the Species at Risk Act (SARA)), and COSEWIC list are frequently revised.

Butternut was identified in TRCA (2009) as being located in the Fresh-Moist Sugar Maple – Hemlock Mixed Forest environmental land classification (ELC), and was most recently identified in 2013 in Kinsmen Park. The other plant species at risk identified in Table 2.13 have not been observed since 2000.

2.3.5.6 Wildlife Habitat

Wildlife habitat is associated with the vegetation communities and natural and developed areas found within. This section summarizes the potential use of different vegetation communities by wildlife species that have been recorded at the PN site.

2.3.5.6.1 Wildlife Habitats and Terrestrial Wildlife Species Lists

Detailed description of wildlife communities and species recorded at the PN site and their use of the different habitats is provided in Golder (2007c). Documentation of wildlife communities and species derived from historical records, wildlife mortality survey work conducted for the Pickering A Return to Service Environmental Assessment and associated follow-up and monitoring undertaken from 2004 to 2006 were reviewed (Golder, 2007c). These documents reported three amphibian species, seven reptile species, 247 bird species and 23 mammal species occurring within or in the vicinity of the PN site.

The big brown bat (*Eptesicus fuscus*), red bat (*Lasiurus borealis*) and hoary bat (*Lasiurus cinereus*) were last observed on the PN site in 2002 (OPG, 2002a). Based on site observations on May 20, 2015 by an ecologist, bat habitat is not apparent on the PN site as most of the buildings would not provide suitable bat habitat. Suitable bat habitat was apparent in the woodlots adjacent to the PN site, although no bats were observed.

The presence of birds was documented as part of the 2009 to 2013 Terrestrial Long-Term Monitoring Project study (TRCA, 2014) and as part of the 2015 monitoring season (TCRA, 2015). Most of the bird species observed were considered to be secure in the urban landscape of the greater Toronto region. The results of species observed for each area (forest, wetland and meadow) are listed in Table 2.14 and summarized in this section.

Table 2.14: Bird Species Observed During the 2009 to 2015 Terrestrial Long Term Monitoring Project

Species		Habitat		
Scientific Name	Common Name	Wetlands	Meadow	Forest
Wetland Species				
<i>Branta canadensis</i>	Canada Goose	√	-	√
<i>Gallinula chloropus</i>	Common Moorhen	√	-	-
<i>Geothlypis trichas</i>	Common Yellowthroat	√	√	-
<i>Anas strepera</i>	Gadwall	√	-	-
<i>Ixobrychus exilis</i>	Least Bittern	√	-	-
<i>Anas platyrhynchos</i>	Mallard	√	-	-
<i>Porzana carolina</i>	Sora	√	-	-
<i>Melospiza georgiana</i>	Swamp Sparrow	√	-	√
<i>Rallus limicola</i>	Virginia Rail	√	-	-

Species		Habitat		
Scientific Name	Common Name	Wetlands	Meadow	Forest
<i>Cistothorus palustris</i>	Marsh Wren	√	-	-
Meadow Species				
<i>Tyrannus tyrannus</i>	Eastern Kingbird	√	√	√
<i>Actitis macularius</i>	Spotted Sandpiper	√	-	-
<i>Empidonax traillii</i>	Willow Flycatcher	√	√	-
Forest Species				
<i>Poliotilta caerulea</i>	Blue-grey Gnatcatcher	-	-	√
<i>Myiarchus crinitus</i>	Great-crested Flycatcher	-	-	√
<i>Contopus virens</i>	Eastern Wood-pewee	-	-	√
<i>Vireo olivaceus</i>	Red-eyed Vireo	-	-	√
<i>Setophaga ruticilla</i>	American Redstart	-	-	√
<i>Picoides pubescens</i>	Downy Woodpecker	-	-	√
<i>Melospiza melodia</i>	Song Sparrow	√	√	√
<i>Poecile atricapillus</i>	Black-capped Chickadee	-	-	√
<i>Quiscalus quiscula</i>	Common Grackle	√	-	√
<i>Dumetella carolinensis</i>	Grey Catbird	√	√	√
<i>Cardinalis cardinalis</i>	Northern Cardinal	√	-	√
<i>Agelaius phoeniceus</i>	Red-winged Blackbird	√	√	√
<i>Sitta carolinensis</i>	White-breasted Nuthatch			√
<i>Pheucticus ludovicianus</i>	Rose-breasted Grosbeak		√	
Generalist Species				
<i>Setophaga petechia</i>	Yellow Warbler	√	√	√
<i>Spinus tristis</i>	American Goldfinch	-	√	√
<i>Turdus migratorius</i>	American Robin	-	√	√
<i>Bombcilla cedrorum</i>	Cedar Waxwing	-	√	√
<i>Zenaidura macroura</i>	Mourning Dove	-	√	√
<i>Mimus polyglottos</i>	Northern Mockingbird	-	√	-
<i>Icterus galbula</i>	Baltimore Oriole	√	√	√
<i>Cyanocitta cristata</i>	Blue Jay	-	-	√
<i>Colaptes auratus</i>	Northern Flicker	-	-	√
<i>Icterus spurius</i>	Orchard Oriole	-	√	-
<i>Buteo jamaicensis</i>	Red-tailed Hawk	-	√	-
<i>Vireo gilvus</i>	Warbling Vireo	-	-	√
<i>Molothrus ater</i>	Brown-headed Cowbird*	-	√	√

Species		Habitat		
Scientific Name	Common Name	Wetlands	Meadow	Forest
<i>Sturnus vulgaris</i>	Eurasian Starling			√
<i>Passer domesticus</i>	House Sparrow			√

Notes:

√ indicates that the species was observed

- Indicates that the species was not observed

* brown-headed cowbird is a brood parasite, i.e. does not nest

source: TRCA, 2014; 2015

Wetlands

Marsh and swamp habitat is found both in Frenchman’s Bay Marsh and Hydro Marsh and extends to a limited degree in Krosno Creek upstream of Sandy Beach Road. A small marsh habitat also occurs in the naturalized area to the south of East Landfill (referred to as the southeast wetland) and along the south edge of the West Landfill. Frenchman’s Bay and Hydro Marsh contain a large area of open shallow water surrounded by a cattail perimeter. The open water portion of the marsh does not contain emergent vegetation so this portion is used primarily by gulls, ducks, geese and swans for limited foraging for items such as insects, while the perimeter areas are used by a variety of bird species for nesting and foraging. Birds that may use the perimeter areas include Red-winged Blackbird and Black-crowned Night Heron. The open water and perimeter areas are used by aquatic mammals, such as muskrat, amphibians (American Toad, Green Frog and Northern Leopard Frog) and reptiles (Snapping Turtle, Midland Painted Turtle, Northern Map Turtle, Blanding’s Turtle, Red-eared Slider, Eastern Garter Snake, Dekay’s Brownsnake).

During the 2009 to 2013 study, a total of 20 bird species were identified at two wetland bird stations in Hydro Marsh (TRCA, 2014). As shown in Table 2.14, 10 of the 20 bird species were wetland associated species, three were meadow associated species and the rest were generalist species.

Six frog species have been observed in wetlands in the vicinity of the PN site, including at Hydro Marsh, Frenchman’s Bay and Durham Marsh between 2007 and 2014. These include Northern Leopard Frog, Gray Treefrog, Spring Peeper, American Toad, Green Frog, and Chorus Frog. Also during the 2009 to 2013 study, three frog species, American Toad, Green Frog and Leopard Frog, were observed, but at very low numbers. The American Toad and Green Frog were also observed during the 2015 site species inventory (OPG, 2016c).

Woodland

Woodland refers to a treed community having 35% to 60% cover by coniferous or deciduous trees. Woodland habitat within the PN site is generally limited to the Brock Woodlot and Alex Robertson Woodlot, as well as the wooded area along the east edge of Krosno Creek. Woodland habitat is used for nesting foraging and roosting by resident and migratory bird species. Small mammals will also use these sites for shelter, foraging and reproduction.

As shown in Table 2.14, a total of 28 bird species were identified at two forest bird stations at the PN site during the 2009 to 2013 study (TRCA, 2014) and during the 2015 monitoring event (OPG, 2015). The majority of the species observed, fifteen, were woodland or generalist species. The presence of two wetland and one meadow species in the forest bird count was attributed to the areas in which the bird counts were completed, which overlapped wetland or meadow areas because of the relatively small size of the forest area.

Shrubland

Shrubland habitat occurs at the edge of the woodland habitat areas and in areas where trees and shrubs have been permitted to grow at coverage percentages <35% to 60%. Shrubland habitat is located at the south edge of the Brock Woodlot and along the west side of Alex Robertson Community Park adjacent to the Hydro Marsh and its woodland areas. Shrubland habitat also occurs in the beach/bar, Alder Mineral Thicket Swamp, Broad-leaved Sedge Mineral Meadow Marsh, Mineral Meadow Marsh Ecosite and the Sumac Cultural Thicket communities show on Figure 2.18. This transitional habitat between field and forest is used by a combination of field and woodland bird species that prefer dense shrub cover for nesting and foraging and by small mammals for shelter, foraging and reproduction.

Open Grassland

Open grassland includes those open areas that are either natural or seeded and then left in a relatively natural state. Open grassland habitat is available in the cultural meadow vegetation of the East and West Landfills, adjacent to the Southeast Wetland, along portions of the hydro corridor, along the south side of the Brock Woodlot and in areas of Alex Robertson Park that have been allowed to naturalize. Open grassland can provide habitat for species that prefer grassland and prairies. It will be used by birds for nesting, foraging and shelter, and small mammals for shelter, foraging and reproduction.

One meadow station (MB-15A) was set up during the 2009 to 2013 study (Figure 2.19). During the 2009 to 2013 study, a total of 205 bird species were identified at two forest bird stations at the PN site. The meadow station was dominated by species that do not have any specific association with meadow-habitat (Table 2.14), and would likely persist at the site even if the meadow habitat were to succeed to shrub habitat and then to early successional forest (TRCA, 2014).

Parkland

Parkland is those habitats that are managed for recreational or aesthetic purposes. Parkland habitat includes portions of Kinsmen Park, Alex Robertson Community Park, and the various areas of maintained lawn. While habitat is limited in this area due to the lack of vegetation cover and diversity, certain species, such as swallows, nighthawks, swifts and bats, will make use of the open area to forage.

Shoreline and Open Water Habitat

Shoreline habitat consists of the Open Beach/Bar community shown in Figure 2.18. This area provides a small amount of habitat for loafing and foraging by waterbirds, particularly wading birds and geese. The open water portions of the PN site are also used by waterbirds for resting and foraging, and provide feeding opportunities for resident species such as ducks, gulls, terns and swans.

Pickering Nuclear Built Environment

The PN site includes buildings and man-made structures that provide habitat for wildlife. Buildings provide habitat suitable for common urban bird species and rodents that are tolerant of noise and activity associated with the daily operations of the station. Habitat conditions within the envelope of the generating station buildings are typically marginal due to the lack of cover, shelter and food. The taller buildings and their auxiliary structures provide opportunity for raptors, such as Peregrine Falcon, and other species to scan for food sources and provides roosting opportunities for other species such as doves and sparrows. The Black-crowned Night Heron, which is classified as a vulnerable species in the province, is commonly observed roosting on cables across the PN U5-8 discharge channel. Several of the buildings on the PN site may provide a suitable habitat for the Barn Swallow. Much of the PN built environment occurs within fenced areas, restricting the movement of larger mammals within this area; however, white-tailed deer and red fox are occasionally recorded within the fenced areas. Red fox den sites are located within the fenced area. The constructed shoreline, where the station meets Lake Ontario, consists of large areas of armourstone. These areas provide loafing opportunities for gulls and small mammals that inhabit rock crevices and small vegetated areas that have opportunistically grown up along the shoreline.

The PN intake forebay and PN discharge channels provide both loafing and foraging habitat for a variety of waterbird species. These areas remain ice-free throughout the winter and offer shelter from Lake Ontario during inclement weather.

2.3.5.6.2 Terrestrial Animal Species at Risk

Terrestrial animal species at risk have been recorded at the PN site (OPG, 2016a; TRCA, 2009; 2014), along with their federal and provincial ranking updated to January 20, 2016, and are presented in Table 2.15. The list includes observations from the 2009 to 2013

TRCA inventories, and OPG inventories up to 2015, as well as earlier referenced observations for the area. OPG inventories include incidental observation, migrants and residents and therefore species listed in Table 2.15 are not necessarily breeding within the PN site. Three reptile species, eleven bird species and one insect species at risk (Table 2.15) with a provincial ranking of threatened or special concern were recorded at the PN site.

Table 2.15: Terrestrial Animal Species at Risk Observed within the PN Site (OPG, 2016a)

Scientific Name	Common Name	Federal Species at Risk Status	Provincial Ranking	Most Recent Year Observed
Amphibians and Reptiles				
<i>Chelydra serpentina</i>	Snapping Turtle	Special Concern	Special Concern	2009
<i>Emydoidea blandingii</i>	Blanding's Turtle	Endangered	Threatened	2006
<i>Graptemys geographica</i>	Northern Map Turtle	Special Concern	Special Concern	2006
Birds				
<i>Chaetura pelagica</i>	Chimney Swift	Threatened	Threatened	2008
<i>Chlidonias niger</i>	Black Tern	-	Special Concern	2008
<i>Chordeiles minor</i>	Common Nighthawk	Threatened	Special Concern	2010
<i>Dolichonyx oryzivorus</i>	Bobolink	Threatened	Threatened	2006
<i>Falco peregrinus</i>	Peregrine Falcon	Special Concern	Special Concern	2015
<i>Haliaeetus leucocephalus</i>	Bald Eagle	-	Special Concern	2007
<i>Hirundo rustica</i>	Barn Swallow	Threatened	Threatened	2015
<i>Riparia riparia</i>	Bank Swallow	Threatened	Threatened	2008
<i>Contopus virens</i>	Eastern Wood Pewee	Special Concern	Special Concern	2015
<i>Ixobrychus exilis</i>	Least Bittern	Threatened	Threatened	2013
<i>Podiceps auritus</i>	Horned Grebe	Special Concern	Special Concern	2015
Insects				
<i>Danaus plexippus</i>	Monarch	Special Concern	Special Concern	2011

Notes:

The Provincial Species at Risk in Ontario List, Federal List of Wildlife Species at Risk (Schedule 1 of the Species at Risk Act (SARA)), and COSEWIC list are frequently revised.

2.3.6 Aquatic Communities

This section describes existing aquatic communities focusing on the SSA and LSA (Figure 2.20 and Figure 2.21), as these two areas encompass the larger area in which direct effects of the PN site may be measurable. The RSA, which encompasses areas of Lake Ontario outside of the LSA, is discussed in terms of regional fish and invertebrate populations that migrate into the SSA and LSA. More detailed descriptions of site, local and regional aquatic environments and the aquatic communities therein are provided in Golder (2007b).

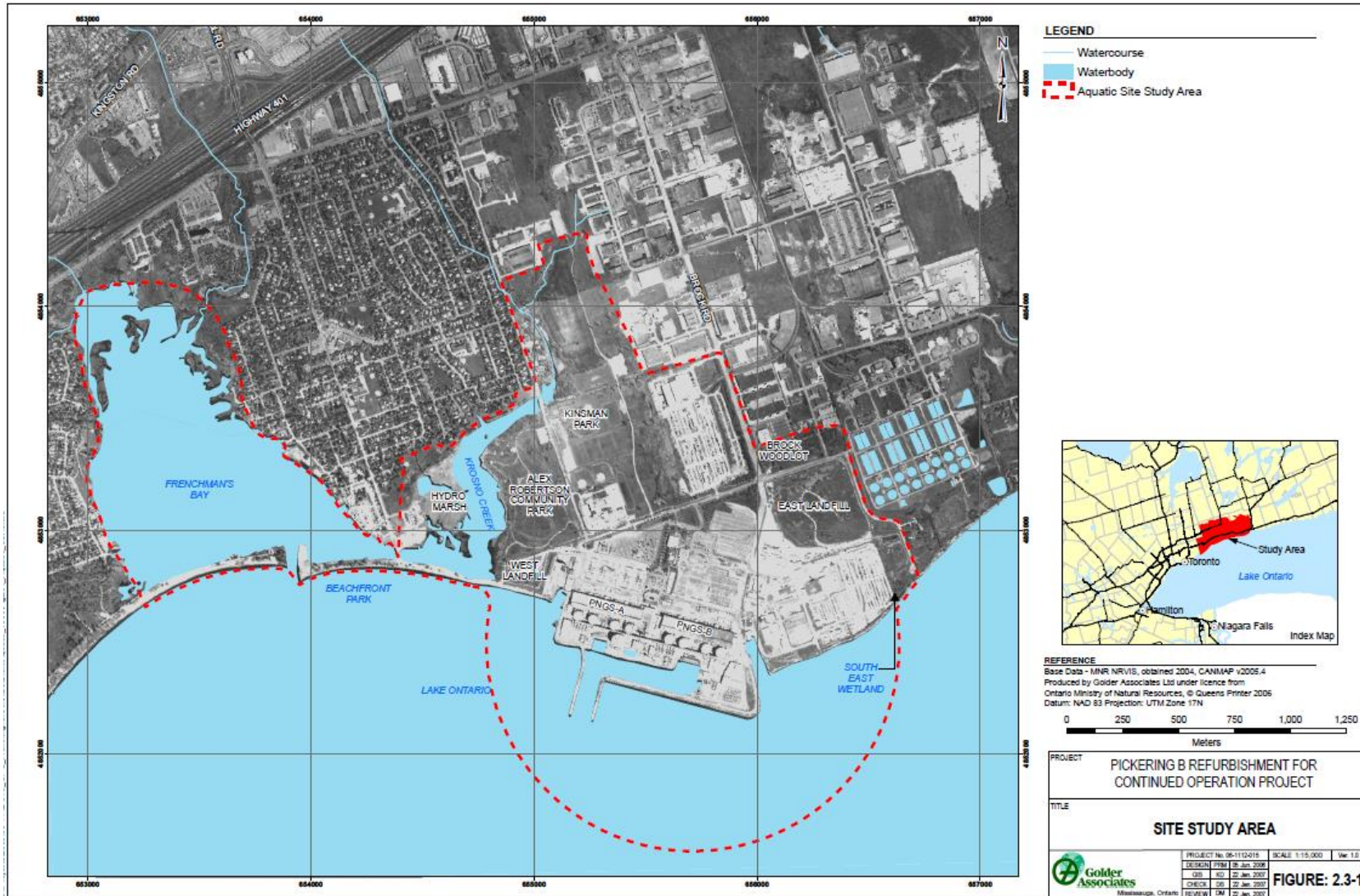

Figure 2.20: Aquatic Site Study Area (Golder, 2007b)

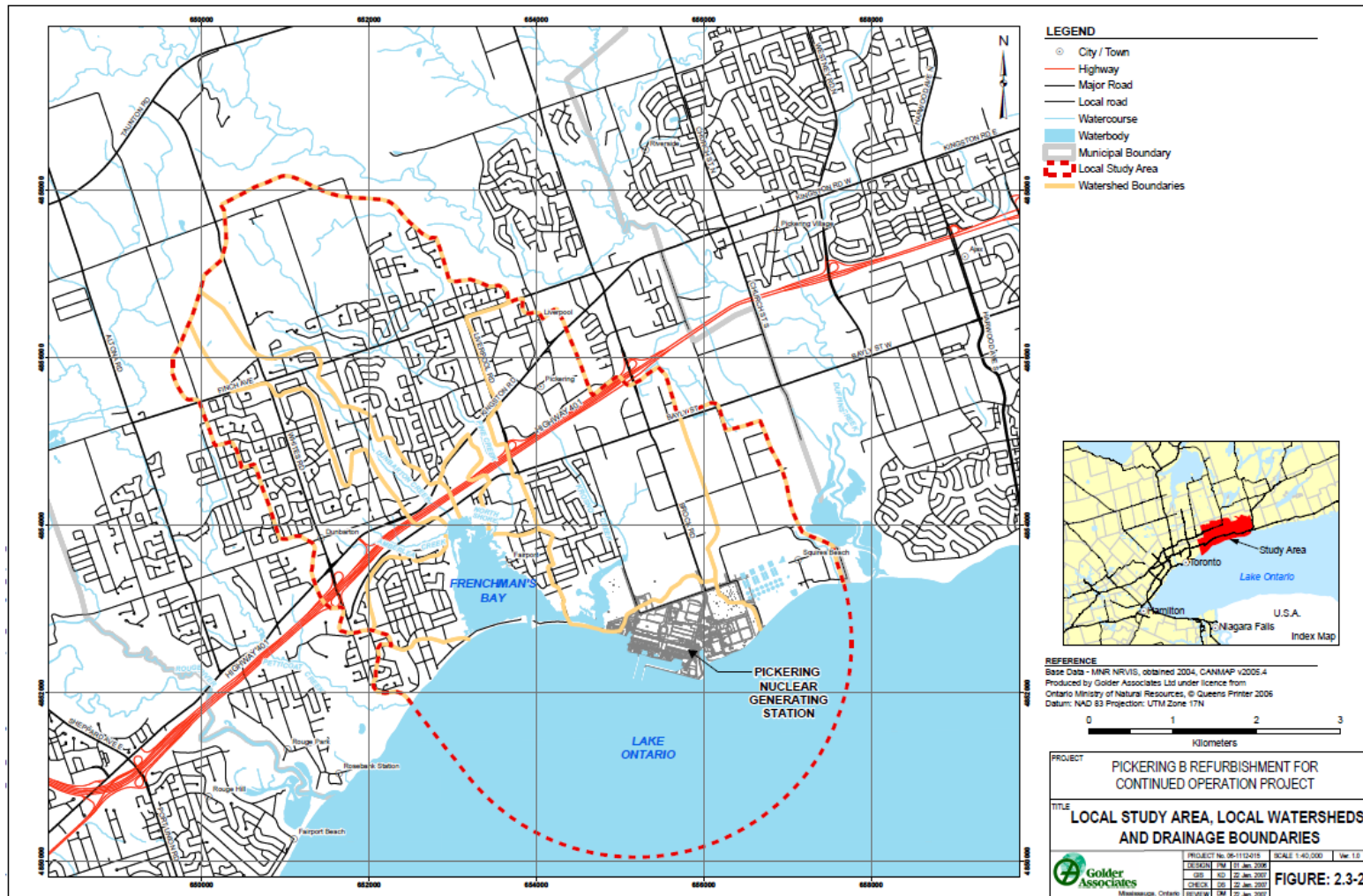

Figure 2.21: Aquatic Local Study Area (Golder, 2007b)

2.3.6.1 Periphyton, Phytoplankton and Zooplankton Communities

Plankton communities in the vicinity of the PN site are highly variable and have undergone significant changes over the past 30 years that are not related to PN site activities. For example, changes to nutrient loadings, fluctuating populations of pelagic planktivores, colonization by the filter feeding zebra mussel and introduction of exotic zooplankton predators have altered the plankton community structure of Lake Ontario. Therefore, the use of historical information, prior to the mid-1970s, in describing current conditions may be of limited use based on the ecosystem changes in Lake Ontario.

Since the 1970s, phytoplankton biomass has declined in Lake Ontario presumably due to phosphorus reduction programs and the colonization of zebra mussels (Environment Canada *et al.*, 1998). Diatoms dominate the overall phytoplankton community in diversity and biomass. In summer, during stable stratified conditions, phytoplankton communities in Lake Ontario shift away from diatoms to include substantial contributions to biomass by chlorophytes, cyanophytes and dinoflagellates (Barbiero and Tuchman, 2001). Decreases in the densities of several major algal groups, including diatoms, chlorophytes and cryptophytes, have contributed to the overall decrease in algal density observed in nearshore algal communities along the northshore of Lake Ontario (Winter *et al.*, 2012).

The zooplankton community in Lake Ontario is dominated by a small number of species and the current community composition appears to have been stable since the 1960s (Barbiero *et al.*, 2001, Lampman, 1999). The total crustacean densities and species richness are generally higher during the summer than in the spring. Structuring of the zooplankton community is affected by the intense planktivory particularly by alewives. Dominant zooplankton groups include crustaceans, primarily cyclopod copepods, along with cladocerans, *Bosmina* and *Daphnia* (Barbiero *et al.*, 2001).

Periphyton is benthic algal material. The periphyton community near PN are dominated by the filamentous algae *Cladophora glomerata* that grows attached to solid substrata and forms dense growths that are periodically detached by waves and wash ashore. *Cladophora* growth is limited by availability of phosphorous and light penetration (substratum availability). Phosphorous reduction programs in Lake Ontario initially resulted in a reduction in *Cladophora* productivity. However, habitat availability for *Cladophora* and overall productivity have increased since the 1990s, due to reduced algal growth and colonization of the lake by filter feeding zebra and quagga mussels which have reduced water turbidity and offset reductions (Higgins *et al.*, 2008, Auer *et al.*, 2010).

2.3.6.2 Benthic Invertebrates

The benthic community of the north shore of Lake Ontario is characteristic of the unstable, relatively severe conditions typical of the exposed coast. Small crustaceans (especially the benthic amphipod, *Diporeia* spp.) and worms (oligochaetes) have historically dominated the open water benthic communities of Lake Ontario. Benthic community studies conducted

from 1976 to 1978, indicated that the community was dominated by oligochaetes and chironomids, and contained significant numbers of amphipods, molluscs and ostracods (Lush 1981, cited in Golder 2007b). Representatives of the more environmentally sensitive groups such as Ephemeroptera and Trichoptera were rare. Most of the dominant taxa had higher abundances at sites within or close to the PN U1-4 thermal plume than at reference sites. Diversity was generally higher in the spring/fall than in the summer/winter seasons. The diversity of the invertebrate community at sites with a depth of 6 and 10 m were influenced by the thermal plume and diversity was significantly lower than for the reference sites. This observation was attributed to an increase in the relative abundance of certain species and not to a reduction in species numbers. No differences in diversity were noted at the 1 m sites, presumably due to the exposed conditions that masked plume effects. Gastropods and bivalves had low relative abundances due to wave abrasion and/or unsuitable substrates at shallow locations. Appearance of chironomid, amphipod and oligochaete increased in the vicinity of the discharge channels (1 m sites) where the alga, *Cladophora*, was present.

More recently, zebra mussels and quagga mussels have colonized the nearshore areas in the vicinity of PN and are now very abundant. Benthic organisms which have possibly been negatively affected by zebra and quagga mussels' colonization in nearshore areas of the lake include *Diporeia* spp., oligochaetes, sphaerid clams, and unionid clams (Golder, 2007b).

The aquatic macroinvertebrate community in Durham Region wetlands was studied as part of a 6-year coastal wetland monitoring project (EC, 2009a). Data for fifteen Durham Region coastal wetlands, collected between 2002 and 2007, were compiled and biotic communities were compared. Wetlands at or in the vicinity of the PN site that were included in the study included Hydro Marsh, Frenchman's Bay and Duffins Creek Marsh. The study used Indices of Biological Integrity (IBI) to assess and compare wetland conditions. The IBI values for macroinvertebrate communities were derived using measures for richness (number of Ephemeroptera and Trichoptera genera and total number of families), and relative abundance (percent crustacea and mollusca, percent tricoptera, and percent diptera). Over the study period, most Durham Region coastal wetlands were on average in "good" or "fair" condition. Hydro Marsh was notable as "poor", Frenchman's Bay Marsh was "fair" and Duffins Creek Marsh was "good" (EC, 2009b). Overall, macroinvertebrate communities in Durham Region were considered to be in poorer condition relative to other Lake Ontario wetlands.

2.3.6.3 Fisheries

More than 90 species of fish are known to inhabit Lake Ontario. Almost all of these species make use of nearshore waters of the lake for spawning, rearing, feeding, and migrations. Many of these species rely on habitats contained within coastal marshes, embayments and estuaries. Examples of these habitats within the SSA and LSA include Hydro Marsh, Frenchman's Bay and the Mouths of the Rouge River and Duffins Creek.

Fish species at risk that have been recorded at the PN site, along with their federal and provincial ranking, are listed in OPG (2016a). The list includes observations from the 2009 to 2015 inventories as well as earlier referenced observations for the area. Three fish species at risk (Table 2.16) with a provincial or federal ranking of threatened, endangered or extinct were recorded at the PN site. Atlantic Salmon were observed within the area as recently as 2010. The Atlantic Salmon Lake Ontario Population is listed as extinct federally and provincially. Atlantic Salmon found in Lake Ontario are likely individuals from the Atlantic Salmon stocking program and are not considered individuals of the native Lake Ontario Population. Impingement monitoring in 2013 identified Silver Shiner and Spotted Gar which are both provincially ranked as threatened, and under SARA Schedule 1 are ranked as of special concern and threatened, respectively. However, these species are not resident or migratory fish species of Lake Ontario; they are typically associated with creeks and streams rather than large lakes. The presence of these species in impingement samples is considered questionable. As such, Silver Shiner and Spotted Gar have not been listed in Table 2.16.

Table 2.16: Fish Species at Risk Observed within the PN Site Area (OPG, 2016a)

Scientific Name	Common Name	Federal Species at Risk Status	Provincial Ranking	Most Recent Year Observed
Fish				
<i>Acipenser fulvescens</i>	Lake Sturgeon	Threatened	Threatened	2005
<i>Anguilla rostrata</i>	American Eel	Threatened	Endangered	2015
<i>Salmo salar</i>	Atlantic Salmon *	Extinct	Extinct	2015

Notes:

The Provincial Species at Risk in Ontario List, Federal List of Wildlife Species at Risk, Schedule I and COSEWIC list are frequently revised.

* Atlantic Salmon (Lake Ontario Population) is listed as extinct. Atlantic salmon found in Lake Ontario are likely individuals from the Atlantic Salmon stocking program and are not considered to represent a native Lake Ontario Population.

The fish community may be divided into resident and migratory species. Migratory species are only seasonally present in the Lake Ontario nearshore, these include pelagic fishes such as Rainbow Smelt, Alewife and Brown Trout which make seasonal spawning migrations into the nearshore zone, including entering the discharge channels and the intake forebay of PN (when FDS is not present); and inshore fishes which occupy coastal marshes and river mouth habitats and enter the nearshore zone when water temperature and velocity conditions are favourable. In the case of the discharge channels, the warmer discharge water provides unique opportunities for fish and invertebrates, resulting in concentrated foraging opportunities. Table 2.17 lists resident and migratory fish species which have been observed within the site and local study areas.

Table 2.17: Common and Scientific Names of Resident and Migratory Fish Species at PN (Golder, 2007b)

Resident Fish Species		Migratory Fish Species	
Common Name	Scientific Name	Common Name	Scientific Name
Longnose Gar	<i>Lepisosteus osseus</i>	Sea Lamprey	<i>Petromyzon marinus</i>
Bowfin	<i>Amia calva</i>	Lake Sturgeon	<i>Acipenser fulvescens</i>
American Eel	<i>Anguilla rostrata</i>	Alewife	<i>Alosa pseudoharengus</i>
Gizzard Shad	<i>Dorosoma cepedianum</i>	Lake Chub	<i>Couesius plumbeus</i>
Goldfish	<i>Carassius auratus</i>	Emerald Shiner	<i>Notropis atherinoides</i>
Common Carp	<i>Cyprinus carpio</i>	Spottail Shiner	<i>N. hudsonius</i>
Common Shiner	<i>Luxilus cornutus</i>	Longnose Sucker	<i>Catostomus catostomus</i>
Golden Shiner	<i>Notemigonus crysoleucas</i>	White Sucker	<i>C. Commersoni</i>
Mimic Shiner	<i>N. Volucellus</i>	Redhorse Sucker	<i>moxostoma spp.</i>
Bluntnose Minnow	<i>Pimephales notatus</i>	Rainbow Smelt	<i>Osmerus mordax</i>
Fathead Minnow	<i>P. promelas</i>	Lake Herring (Cisco)	<i>Coregonus artedi</i>
Longnose Dace	<i>Rhinizchethys cataractae</i>	Lake Whitefish	<i>C. clupeaformis</i>
Quillback	<i>Carpiodes cyprinus</i>	Pink Salmon	<i>Oncorhynchus gorbuscha</i>
Black Bullhead	<i>Ameiurus melas</i>	Coho Salmon	<i>O. kisutch</i>
Brown Bullhead	<i>A. nebulosus</i>	Rainbow Trout	<i>O. mykiss</i>
Channel Catfish	<i>Ictalurus punctatus</i>	Chinook Salmon	<i>O. tshawytscha</i>
Stonecat	<i>Noturus flavus</i>	Round Whitefish	<i>Prosopium cylindraceum</i>
Northern Pike	<i>Esox lucius</i>	Atlantic Salmon	<i>Salmo salar</i>
Trout-perch	<i>Percopsis omiscomaycus</i>	Brown Trout	<i>Salmo trutta</i>
Brook Silverside	<i>Labidesthes sicculus</i>	Brook Trout	<i>Salvelinus fontinalis</i>
Brook Stickleback	<i>Culaea inconstans</i>	Splake	<i>S. fontinalis X S. namaycush</i>
White Perch	<i>Morone americana</i>	Lake Trout	<i>S. namaycush</i>
White Bass	<i>M. chrysops</i>	Threespine Stickleback	<i>Gasterosteus aculeatus</i>
Rock Bass	<i>Ambloplites rupestris</i>	Mooneye	<i>Hiodon tergisus</i>
Pumpkinseed	<i>Lepomis gibbosus</i>	Round Goby	<i>Neogobius melanostomus</i>
Bluegill	<i>L. macrochirus</i>		
Smallmouth Bass	<i>Micropterus dolomieu</i>		
Largemouth Bass	<i>M. salmoides</i>		
White Crappie	<i>Pomoxis annularis</i>		
Black Crappie	<i>P. nigromaculatus</i>		
Johnny Darter	<i>Etheostoma nigrum</i>		
Yellow Perch	<i>Perca flavescens</i>		
Logperch	<i>Percina caprodes</i>		
Walleye	<i>Sander vitreus</i>		

Resident Fish Species		Migratory Fish Species	
Common Name	Scientific Name	Common Name	Scientific Name
Freshwater Drum	<i>Aplodinotus grunniens</i>		
Slimy Sculpin	<i>Cotius cognatus</i>		
Mottled Sculpin	<i>C. bairdi</i>		

Notes:

Data derived from LGL Limited, 1992; Toronto and Region Conservation Authority, 1999; Golder Associates, 2000, as cited in Golder, 2007b.

Fish species in bold font have been identified during impingement monitoring for PN for the 5-year period from 2011 to 2015 (OPG, 2016b, 2015c, 2014, 2013e, 2012h).

Spawning and Rearing Habitats

On a local level, the exposed shoreline of Lake Ontario provides rocky substrates for lake trout and Round Whitefish spawning in the shallow nearshore waters east of PN. Both east and west of PN, the Lake Ontario nearshore areas support broadcast spawning by Emerald Shiner. Juvenile habitat for Lake Trout, Round Whitefish and Emerald Shiner exist both east and west of PN as well. The Rouge River mouth and Duffins Creek contains spawning and juvenile habitats for Northern Pike, Smallmouth Bass and Emerald Shiner and juvenile habitat for White Sucker. Frenchman's Bay may provide spawning and juvenile habitat for Smallmouth Bass, Northern Pike, White Sucker and Emerald Shiner.

Spawning habitat for Smallmouth Bass, Northern Pike and Emerald Shiner exists within the SSA. Smallmouth Bass spawning and nest-building occur within the PN discharge channels. The shoreline is a high energy habitat, due to the effects of Lake Ontario wave action and fish species are not likely to use it as spawning habitat with the possible exception of Emerald Shiner. Northern Pike and Emerald Shiner may use Hydro Marsh as spawning habitat. The SSA also provides rearing habitats for immature stages of some species, such as Smallmouth Bass (PN discharge channels, the armoured shoreline, and Hydro Marsh), Round Whitefish (PN U1-4 discharge channel and the armoured shoreline), White Sucker (PN discharge channels) and Emerald Shiner (the armoured shoreline).

An exploratory Round Whitefish spawning population assessment project was conducted at three locations (Pickering, Darlington and Peter Rock) along the north central shoreline of Lake Ontario during late November and early December, 2014 (Ontario MNRF, 2015). Round Whitefish were collected from each location with the objective to obtain detailed biological attribute information from the spawning population of fish. The Round Whitefish ranged from 3 to 26 years of age. Fifty-five percent of the fish caught were male. Gonad condition indicated that the netting dates in late November and early December, bracketed peak spawning time for round whitefish.

As part of this work, Round Whitefish collected during spawning at the three locations were subjected to genetic analysis to determine whether local meta-populations are discernable. This would be relevant to interpretation of potential effects on Round Whitefish at the population level. The studies have not produced any evidence for discrete meta-

populations among Round Whitefish from the different sampling locations. Instead, the studies supported the presence of a single panmictic population of Round Whitefish in Lake Ontario (Ontario MNRF, 2016a).

Foraging Habitats

Foraging opportunities may be seasonal and dependant on local conditions. For example, Lake Trout can only forage in the nearshore zone when colder water temperatures exist due to the season or to wind-driven upwellings of colder lake water. Coldwater species such as Lake Trout and Round Whitefish, winter in Lake Ontario and are not likely to feed within the river mouth and marsh habitats. Warm and coolwater species such as Smallmouth Bass, Northern Pike, Walleye, White Sucker and Emerald Shiner, likely use the mouth of the Rouge River, Duffins Creek rivermouth/ marsh habitat, and Frenchman's Bay as foraging habitat.

Each of the habitats within the SSA provide foraging habitats for at least some fish species. Piscivores, such as Smallmouth Bass, Northern Pike, Walleye and Lake Trout have been observed in the intake forebay and may feed on schools of baitfish. Round Whitefish and White Sucker may feed on bottom dwelling invertebrates associated with aquatic vegetation and the variety of substrates found within the forebay. The armoured shoreline may provide foraging habitat for many fish species including Northern Pike, Walleye and Lake Trout which are attracted to schools of small planktonivorous fishes such as the emerald shiner that are common in the shallows along the breakwalls. Smallmouth Bass may use the protective cover and foraging opportunities provided in the spaces among the armour, and White Sucker and Round Whitefish may feed on benthic invertebrates in the shallow water adjacent to the armoured shoreline.

Impingement monitoring for the 5-year period from 2011 to 2015 identified 52 species of fish which may occupy the intake forebay (OPG, 2016b, 2015c, 2014, 2013e, 2012h). Of these species, the most commonly impinged fish species are Alewife, Gizzard Shad, Round Goby, Three-Spine Stickleback, Emerald Shiner, and Rainbow Smelt. Entrainment and impingement effects are discussed in Section 4.4.4.

Forty-six of the fish species identified during impingement monitoring from 2011 to 2015 are included in Table 2.17 (as shown in bold font). The remaining six species identified during impingement monitoring are not typically considered to be resident or migratory fish species of Lake Ontario. Five of the six species were identified only once during the monthly monitoring events over the 5-year period (American Brook Lamprey, Creek Chub, Silver Shiner, Spotted Gar and Burbot). Of these, Burbot are known to inhabit Lake Ontario although the population is kept low due to predation by Sea Lamprey and Alewives. Silver Shiner and Spotted Gar are both provincially ranked as threatened, under SARA Schedule 1 are ranked as of special concern and threatened, and under COSEWIC are ranked as threatened and endangered, respectively. However, these species are typically associated

with creeks and streams rather than large lakes such as Lake Ontario. Round Goby, an invasive species in Ontario waters, was identified in all impingement studies.

Migration and Overwinterings

Walleye, Lake Trout, Round Whitefish, White Sucker and Emerald Shiner may follow the shoreline on regional or local migrations to and from deeper water. Smallmouth Bass and Northern Pike are more closely associated with coastal marshes and embayments but may migrate between those habitats by following the Lake Ontario shoreline. Migrations into Duffins Creek mouth may include spawning runs of Northern Pike, and White Sucker in the spring and Brown Trout and introduced Atlantic Salmon in the fall, movements between protected warmwater habitats, seasonal foraging movements and movements in response to wind-driven water temperature changes. Smallmouth Bass, Northern Pike, White Sucker and Emerald Shiner migrate into, between or among the sheltered warmwater habitats along the shores of Lake Ontario, including the Duffins Creek mouth.

Winter habitats for Walleye, Lake Trout, Round Whitefish, White Sucker and Emerald Shiner are found in the nearshore waters of Lake Ontario in the LSA. White Suckers are tolerant of a wide range of water temperatures and are year-round inhabitants of the nearshore zone, and Lake Trout and Round Whitefish occupy nearshore areas when temperatures permit, throughout the year. Overwintering habitats may exist in Duffins Creek for Smallmouth Bass, Northern Pike and Emerald Shiner and in Frenchman's Bay for Smallmouth Bass, Northern Pike, Walleye, White Sucker and Emerald Shiner. Walleye and White Sucker may also migrate to Duffins Creek during the winter. Walleye are attracted by the thermal plume(s) during winter. Smallmouth Bass and Northern Pike are more likely to overwinter within coastal marshes and, possibly, in the PN discharge and intake channels. Emerald Shiner makes an offshore shift with the onset of winter, but is present in the nearshore zone at other times of the year.

2.3.7 Human Land Use

Aspects of regional, local and site human land uses have been presented in the Pickering B Refurbishment EA (SENES, 2007e) and the Human Health TSD (SENES, 2007b). In this section, current land uses, agricultural production, water supply and recreational fishing are summarized.

2.3.7.1 Review of Durham Region and City of Pickering Land Use

PN is located in the Region of Durham, City of Pickering, on the north shore of Lake Ontario. It is approximately 21 km west southwest of Oshawa and approximately 32 km east of downtown Toronto. The Region of Durham and the City of Pickering have both urban and rural land uses. In general, the urban uses in the Region of Durham parallel the shoreline of Lake Ontario in the communities of Pickering, Ajax, Whitby, Oshawa and Clarington. The rural uses are in the northern portion of the municipality in the communities of Brock, Scugog and Uxbridge. The urban land uses in the City of Pickering, including

residential, commercial and employment, are generally located south of 3rd Concession along Lake Ontario. The rural uses, including agricultural uses and rural hamlets, are generally located north of 3rd Concession.

PN is part of the Brock Industrial Neighbourhood, in the City of Pickering, immediately east of the Bay Bridges Neighbourhood, south of Highway 401, west of the Town of Ajax and north of Lake Ontario. The land use surrounding PN is largely urban, including industrial, residential and parkland. Duffins Creek Water Pollution Control Plant is located to the east of the PN site, and several marinas are located to the west of the PN site along Lake Ontario. Frenchman's Bay and Hydro Marsh (class 2 wetlands) are located approximately 1.5 km to the west and Duffins Creek Marsh (class 3 wetland/ environmentally significant area/ area of natural and scientific interest) is located approximately 2.5 km to the east.

PN is approximately 240 ha in size with a continuous landscaped buffer paralleling all adjacent municipal roads. PN is fenced and access is restricted and controlled by OPG. There is a 914 m exclusion zone around PN. This exclusion zone limits the type of uses that can occur within its confines. The exclusion zone is predominantly owned by OPG. These lands are primarily used for industrial purposes related to electricity generation. Two public outdoor recreation parks, Alex Robertson Community Park and Kinsmen Park, are located approximately 600 m northwest of PN U1-4, on lands leased by the City of Pickering.

OPG has made significant biodiversity improvements at Alex Robertson Park since 2000, including planting more than 14,000 trees and shrubs along with 1,800 native wildflowers.

2.3.7.2 Agricultural Production

An inventory of Ontario agricultural data was completed for the 2012 Pickering Nuclear Radiological Environmental Monitoring Program (OPG, 2013b) site specific survey using data from the 2011 Census of Agriculture conducted by Statistics Canada. The total area of land used for fruits, vegetables and potatoes in Ontario was estimated at 80,444 ha (804 km²). Of that, 24.6% is used for fruit production, 56.6% is used for vegetable production and 18.8% is used for potato production. Assuming that agricultural production is uniform across Ontario, the total land used for fruit, vegetable and potato production within a 30 km radius semi-circle centered at PN was estimated to be 348 km², 800 km² and 266 km², respectively. Fruit, vegetable and potatoes production from within the 30 km radius semi-circle was estimated to be 4.1×10^8 kg, 2.1×10^9 kg and 5.1×10^8 kg, respectively.

In 2012, there were six commercial dairy farms operating within 20 km of the PNGS (OPG, 2013b).

2.3.7.3 Water Supply

Water supplies from four municipal water supply plants (WSP) are included in the PN EMP: the Ajax and Whitby WSPs situated east of PN, and J.F. Horgan and R.C. Harris WSPs situated southwest of PN. The water intake for the Ajax WSP located approximately 6.5 km east of the PN site is the nearest to of the four WSPs to the PN site. All four WSPs obtain their water from Lake Ontario. The water supply for the City of Pickering and the Town of Ajax is provided primarily from the Ajax WSP which services a population of almost 200,000. The more rural areas of Durham are supplied by individual water supply systems from either surface water intakes or ground water wells. The F.J. Horgan WSP services Scarborough and sells water to the York Region. The R.C. Harris WSP services eastern and central Toronto and also sells water to the York Region.

Table 2.18 summarizes the offshore distance and depth of the WSP intakes, WSP capacities, populations served and distance of the intakes from the PN site for each of the PN EMP WSPs, recommended for use in public dose calculations (OPG, 2013b).

Table 2.18: Water Supply Plant Information (OPG, 2013b)

	Distance of Intake from Shore (m)	Intake Depth (m)	Capacity (m ³ /day)	Population Served	Estimated Distance of Intakes from PN (km)
R.C. Harris WSP	2,300	15	950,000	1,500,000	21.7 km SW
F.J. Horgan WSP	3,200	9	800,000	2,000,000	11.3 km SW
Ajax WSP	2,500	13.5	163,500	198,025	6.5 km E
Whitby WSP	1,710	15	118,000	121,455	12.3 km ENE

Note:

Ajax WSP's intake pipe is at a depth of 18 m, however the water is drawn in from an intake crib that is 13.5 m below the lake surface.

2.3.7.4 Recreational Fishing

Recreational fishing near the PN property is popular among local residents, but is not a widespread activity among people living in the study area. Results from a recreational fisheries survey undertaken by OPG in the fall of 1999 indicated that most recreation fishing activity nearest the PN property was shore angling rather than boat angling (SENES, 2007e). Of the shore angling sites, Frenchman's Bay was the most popular. At PN, smallmouth bass is targeted the most. At Frenchman's Bay salmon and trout were most commonly targeted but largemouth bass and common carp were most commonly caught. At the Rouge River, west of the PN site, the most prevalent catch was common carp.

2.3.8 Population Distribution

Since 2004, Durham's population increased from 562,573 to a projected population of 653,567 at the end of 2014 (DRHD, 2015). Population growth was highest in Durham

Region among seniors 85 years and older and populations actually decreased among children ages 5 to 14 years and among adults 35 to 44 years. Overall population growth in Durham region between 2004 and 2014 was highest in Ajax (34%) and Whitby (23%), and smallest in Pickering with an increase of 4% (DRHD, 2015).

The majority of residents in Durham region live in urban areas. Over 90% of the population in Pickering, Ajax, Oshawa and Whitby reside in urban areas, whereas, the townships of Brock, Scugog and Uxbridge represent the greatest percentage of the rural population in Durham. Urban/rural population trends for Durham indicate this trend will continue into 2031 (DRPD, 2015).

Based on Ontario Population Estimates for 1986-2014, Durham's population distribution clearly depicts the Boom (45 to 59 year range), Bust (25 to 39 year range), and Echo (15 to 25 year range) generations (DRHD, 2015). Children under the age of 15 comprised 17.3% of the population in 2014, while young persons (aged 15-24), adults (aged 25-64) and older adults (aged 65+) comprised 14.4%, 54.9% and 13.4%, respectively (DRPD, 2009). Ontario Population Estimates for 1986-2014 (DRHD, 2015) indicate that the 50 to 54 age group is the largest age group for both males and females in Ontario and in Durham Region.

The most recent census data for the region are for 2011. A population of approximately 2.2 million reside within a 30 km radius of the PN site, based on 2011 census data shown in Table 2.19 (OPG, 2013b). The bulk of this population (approximately 80% or 1.8 million) resides west of the PN site, in the southwest to north-north-west sectors, while approximately 20% (0.4 million) reside east of the PN site in the north to east-north-east sectors. Areas south and east of the PN site (south-south-west to east) are occupied by Lake Ontario. Approximately 0.2% of this population (3,359) reside within a 0 to 2 km radius of the PN site, 11% of this population (243,281) reside within a 0 to 10 km radius, and 26% (564,820 individuals) reside within a 0 to 16 km radius of the PN site.

Table 2.19: Population Distribution Surrounding PN Based on 2011 Census Data (OPG, 2013b)

Direction	N	NNE	NE	ENE	E	ESE	SE	SSE	S	SSW	SW	WSW	W	WNW	NW	NNW	Total
0-2 km	5	5	0	0	0	0	0	0	0	0	0	0	560	940	1,793	56	3,359
2-4 km	10	0	2,690	1,496	0	0	0	0	0	0	0	2,355	4,503	4,121	6,352	4,012	25,539
4-6 km	8,143	5,483	11,665	3,232	0	0	0	0	0	0	2,385	3,915	9,353	13,235	10,731	10,725	78,867
6-8 km	22,512	11,928	9,679	1,064	0	0	0	0	0	0	10,810	9,655	7,221	4,500	453	3,816	81,638
8-10 km	16,709	4,844	414	54	0	0	0	0	0	0	6,465	24,334	630	296	90	42	53,878
10-12 km	4,637	5,829	11,062	0	0	0	0	0	0	0	19,941	18,523	8,482	74	211	40	68,799
12-14 km	462	14,553	13,993	0	0	0	0	0	0	0	21,984	38,925	23,650	928	134	354	114,983
14-16 km	196	18,722	18,849	56	0	0	0	0	0	0	35,872	36,617	15,693	11,514	97	141	137,757
16-22 km	1,847	34,072	98,426	11,353	0	0	0	0	0	0	138,004	184,391	145,949	78,161	965	1,643	694,811
22-30 km	1,957	4,593	66,172	1,302	0	0	0	0	0	0	388,842	300,412	140,683	11,202	26,097	1,729	942,989
Total	56,478	100,029	232,950	18,557	0	0	0	0	0	0	624,303	619,127	356,724	124,971	46,923	22,558	2,202,620

3.0 HUMAN HEALTH RISK ASSESSMENT

3.1 Problem Formulation

3.1.1 Receptor Selection and Characterization

3.1.1.1 Receptor Selection

Human receptors are defined as on-site workers, contractors and visitors, as well as off-site members of the public.

3.1.1.1.1 On-site Non-Nuclear Energy Workers

On-site workers, contractors, and visitors are potentially exposed to environmental contaminants, both chemical and radiological, but these exposures are considered and controlled through the Health and Safety Management System Program and the Radiation Protection Program, and are not considered in the HHRA, as discussed below.

The Health and Safety Management System Program is designed to ensure the protection of employees, contractors and visiting members of the public. The program outlines a systems approach used to manage risks associated with activities, products and services of OPG Nuclear operations. Contractors are required to maintain a level of safety equivalent to OPG staff while working at an OPG workplace. Work at OPG is subject to safe work planning requirements where safety hazards are identified and mitigating measures are communicated through Pre-Job Briefings. Routine or planned work is governed by approved procedures and operating instructions (OPG, OPG-PROG-0010).

The Radiation Protection Program is designed to ensure that doses for employees, contractors and visiting members of the public are below regulatory limits, and As Low As Reasonably Achievable, social and economic factors being taken into account (ALARA). Employee radiation doses are monitored to ensure they do not exceed exposure control levels that are below regulatory limits. Doses to visitors and contractors are also monitored. Only workers classified as Nuclear Energy Workers (NEWs) may perform radioactive work. Visitors are limited to non-radioactive work and escorted by a qualified NEW. Personal information is collected for the purposes of dose reporting (OPG, N-PROG-RA-0013 R007).

Because human exposures on the site are kept within safe levels through the Health and Safety Management System Program and Radiation Protection Program, on-site receptors are not addressed further in the HHRA. The focus of the HHRA is on off-site members of the public.

3.1.1.1.2 Members of the Public

Off-site members of the public are potentially exposed to low levels of airborne or waterborne contaminants. The potentially most affected off-site members of the public are

defined as “critical groups”. Critical groups are defined through the site specific survey and used for dose calculations in the OPG Annual Environmental Monitoring Programs (EMP) Reports. The most recent site specific survey was completed in 2012 (OPG, 2013b), and concludes that the six potential critical groups identified in the 2006 site specific survey are still appropriate; however, the 2012 survey provides some updated critical group characteristics. The six potential critical groups are:

- C2 Correctional Institution
- Local Urban Residents
- Local Farms
- Local Dairy Farms
- Sport Fishers
- Off-site Industrial/Commercial Workers

These six critical groups are used for the exposure assessment for both radiological and non-radiological COPCs.

3.1.1.2 Receptor Characterization

The critical group receptor characteristics used for exposure assessment are described in Appendix E of the 2014 EMP Report (OPG, 2015a) and are presented below.

- The **C2** potential critical group consists of inhabitants at a correctional institute, located approximately 3 km NNE of the PN site. The C2 group obtains drinking water from the Ajax WSP and does not consume locally produced fruits or vegetables. The C2 resident is conservatively assumed to be at this location 100 percent of the time over at least one year.
- The **Industrial/Commercial** potential critical group consists of adult workers whose work location is close to the nuclear site. Members of this group are typically at this location about 23% of the time. They consume water from the Ajax WSP. The closest location for this group is about 1 km NNE of the site.
- The **Urban Residents** potential critical group consists of Pickering and Ajax area residents which surround the PN site (e.g., Fairport, Fairport Beach, Rosebank, Liverpool, Pickering Village, etc.). The members of this group mostly consume water from the Ajax WSP and also consume a diet composed in part of locally grown produce and an insignificant component of locally caught fish. Members of this potential critical group are also externally exposed to beach sand at local beaches (Beachpoint Promenade, Liverpool Rd. Beach or Squires Beach).
- The **Farm** potential critical group consists of residents of agricultural farms (but not dairy farms) within a 10 km radius of the PN site. Members of this group obtain most of their water supply from wells but also a portion from the Ajax WSP. Members of this potential critical group consume locally grown produce and animal products.

They are also externally exposed to beach sand at local beaches (Beachpoint Promenade, Liverpool Rd. Beach or Squires Beach).

- The **Dairy Farm** potential critical group consists of residents of dairy farms within a 20 km radius of the PN site. This group obtains most of their water supply from local wells. They also consume locally grown fruit and vegetables and locally produced animal products, including fresh cow's milk. Members of this potential critical group are also externally exposed to beach sand at local beaches (Beachpoint Promenade, Liverpool Rd. Beach or Squires Beach).
- The **Sport Fisher** potential critical group is comprised of non-commercial individuals fishing near the PN site outfalls, 0.5 km S of the PN site. Members of this group were conservatively assumed to obtain their entire amount of fish for consumption from the vicinity of the PN site and spend 1% of their time at the outfall location where atmospheric exposure occurs.

The receptors that are closest to the facility are the Sport Fisher, the Urban Resident, and the Industrial/Commercial Worker. Within each critical group three different age classes are defined: 0-5 years (infant), 6-15 years (child), and 16-70 years (adult), consistent with CSA N288.1-08 (CSA, 2008). Site-specific receptor data were used for the exposure assessment, where available. Otherwise, default receptor characteristics such as body weight, inhalation rates, ingestion rates etc. were obtained from sources as outlined in CSA N288.6-12. The radiological HHRA presents doses already reported in EMP reports from 2011 to 2015, using site-specific data from the 2006 site-specific survey (OPG, 2006a). For the non-radiological HHRA, site-specific data from the 2012 site-specific survey were used (OPG, 2013b).

As recommended by CSA N288.6-12, human health radiological risk assessments should follow the guidance of CSA N288.1-08. With the exception of the drinking water intake rate for the 1 year old infant, the intake rates are the mean intake rates from CSA N288.1-08. As discussed in OPG (2010b), the drinking water intake rate for a 1 year old infant is 0 kg/a since the 1 year old is assumed to only drink cow's milk; as recommended in CSA N288.1-08.

3.1.2 Selection of Chemical, Radiological, and Other Stressors

The PN facility emits chemical and radiological contaminants to air and water in the normal course of operations. Measurements and modeled concentrations of these contaminants in air and water taken from 2011 to the end of 2015 were screened against available screening benchmarks that are protective of human health to determine if any contaminants of potential concern (COPCs) required further study in the context of human health risk assessment. Where no data were available during the 2011 to 2015 period, older data were used. The potential for screening for COPCs in other environmental media is also discussed below.

3.1.2.1 Chemical COPCs in Air

The main sources of atmospheric emissions result from boiler chemical emissions and fuel combustion. Boiler treatment chemicals including hydrazine, morpholine and degradation products are used within the feedwater system to prevent corrosion in the boilers. These chemicals are released to the atmosphere through controlled boiler venting. Combustion emissions result from the Standby Gas Turbines, Auxiliary Power System Combustion Turbine Units, Auxiliary Power System Diesel Generators and minor sources. These systems release carbon monoxide, nitrogen oxides, sulphur dioxide, suspended particulate matter, trace volatile organic compounds, and polycyclic aromatic hydrocarbons (PAHs).

The Air ECAs from 2011 to 2015, the 2011 ESDM Report (and 2014 Appendix E Emergency Equipment Assessment update), and the 2015 ESDM Report, prepared to support the application for an ECA were assessed to aid in COPC selection (Golder, 2011; OPG, 2015e). The emergency equipment assessment was outside of the main body of the ESDM Report, consistent with MOE guidance with respect to assessing nitrogen oxides emissions for emergency equipment. The air dispersion modelling results for nitrogen dioxides from the emergency generator assessment showed that under all scenarios in the assessment the maximum predicted concentration remained below the ½ hour Ontario Ministry of Environment and Climate Change (MOECC) point-of-impingement (POI) limit of 500 µg/m³.

The main body of the ESDM report presents the estimated atmospheric emissions of COPCs from the PN site (Golder, 2011, 2015). The ESDM uses dispersion modelling to predict the maximum concentration at the property line POI for each COPC, by using a dispersion factor of 9.9755 µg/m³ at the property line for each 1 g/s emission of a contaminant (Golder, 2011). In the ESDM, a preliminary screening is performed to identify negligible sources and negligible contaminants using Section 7 criteria in the MOE's Procedure for Preparing an ESDM Report (MOE, 2009a). Examples of methods used in the ESDM to screen out negligible contaminants include using emission thresholds or de minimus concentrations. Significant sources and contaminants are identified in Table 1 of the ESDM (OPG, 2015e) and are the focus of the secondary screening presented in this ERA and discussed below.

The ½ hour POI concentrations were first compared against ½ hour MOECC POI limits, where available. Where such criteria were not available, COPCs were screened against jurisdictional screening levels (JSLs). Comparison against the ½-hour POI standards is appropriate as these limits are generally set at a factor of 15 times greater than the annual Ambient Air Quality Criteria (AAQC), based on MOECC's conversion equation between averaging periods (MOE, 2009a).

For seven substances without POI limits or JSLs, annual concentrations were estimated from the ½ hour POI concentrations using the MOE averaging conversion equation, and compared against compound-specific long-term effects screening limits (ESLs) obtained

from the Texas Commission on Environmental Quality (TCEQ, 2015). Long-term ESLs are appropriate for annual averaging periods and are based on data for health effects, odour, and effects on vegetation.

No modelled exceedances were observed from 2011 to 2015, as shown in Appendix A (Table A.1). The 2015 ESDM presents updated predictions for hydrazine based on MOECC request. Modelling for hydrazine is discussed in the next section.

3.1.2.1.1 Results from 2015 Hydrazine Modelling

Hydrazine does not have a POI limit or JSL. The MOECC requested that OPG assess the annual hydrazine concentrations using the US EPA AERMOD dispersion model. Only long-term average exposure is relevant to the cancer endpoint. The main source of hydrazine emissions is from steam venting during unit start-up. In addition, small fugitive losses of steam occur continuously from the steam generator relief valves, feedwater heaters, reheater safety valve vents, silencer vents, powerhouse heating steam vents, feedwater heating relief valve vents, turbine and piping atmospheric drain tank vents, and poison prevent piping vents. Hydrazine, ammonia and morpholine are added to the steam generators to prevent corrosion within the system. Worst case hydrazine emissions ($1.87\text{E-}03$ g/s) were modelled during different operating conditions/scenarios (i.e., normal operating condition and unit start-ups) to predict annual hydrazine concentrations at a number of receptors along the property (OPG, 2015e). Based on the updated AERMOD modelling, the 2015 ESDM reports the highest annual average residential hydrazine concentration of $1.8\text{E-}04$ $\mu\text{g}/\text{m}^3$, at the most sensitive receptor location (Parkham Crescent Resident – R1, as shown in Figure 3.1). However, based on all locations assessed in AERMOD, the maximum annual average hydrazine concentration was $6.9\text{E-}04$ $\mu\text{g}/\text{m}^3$, at a location along the modelled south property boundary, as shown in Figure 3.1. The south property boundary is in the general vicinity of the Sport Fisher.

Since there is no POI limit or JSL for hydrazine, the maximum annual average concentration of hydrazine was compared to the U.S. EPA IRIS Lifetime Risk (1 in 1 million) level of $2.0\text{E-}04$ $\mu\text{g}/\text{m}^3$ for continuous lifetime exposure (i.e., residential areas). Based on the AERMOD modelling, the maximum annual average hydrazine concentration at the south property border ($6.9\text{E-}04$ $\mu\text{g}/\text{m}^3$) exceeded the lifetime risk level. As such, hydrazine was carried forward as a COPC requiring further assessment for human health.

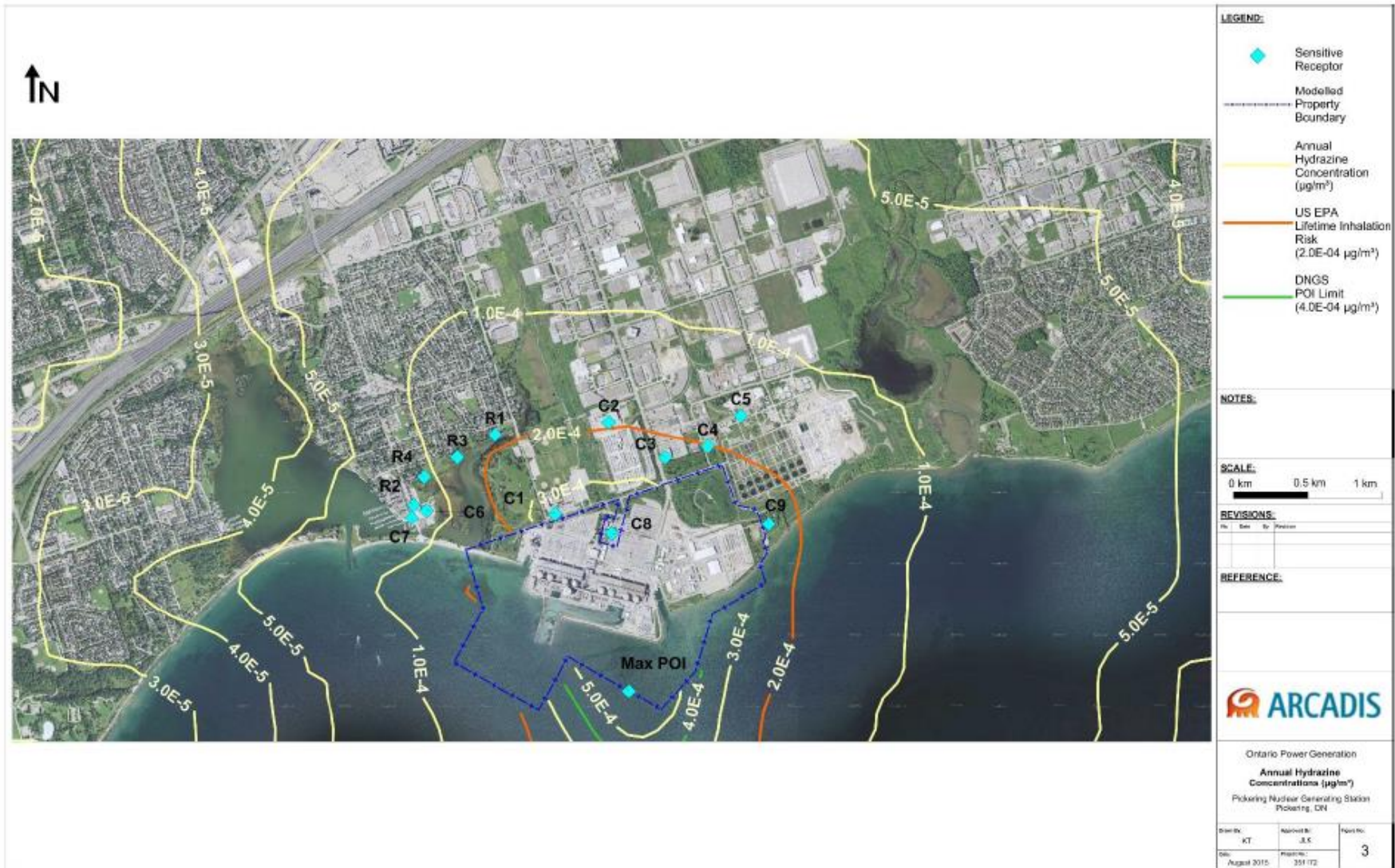

Figure 3.1: Modelled Annual Hydrazine Atmospheric Concentration at Locations around the PN Site (OPG, 2015e)

3.1.2.2 Chemical COPCs in Surface Water

The surface water screening is based on measurements of COPCs discharged from 2011 to 2015 into the CCW discharge channel, as well as lake water measurements collected in 2014 and 2015. The screening based on effluent discharge is presented in Section 3.1.2.2.1. The screening based on lake water measurements is presented in Section 3.1.2.2.2.

3.1.2.2.1 Liquid Effluent

Information from 2011 to 2015 on the concentration of COPCs discharged in liquid effluents into the environment was available from PN ECA reports, MISA reports, and National Pollution Release Inventory reports. This information was assessed to aid in COPC selection.

As shown in Figure 2.5, all effluent except for sewage and stormwater is released into the outfall. As such, the final station discharge released from the CCW discharge duct was assessed as the compliance point. As part of the ECA requirements, the effluent is sampled and analyzed for unionized ammonia, hydrazine, morpholine, pH, and total residual chlorine (TRC). For each COPC, the maximum concentration in the effluent from 2011 to 2015 was screened against its provincial water quality objective (PWQO), Canadian Council of Ministers of the Environment (CCME) water quality guideline, or a federal or provincial drinking water quality guideline. Drinking water guidelines were used as the preferred screening levels, where available, as they are more relevant to human health than the PWQO or CCME water quality guidelines.

Hydrazine does not have a PWQO or a CCME water quality guideline, or a drinking water quality guideline. However, the U.S. Environmental Protection Agency (US EPA) estimated that a hydrazine concentration of 0.01 µg/L would result in a cancer risk level of 1E-06 (EC/HC, 2011), based on a drinking water intake rate of 2 L/day and no amortization. This calculated concentration is used as a screening level for hydrazine in water. As shown in Table A.2 in Appendix A, the maximum concentration for hydrazine has exceeded the screening level (0.01 µg/L); therefore, hydrazine has been carried forward for further quantitative assessment in the HHRA.

As shown in Table A.2 in Appendix A, the maximum concentration for morpholine has exceeded the PWQO (0.004 mg/L) during the 2011 to 2015 period. Although the PWQO is not based on human health protection, there is no human health based screening level for morpholine. In 2015 there were two instances where the maximum morpholine concentration (0.082 mg/L in March, 0.036 mg/L in April) exceeded the ECA limit of 0.02 mg/L; however, these elevated concentrations were not supported by PN's morpholine usage and discharges during the sampling periods. OPG indicated that the elevated concentrations were likely related to contamination during sampling or analysis (OPG,

2016e). In 2011 the reported maximum morpholine concentration from PN U5-8 was 0.168 mg/L. This number was later retracted since it was determined through a third-party review that the elevated concentrations were suspect and due to mislabeling or sample contamination during analysis (OPG, 2012e). Irrespective of this particular event, there were still instances where the morpholine concentration at the final discharge exceeded the PWQO. Since there is uncertainty regarding the PWQO being protective of human health, and since there are instances where the PWQO for morpholine was exceeded, morpholine has been carried forward for further quantitative assessment in the HHRA.

Although total residual chlorine exceeded the PWQO (0.002 mg/L) during the 2011 to 2015 period, it does not exceed the Health Canada drinking water range of 0.04 to 2.0 mg/L. Although Health Canada has not set a drinking water limit, at these concentrations, taste and odour related to chlorine or its by-products are generally within the range of acceptability for most consumers (Health Canada, 2009). The WHO reports that at a residual chlorine concentration of 0.6 mg/L some sensitive individuals could have an aversion to the taste. The WHO has set a drinking water limit for chlorine of 5 mg/L, based on a 1992 study by the US National Toxicology Program on rodents; however, no adverse health effects were observed (WHO, 2011). Based on the above discussion, total residual chlorine has not been carried forward for further quantitative assessment in the HHRA.

Effluent monitoring is required under the MISA program, as described in Section 2.2.2.1.6. As part of the MISA program, COPCs for monitoring are identified for the RLWMS effluent NWTP neutralization sumps, and the combined effluent of PN U1-4 and U5-8 (Table 2.4). Many of the COPCs monitored in the RLWMS and NWTP are not monitored again in the outfall.

For MISA monitoring parameters measured in the RLWMS and NWTP (phosphorus, TSS, zinc, iron, oil and grease, and aluminum), Golder (2007a) conducted mixing calculations to obtain expected concentrations of COPCs in the CCW based on effluent discharge to the CCW from the RLWMS and the NWTP. Mixing calculations were based on a worst case scenario, assuming effluent was discharged at the MISA limits. This is conservative, since exceedances of MISA limits have not been observed for the majority of the COPCs over the past 14 years (2001- 2015). Mixing calculations have been updated based on a CCW flow rate for PN U5-8 of 116 m³/s (Golder, 2007a) and assumes two CCW pumps per unit operating.

Since none of the MISA monitoring parameters (except for pH) for the RLWMS are measured in the CCW duct after mixing, mixing calculations for the RLWMS discharge to the CCW duct were calculated based on the maximum concentrations of the RLWMS discharge allowed under MISA. The calculated CCW concentrations were compared against the PWQOs and were found to be well below these limits. The concentration in the CCW was calculated according to the following equation:

$$\text{Conc. in CCW} = \frac{\text{Conc. in RLWMS effluent} \bullet \text{Effl. flow rate} + \text{Intake Conc.} \bullet \text{CCW flow rate}}{\text{CCW flow rate}}$$

The maximum RLWMS discharge flow rate was assumed to be 0.0126 m³/s and the CCW flow rate was assumed to be 116 m³/s (Golder, 2007a).

For the NWTP discharge to the CCW, the concentration in the CCW was calculated according to the following equation:

$$\text{Conc. in CCW} = \frac{\text{Conc. in NWTP effluent} \bullet \text{Effl. flow rate} + \text{Intake Conc.} \bullet \text{CCW flow rate}}{\text{CCW flow rate}}$$

The maximum NWTP discharge flow rate was assumed to be 0.02 m³/s and the CCW flow rate was assumed to be 116 m³/s (Golder, 2007a). The calculated CCW concentrations were compared against the PWQOs and were found to be well below these limits.

Based on MISA reports from 2011 to 2015, no exceedances of MISA limits have been observed. Therefore based on mixing calculations, no PWQO exceedances in the CCW are expected for the MISA parameters, as shown in Table 3.1.

Table 3.1: Summary of CCW Mixing Calculations for RLWMS and NWTP

Parameter	Units	Intake Conc. (Golder, 2007a)	MISA Limit at Effluent Discharge	Max Conc. in CCW	PWQO
RLWMS A, B					
Phosphorus	mg/L	<0.01	1	<0.01	0.02
Total suspended solids	mg/L	<2	73	<2	N/A
Zinc	mg/L	0.01	1	0.010	0.03
Iron	mg/L	0.025	9	0.026	0.3
Oil and Grease	mg/L	<1	36	<1	Narrative
NWTP					
Aluminum	mg/L	0.004	13	0.0056	0.075
Total suspended solids	mg/L	<2	70	<2	N/A
Iron	mg/L	0.0025	2.5	0.0253	0.3

3.1.2.2.2 Lake Water Sampling

The 2014 ERA (EcoMetrix, 2014) evaluated lake water data from 2006 and carried forward hydrazine and morpholine to the quantitative analysis in the HHRA. As part of the updated

baseline environmental program, recent lake water data in the vicinity of the PN site were collected in summer of 2015 to quantify the concentration of COPCs in the PN outfalls. The lake water results are summarized in Appendix A, Table A.3.

Water quality samples were collected from five locations (see Table 3.2 and Figure 3.2) in the vicinity of the PN outfalls, and one control location near Cobourg WSP. Samples were analyzed for alkalinity, ammonia (total and un-ionized), biochemical oxygen demand (BOD), chemical oxygen demand (COD), hardness, pH, conductivity, temperature, total suspended solids (TSS), total residual chlorine (in-situ), petroleum hydrocarbons (PHC F1 to F4), morpholine, metals, and radionuclides.

In 2014, an EMP supplementary study for hydrazine in surface water was conducted (EcoMetrix, 2015). The objective was to obtain hydrazine surface water results at a low detection limit of 0.05 µg/L. In previous studies, the detection limit for hydrazine in lake water samples was 5 µg/L, higher than levels corresponding to 1E-05 and 1E-06 cancer risk. In 2014, samples were collected in July, August, and September at the PN outfalls at three locations each (i.e., ~100 m, 250 m and 500 m from discharge). Additional samples were collected at locations 500 m and 1000 m east and west of the discharge at a location 200 m from shore, as shown in Figure 3.3 and EcoMetrix (2015). As shown in Table A.3, the maximum observed hydrazine concentration (0.25 µg/L) was higher than the screening level of 0.01 µg/L; therefore, hydrazine is carried forward for further quantitative assessment in the HHRA.

Table 3.2: Lake Surface Water 2015 Sampling Locations and Descriptions

Location	Sample ID	UTM Easting and Northing	Description	Sample Depth (m)	Depth to Bottom (m)
PN outfalls	LW-10	655083 E 4852644 N	PN U1-4 outfall (mid channel)	mid-depth sample – 2 m	2.7 to 3.1
	LW-21	655993 E 4852410 N	PN U5-8 outfall (mid channel)	mid-depth sample – 2 m	4.2 to 4.5
PN intake	LW-9	655200 E 4852011 N	south of opening to intake channel (in front of fish diversion net)	0.3 m and 5 m	5.4 to 5.5
Frenchman's Bay mouth	FB-1	653983 E 4852540 N	at a location of 5 m depth at the mouth	0.3 m and 5 m	5.5 to 5.7
PN east side	LWE-1	656580 E 4852203 N	at a location of 5 m depth, offshore of stormwater location M5-1	0.3 m and 5 m	5.3 to 5.7
Lake Ontario control	LWC-1	727080 E 4869401 N	east of PNGS near Cobourg Water Supply Plant	0.3 m and 5 m	16.1 to 16.5

For the current HHRA, a screening was performed, where maximum observed 2015 lake water concentrations near the PN outfalls were screened against PWQOs, CCME water quality guidelines, and federal or provincial drinking water quality guidelines. Drinking water guidelines were used as the preferred screening levels, where available, as they are more relevant to human health than the PWQO or CCME water quality guidelines. During the 2015 sampling events background surface water data were taken from Cobourg (LWC-1). Therefore, where no guideline existed, mean background values from Cobourg were used as screening levels. These background values are in general agreement with the 95th percentile of Lake Ontario background values from the Drinking Water Surveillance Program (DWSP) (MOECC, 2013a) previously used in the 2014 ERA (EcoMetrix, 2014).

For some COPCs without environmental or drinking water quality guidelines (alkalinity, calcium, magnesium, potassium, and strontium), the maximum measured PN lake water concentration marginally exceeded – between 3 and 15% – the mean Lake Ontario background concentration. Differences of less than 20% are typically not statistically discernible or measurable in the field or laboratory (Suter *et al.*, 1995; Suter, 1996). Since the measured concentrations differed from background by less than 20%, these metals are not carried forward for further quantitative assessment.

Based on the lake water screening presented in Appendix A (Table A.3), hydrazine and morpholine are carried forward for further quantitative assessment in the HHRA.

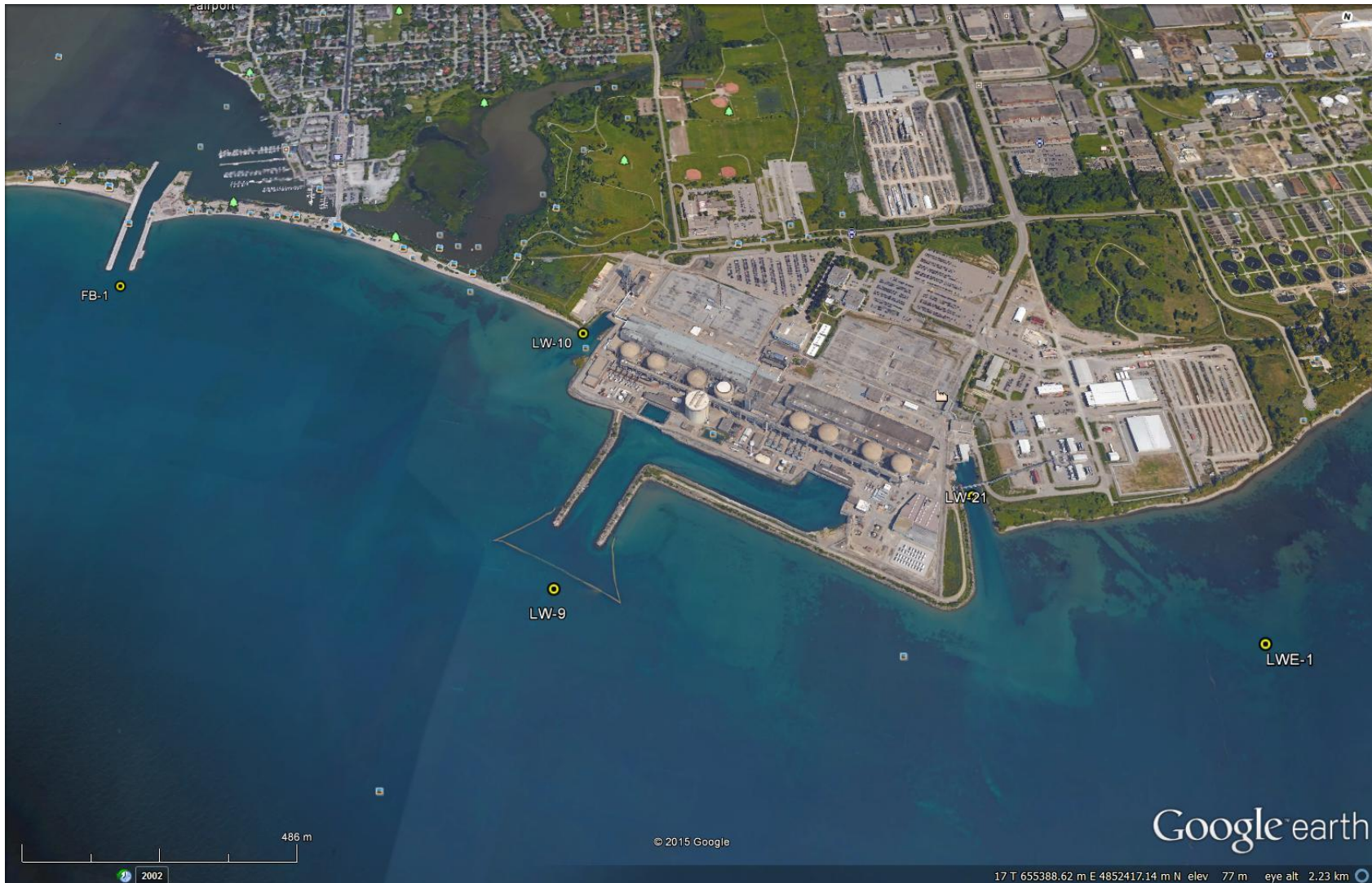

Figure 3.2: 2015 Lake Surface Water Sample Collections



Figure 3.3: Locations of the 2014 Hydrazine Sample Collections near the PN Site (22 July, 15 August and 10 September)

3.1.2.2.3 Stormwater

Stormwater runoff from the PN site is collected by the stormwater drainage system and directed through drainage pathways south to Lake Ontario. Surface drainage around the PN site is comprised of 19 catchments, as shown in Figure 2.17. A brief discussion of the drainage pattern is presented below (Golder, 2007a):

- Catchments 1 and 2 discharge to PN U1-4 discharge channel;
- Runoff from Catchment 3 is collected by catchbasins, directed to a subsurface yard drainage network and discharged directly to Lake Ontario via a submerged outfall;
- Runoff from Catchments 4 and 5 is collected by catchbasins, directed to a subsurface yard drainage network and discharged to the intake channel via submerged outfalls;
- Runoff from Catchment 7 is collected by a system of catchbasins and subsurface drains and discharged to PN U5-8 discharge channel;
- Runoff from Catchment 8 is directed through culverts and ditches and discharged to PN U5-8 discharge channel;
- Catchments 6 and 9 each drain through a pipe into PN U5-8 discharge channel; and
- Catchments 10 through 16A drain directly to the Lake Ontario shoreline. These specific catchment areas are expected to be different with recent developments in the area and the estimated current catchments are shown in yellow. Water in this area however, continues to discharge to the Lake Ontario shoreline. The discharge points are approximately 6 m to 10 m above the Lake Ontario water level.

The 2014 ERA (EcoMetrix, 2014) discussed stormwater data from 1990 to 2006. Overall, the conclusions from the 1997, 2002, and 2006 studies indicate that stormwater quality has not resulted in any unexpected or adverse effects on the environment.

As part of the updated baseline environmental program, a stormwater sampling program was implemented in 2015/2016 to characterize the current quality of stormwater runoff from PN (see Figure 2.17). Additionally, there have been site development/alterations associated with the PWMF DSC Storage Building #3 that may have altered the baseline characteristics of the Pickering Nuclear east site stormwater runoff.

To confirm the conclusion from the stormwater monitoring programs that stormwater quality has not resulted in any adverse effects on the environment, a screening of stormwater quality against water quality guidelines was conducted (Appendix A, Table A.4 to Table A.7). The stormwater quality screening focused on stormwater released to the PN outfalls (Catchments 1, 2, 6, 7, 8, and 9), and stormwater discharged directly to Lake Ontario (Catchments 3 and 10-16A). Concentrations in stormwater discharged into the intake channel (Catchments 4 and 5) were not included in the assessment as that stormwater is redirected into the station. However, for completeness stormwater data from Catchments 4 and 5 are presented in Appendix F. There was one toxicity test failure; however, this water is redirected into the station; therefore, it was not considered of concern.

During the 2015/2016 stormwater sampling program a flow monitor was installed in M2-1 only. The flow at all other locations, with the exception of M5-1, was calculated based on historical rainfall vs flow measurements. The rainfall depth (mm) was multiplied by a volume to depth ratio based on previous sampling events to provide the rainfall volume (m^3) at each location. This volume was divided by the duration of the storm event to provide the flow (m^3/s). This use of historical data was considered valid as these catchment areas had not changed.

The catchment area of M5-1 has however changed with the construction of the PVMF II and other modifications. Based on this change the flow resulting from various rainfall depths was calculated via the Environmental Protection Agency Storm Water Management Model 5.0 (SWMM5) hydrologic model, and verified by the measurements at M2-1. A discussion of this model and verification is provided in Appendix G. For M5-1, the modelled runoff volumes provided in Table G.3 were divided by the duration for each storm event to obtain the flows.

PN Discharge Channels

Stormwater monitoring data from the 2015/2016 study from each relevant catchment were compiled to determine the maximum concentration potentially released to the PN discharge channels. Dilution calculations were performed to determine the concentration in the discharge channel for each of the monitored parameters. The maximum stormwater runoff to PN U1-4 and U5-8 discharge channels is 1.13 and 3.74 m^3/s , respectively. This runoff, from June 2016, is significantly higher than Golder (2007a) and the other three quarters measured in 2015. The stormwater runoff flow used for each discharge channel was the maximum flow of four monitoring events from the applicable catchments. The flowrate used in the calculations for the PN U1-4 discharge channel is 48 m^3/s . The flowrate used for the PN U5-8 discharge channel is 116 m^3/s (Golder, 2007a), which assumes two CCW pumps per unit operating.

Runoff to Lake Ontario

Stormwater monitoring data from the 2015/2016 study from Catchments 10-16A located east of the station and data from Catchment 3 located west of the station were assessed separately. The flow in the wave zone in Lake Ontario was determined based on the assumption that the wave zone extends out to 150 m east of the station and 120 m west of the station and is well mixed over a depth of 2 m (based on the Canadian Hydrographic Service nautical map of the area). The current speed was taken as the average of the easterly and westerly current speeds from Table 2.9 (0.197 m/s). Therefore, lake flow to the east and west of the station is 29.5 m^3/s and 23.6 m^3/s , respectively.

Dilution calculations were performed to determine the concentrations of COPCs in the wave zone at the shoreline of Lake Ontario. Stormwater runoff flowrate was calculated or measured (for M2-1) for each of the four stormwater events monitored in 2015/2016 –

based on the estimated runoff volume and event duration. The maximum loading rate was determined from monitoring data and stormwater runoff. The maximum concentration in the lake was then estimated from the maximum loading rate and lake flow along the shoreline.

Overall Conclusion

The final concentration in each of the discharge channels, and in the lake, resulting from stormwater runoff was compared to water quality guidelines – PWQO, CCME, and Lake Ontario background. The screening tables are presented in Appendix A (Tables A.4 to Table A.7) and there were no exceedances of the selected benchmarks. The results of the screening assessment are in agreement with the conclusions of the previous stormwater monitoring programs.

3.1.2.3 Chemical COPCs in Soil

For the HHRA, potential risks from soil were determined to be of little concern. On-site workers, contractors, and visitors are potentially exposed to on-site soil; however these exposures are considered and controlled through the Health and Safety Management System Program, and are outside of the scope of the HHRA, as discussed in Section 3.1.1.1.1. Human exposure to COPCs from off-site soil is unlikely, since the results of the air screening presented in Section 3.1.2.1 show acceptable concentrations for air contaminants that could deposit on soil. The PN site is not a source of dust. Any releases from PN and subsequent off-site deposition of non-radiological particulates (metals) will be lost against the background soil levels.

An EcoRA screening for non-radiological COPCs in soil is presented in Section 4.1.3.3.

3.1.2.4 Chemical COPCs in Groundwater

A number of hydrogeological investigations have been completed at the PN site primarily related to elevated tritium levels in groundwater (see Section 3.1.2.7), but with some investigations related to other COPCs such as petroleum hydrocarbons and metals in specific potential source areas.

The 2012 PN Groundwater Monitoring Program Design (EcoMetrix, 2012), identified COPCs that should be the focus of the groundwater monitoring program. The selection of COPCs was based on analyzing groundwater data from 2008 to 2012 and comparing against appropriate screening concentrations as well as considering COPCs that were included in past assessments and studies. Groundwater data were screened against MOE (2011) Table 3 standards for groundwater wells located greater than 30 m from Lake Ontario, and Table 9 standards for groundwater wells located less than 30 m from Lake Ontario. For substances without MOE Table standards, data were compared against screening levels based on 10x the lowest of the Ontario PWQO and the CCME water quality guidelines. The 10x factor is consistent with the MOE (2011) derivation of the groundwater to surface water pathway component values, which assumes at least 10-fold dilution of groundwater in surface water. Groundwater constituents were retained for monitoring if they exceeded applicable groundwater standards or screening levels, were identified as part of historical leakages, or were otherwise anticipated to be of potential concern.

Based on the screening assessment of past measurements, polycyclic aromatic hydrocarbons, petroleum hydrocarbons, benzene, toluene, ethylbenzene, and xylenes (BTEX) compounds, and inorganics (chloride, iron and sodium) were recommended as the focus of the groundwater monitoring program at specific locations. Results from groundwater monitoring conducted from 2012 to 2015 (OPG, 2016d; 2015b) are consistent with the previous assessment (EcoMetrix, 2012).

Pinchin (2010) concluded that off-site recreational receptors would not be exposed to COPCs such as polycyclic aromatic hydrocarbons, petroleum hydrocarbons, and BTEX compounds migrating from groundwater to surface water. This conclusion was based on site groundwater flow direction and data in groundwater monitoring wells closest to the intake channel which showed acceptable concentrations of COPCs. Pinchin (2010) concluded that COPCs from the standby generators are not migrating from groundwater to surface water in the intake channel at unacceptable concentrations. Additionally, a recreational resident would not be allowed to swim in the intake channel, and any exposure to recreational users farther away following discharge would be minimal due to massive dilution of the small groundwater flow.

There is potential for site groundwater to migrate to surface water (Lake Ontario); however, groundwater flux from the site into Lake Ontario is likely to be small based on the estimated groundwater velocity and influence of site infrastructure (CH2M Gore and Storrie, 2000); therefore, any COPCs in groundwater that reach the lake are subject to considerable dilution before they can migrate with surface water to a point of water intake for human consumption. The nearest water intake at Ajax is approximately 7 km east of the Pickering Nuclear site and is not at any risk due to constituents in groundwater on the site.

Although COPCs have been identified through the screening assessment in EcoMetrix (2012), the lack of complete exposure pathways for site groundwater to the public indicates that there is no need for inclusion of these pathways in the HHRA.

3.1.2.5 Radiological COPCs in Air and Water

Selected radiological stressors are considered of public interest and therefore are carried forward quantitatively in the HHRA and do not undergo a formal screening assessment. The relevant radionuclides that are the focus of the quantitative assessment are described below.

Airborne and waterborne radioactive emissions from the years 2011 to 2015 were analyzed and compared against radioactive emissions reported in the 2014 Pickering ERA (EcoMetrix, 2014). Emissions from the five year period 2011 to 2015 (see Table 3.3 and Figure 3.4) are within the range of historical emissions reported in the 2014 Pickering ERA (EcoMetrix, 2014). Additionally, average radiological emissions over the 2011 to 2015 period ranged from <0.01 to 0.28% of Derived Release Limits (DRL), as shown in Table 3.3.

The average PN tritium airborne emissions from 2011 to 2015 have decreased slightly compared to average emissions from the 2014 ERA (EcoMetrix, 2014). In 2013, PN tritium airborne emissions trended downwards as a result of improvements in managing emissions, reliability and operation of vapour recovery dryers, and reduction of tritium source terms (OPG, 2016c). The increase in tritium airborne emissions in 2014 was attributed to valve/gasket repairs. Repairs were completed in late 2014 and 2015.

The average PN carbon-14 airborne emissions from 2011 to 2015 have decreased compared to average emissions from the 2014 ERA (EcoMetrix, 2014). Since 2008, airborne carbon-14 emissions have continued trending down. In April 2008, the calandria tube that leaked CO₂ from the annulus gas into the Unit 7 moderator system, was replaced, reducing emissions to pre-2005 levels.

The average particulate emissions from 2011 to 2015 have decreased compared to average emissions from the 2014 ERA (EcoMetrix, 2014). Typically, station particulate emissions are below the detection limit. However, the elevated value in 2015 was due to lab ventilation being out of service for maintenance. During return to service, elevated particulate emissions were observed for one week.

The average tritium waterborne emissions from 2011 to 2015 have decreased marginally compared to average emissions from the 2014 ERA (EcoMetrix, 2014). Tritium waterborne emissions were slightly higher in 2011 than in 2010 because all units were shutdown in 2010 for the duration of the Vacuum Building Outage. The slight increase of tritium waterborne emissions in 2014 was from tritiated water processing activities in active liquid waste (OPG, 2015a). The increase in 2015 is attributed to a valve that allowed service water containing tritium to be discharged. The valve is planned for repair and additional sampling and analysis procedures have been implemented to ensure acceptable tritium limits are met before the effluent is discharged (OPG, 2016c).

The average gross beta waterborne emissions from 2011 to 2015 have decreased compared to average emissions from the 2014 ERA (EcoMetrix, 2014). In 2009 and 2010, gross beta waterborne emissions were elevated compared to previous years; however, a third-party review of station in-house investigations confirmed that the increase was due to anomalous samples of high activity (OPG, 2012d). In 2011, gross beta waterborne emissions from PN decreased to levels observed prior to 2009, and have continued this trend.

The average carbon-14 waterborne emissions from 2011 to 2015 have decreased slightly compared to average emissions from the 2014 ERA (EcoMetrix, 2014). Elevated carbon-14 waterborne emissions in 2012 were due to processing of spent resin storage water.

Table 3.3: Radioactive Emissions from PN

	Parameter	Average (2014 ERA) ¹	Year					Average (2011-2015)	% of DRL ²
			2011	2012	2013	2014	2015		
Air	Tritium (Bq/a)	6.28E+14	5.50E+14	5.30E+14	4.30E+14	5.30E+14	5.40E+14	5.16E+14	0.28
	Noble Gas (γBq-MeV/a)	2.04E+14	1.80E+14	1.20E+14	1.30E+14	1.20E+14	1.10E+14	1.32E+14	0.23
	Iodine-131 (Bq/a)	3.18E+07	2.40E+07	1.70E+07	1.30E+07	1.60E+07	1.80E+07	1.76E+07	<0.01
	Particulate (Bq/a)	5.72E+07	1.20E+07	8.10E+06	8.70E+06	7.90E+06	2.10E+07	1.15E+07	<0.01
	Carbon-14 (Bq/a)	5.22E+12	1.80E+12	1.80E+12	1.70E+12	1.80E+12	2.10E+12	1.84E+12	0.11
Water	Tritium (Bq/a)	3.34E+14	3.10E+14	2.90E+14	3.10E+14	3.40E+14	3.70E+14	3.24E+14	0.05
	Beta-Gamma (Bq/a)	7.50E+10	1.90E+10	3.00E+10	3.30E+10	3.20E+10	2.20E+10	2.72E+10	0.04
	Carbon-14 (Bq/a)	4.34E+09	2.20E+09	1.10E+10	1.70E+09	1.50E+09	2.80E+09	3.84E+09	0.09

Notes:

1. Average from the 2014 ERA (EcoMetrix, 2014) is the sum of emissions from PN U1-4 and PN U5-8.
2. The DRL used for comparison to 2011-2015 average emissions is the PN U5-8 DRL (OPG, 2011b)

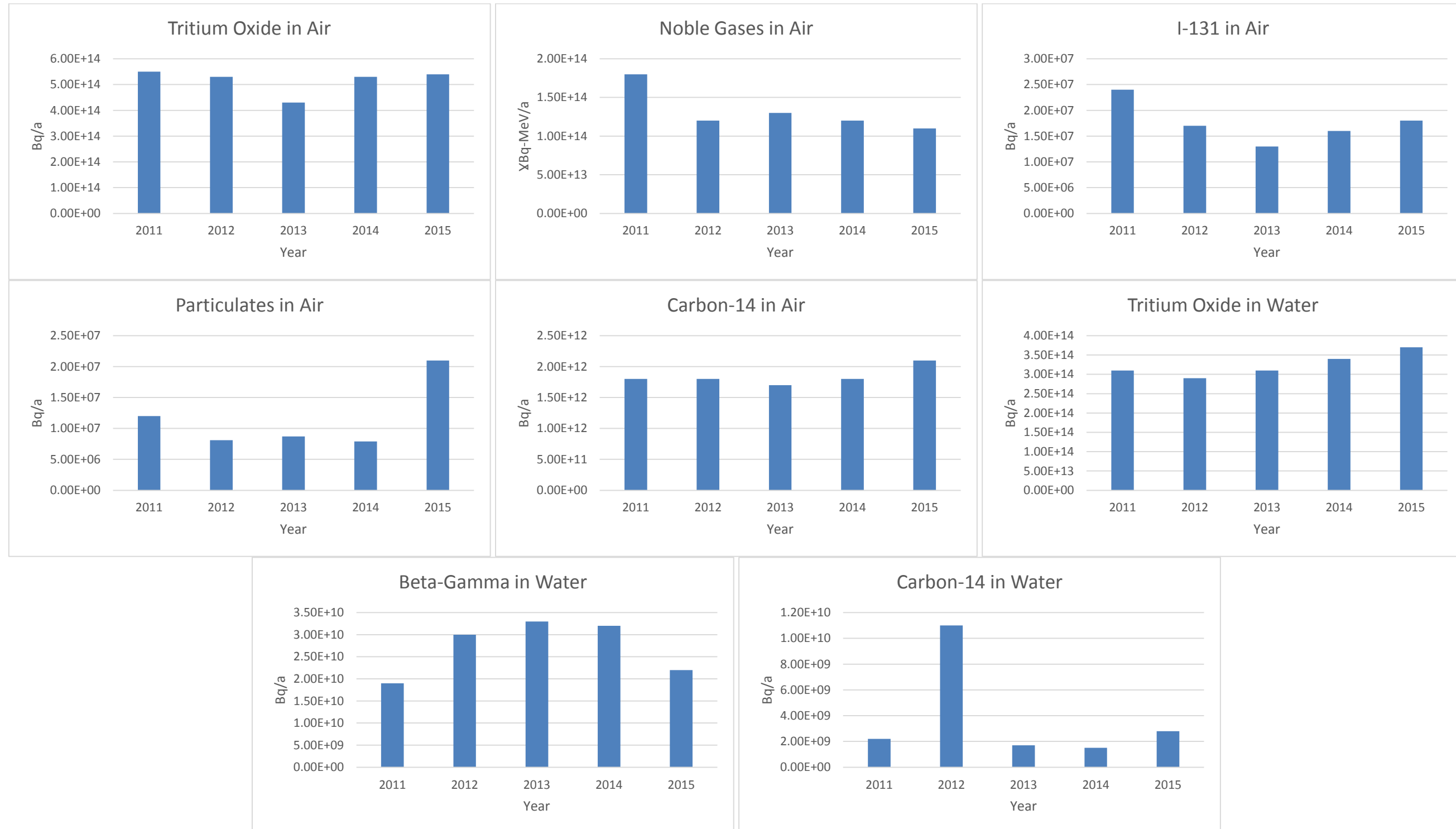

Figure 3.4: Summary of PN Emissions Data from 2011-2015

The Radiation and Radioactivity TSD (SENES, 2007c) identified a number of radionuclides released to air and water that should be carried forward for the dose assessment. The 2011 DRL Report for PN presents the same effluent release groups for air and water, with the exception of including gross alpha for both air and water (OPG, 2011a, b).

The DRLs for the effluent release groups were calculated based on the selection of the radionuclide with the most restrictive DRL, according to the process outlined in the CANDU Owners Group (COG) DRL Guidance document (Hart, 2008). Radionuclides were selected based on the following criteria for inclusion:

- Radionuclides are regularly present in the effluent; and
- Radionuclides represent no less than 1% of the total radioactivity present.

Based on these criteria, the radionuclides selected for use in DRL calculations were considered appropriate for carrying forward in the risk assessment.

The limiting radionuclides (i.e., the radionuclide with the most restrictive DRL) for particulates in air and for gross beta/gamma in water were used to represent all radionuclides in each grouping. The 2011 DRLs (OPG, 2011a, b) indicate that cobalt-60 is the limiting radionuclide for particulates in air. The 2011 DRLs (OPG, 2011a, b) indicate that phosphorous-32 is the limiting gross beta/gamma radionuclide in water; however, using cesium-137 to represent gross beta/gamma in water is considered appropriate since site-specific data exists for fish and sediment and the 2011 DRL for cesium-137 is only slightly higher than the DRL for phosphorous-32, for the Sport Fisher.

Category	Radiological COPC
Air	tritium, noble gases, carbon-14, I (mixed fission products), particulates (phosphorous-32, sulphur-35, scandium-46, chromium-51, manganese-54, iron-59, cobalt-60, zinc-65, strontium-89, strontium-90 (yttrium-90), zirconium-95, niobium-95, ruthenium-106, tin-113, antimony-124, antimony-125, cesium-134, cesium-137, cesium-144, gadolinium-153, barium-140, lanthanum-140, terbium-160, mercury-203, thorium-234)
Surface water	tritium, carbon-14, gross beta/gamma (phosphorous-32, sulphur-35, scandium-46, chromium-51, manganese-54, iron-55, iron-59, cobalt-60, strontium-90 (yttrium-90), zirconium-95, niobium-95, ruthenium-106, tin-113, antimony-124, antimony-125, iodine-131, cesium-137, europium-154, gadolinium-153, terbium-160, zinc-65)

Gross alpha radionuclides do not need to be carried forward for the risk assessment. The level of airborne and waterborne gross alpha emissions from OPG nuclear facilities has been considered to be negligible (OPG, 2005b). This position is supported by determination of alpha activity in the heat transport water and estimates of the maximum probable emission levels under normal and abnormal operating conditions. The airborne

exhaust systems at PN contain HEPA filters which continuously filter particulate from the airborne effluents, thus capturing the alpha emitting particles, resulting in negligible emissions. A study on monthly gross alpha waterborne emissions was performed to establish an appropriate monitoring methodology (OPG, 2006b). Based on 2015 monitoring data, gross alpha waterborne concentrations at PN RLWMS are at Method Detection Limit (MDL) and their emissions are at a very small fraction (0.00002%) of the monthly DRL. Based on 2015 monitoring data, gross alpha airborne emissions are approximately 0.0005% of the weekly DRL.

3.1.2.5.1 Pickering Waste Management Facility

As discussed in Section 2.1, the PWMF is comprised of the PWMF Phase I site and PWMF Phase II site. Dose rate calculations were performed as part of the PWMF Safety Analysis Report (OPG, 2013a).

Table 3.4 summarizes the expected conservative dose rates based on the PN property boundary locations near the facilities, when the facilities are at full capacity and at existing baseline capacity. The fields outside the DSC storage buildings are due primarily to contributions from direct gamma radiation and secondarily from gamma skyshine. The neutron dose rate is negligible compared to gamma dose rates.

In 2000, air kerma rates from the PWMF were measured at various locations over Lake Ontario. At a distance of 500 m from the PWMF, the measured air kerma rate was below the detection limit of 0.13 nGy/h. At a distance of 1 km from the PWMF, the air kerma rate was estimated to be negligible assuming an inverse square relationship with distance and a further reduction of a factor of 1,000 due to scattering in air. Based on the 2000 assessment, it was determined that air kerma rates from the PWMF are not significant for critical groups farther than 1 km from the source – all critical groups except for the Sport Fisher.

The annual contribution to the Sport Fisher dose from the PWMF is estimated in the exposure assessment for the HHRA.

Table 3.4: Expected Dose Rates at Boundary Locations from PWWF Phase I and Phase II

Site	Location	Dose Rate ($\mu\text{Sv/h}$) at full capacity (OPG, 2013a)
PWWF Phase I	inland station exclusion boundary, 850 m east of the building wall	6E-06
	eastern lakeside exclusion zone boundary (420 m)	6E-04
PWWF Phase II	Pickering NGS east property boundary	1.1E-03
	lakeside exclusion zone boundary (about 340 m south-east over Lake Ontario at the closest location)	9.7E-04

Notes:

Baseline assumes PWWF Phase I at 25% capacity, PWWF Phase II at 48% capacity.

3.1.2.6 Radiological COPCs in Soil

The Radiation and Radioactivity TSD (SENES, 2007c) identified cesium-134, cesium-137, cobalt-60, and potassium-40 as relevant COPCs for soil and sediment. However, potassium-40 is environmentally abundant and not associated with station operations. The cesium and cobalt isotopes are included as COPCs in order to address potential concern about deposition of particulate activity. Only cesium-134 and cobalt-60 are specific to reactor operations, and these are typically not detected in EMP monitoring of either soil or sediment around the facility (OPG, 2012d). The presence of cesium-137 is primarily due to atmospheric weapons test fallout and not reactor operations. However, exposure to cesium-134, cesium-137, and cobalt-60 in soil are included in the public dose calculations and are therefore carried forward as COPCs.

On-site workers, contractors, and visitors are potentially exposed to on-site soil; however these exposures are considered and controlled through the Health and Safety Management System Program and Radiation Protection Program, and are outside of the scope of the HHRA, as discussed in Section 3.1.1.1.1. Human exposure to COPCs from off-site soil is unlikely, since the results of the air screening presented in Section 3.1.2.1 show acceptable concentrations for air COPCs that could deposit on soil.

3.1.2.7 Radiological COPCs in Groundwater

A number of hydrogeological investigations have been completed at the PN site primarily related to elevated tritium levels in groundwater, which is the focus of OPG's groundwater monitoring program.

There is potential for site groundwater to migrate to surface water (Lake Ontario); however, groundwater flux from the site into Lake Ontario is likely to be small based on the estimated groundwater velocity and influence of site infrastructure (CH2M Gore and Storrie, 2000); therefore, any COPCs in groundwater that reach the lake are subject to considerable

dilution before they can migrate with surface water to a point of water intake for human consumption. The nearest water intake at Ajax is approximately 7 km east of the Pickering Nuclear site and is not at any risk due to constituents in groundwater on the site.

Although the atmospheric release of tritium from PN influences tritium concentrations in groundwater on-site, the on-site groundwater is not considered potable. There are no groundwater supply wells downgradient of potential source areas on-site. Off-site drinking water wells are influenced by the atmospheric tritium plume and this is taken into account in the public dose calculations as part of the annual EMP.

3.1.2.8 Noise

Noise is the only physical stressor mentioned in CSA N288.6-12 as a potential human stressor, and is the only physical stressor associated with PN that is of potential concern to humans. Physical stressors relevant to ecological receptors are discussed in Section 4.1.3.11.

Noise emissions from PN originate from various on-site noise sources. The PN site has an ECA (OPG, 2015f) which includes an assessment of on-site noise sources (OPG, 2011c). An ECA is an environmental approval issued by the Ontario Ministry of the Environment and Climate Change (MOECC) that helps to protect the natural environment from emissions such as air and noise, but is not a human health assessment. According to the PN ECA, noise originates from the following onsite activities:

- West Annex Active Ventilation System;
- Standby gas turbine generating sets for both PN U1-4 and U5-8;
- Emergency power supply generators;
- Auxiliary steam boiler;
- Switchyard equipment and breakers;
- East Annex Active Ventilation System;
- Powerhouse ventilators;
- Steam venting;
- Emergency signals; and
- Auxiliary Power Supply.

Past noise assessments conducted at receptor locations within the vicinity of the PN concluded that noise levels were compliant with the appropriate noise level limits (OPG, 2011c).

As part of the updated baseline environmental program, a noise monitoring program was carried out to monitor existing ambient noise levels. The noise monitoring program included collecting existing noise levels for two environmental components: Environmental Noise (human receptors) and Environmental Noise (ecological receptors). Results for the noise monitoring program for ecological receptors is discussed in Section 4.1.3.11.1.

As defined by the MOECC noise guideline, “*NPC 300 Environmental Noise Guideline, Stationary and Transportation Sources – Approval and Planning*” (NPC 300) (MOECC, 2013b), exclusionary sound level limits are defined for the Daytime, Evening and Night-time periods as follows:

- Daytime – 07:00 to 19:00;
- Evening – 19:00 to 23:00; and
- Night-time – 23:00 to 07:00.

The Environmental Noise (human receptors) locations, also known as Point(s) of Reception (POR(s)), located in the vicinity of PN are in areas defined as Class 1 and Class 2 as per NPC 300 (MOECC, 2013b). A Class 1 area can be described as a major population centre and a Class 2 area can best be described as a blend of an urban and rural area.

According to NPC 300, the One Hour L_{eq} MOECC exclusionary sound level limits for a POR in a Class 1 and Class 2 area are summarized in Table 3.5, and used to assess compliance of stationary noise sources of a facility for the purposes of an ECA. These sound level limits are presented for comparison purposes only. As per NPC 300 (MOECC, 2013b), a Plane of Window (POW) location represents a point in space corresponding with the location of the centre of a window of a noise sensitive space (typically the top storey of a dwelling is the worst case location) and an Outdoor location represents a point within 30 m of a façade of a dwelling at a height of 1.5 m above ground. POW and Outdoor locations are located at different parts of a POR property.

Table 3.5: Sound Level Limits for Class 1 and Class 2 Areas

Time Period	Class 1 POW (Plane of Window) MOECC Exclusionary Sound Level Limit (dBA)	Class 1 Outdoor MOECC Exclusionary Sound Level Limit (dBA)	Class 2 POW (Plane of Window) MOECC Exclusionary Sound Level Limit (dBA)	Class 2 Outdoor MOECC Exclusionary Sound Level Limit (dBA)
Daytime (07:00 – 19:00)	50	50	50	50
Evening (19:00 – 23:00)	50	50	50	45
Night-time (23:00 – 07:00)	45	N/A	45	N/A

Notes:

It is understood the MOECC has generally set these limits for a given classification based on a review of their research, which showed that these levels represent a level where, if a facility were to meet these limits, potential adverse effects are expected to be minimized.

Long-term unattended noise monitoring at Environmental Noise (human receptors) locations was carried out from September 25 to October 9, 2015 with approximately 275 to 330 hours of data collected at each noise monitoring location. During the long-term unattended noise monitoring program, noise data were logged continuously on an hourly basis. The long-term unattended noise monitoring locations are shown on Figure 3.12 and described in Table 3.6 (NM-1 to NM-3). For the Environmental Noise (human receptors) locations, approximately 180 to 230 hours of data were considered to be valid as some of the monitoring levels could have been impacted by inclement weather. Periods of inclement weather, unsuitable for noise measurements, were identified and excluded from the calculations. Short-term attended measurements (i.e., noise measurements ranging between 5 minutes and 30 minutes in duration) were also carried out to provide additional data for areas between long-term unattended noise monitoring locations (ANM-1 to ANM-3).

Table 3.6: Noise Monitoring Locations and Descriptions

Sampling ID	Description	MOECC Classification	Receptor Type	Noise Monitoring Duration
NM-1	Residential Area (Parkham Crescent)	Class 1	Human	Long-term
NM-2	Institutional Area	Class 2	Human	Long-term
NM-3	Residential Area (Annland Street)	Class 1	Human	Long-term
ANM-1	Residential Area (Park at rear of residences)	Class 1	Human	Short-term
ANM-2	Institutional Area (open area)	Class 2	Human	Short-term
ANM-3	Residential Area (Park at rear of residences)	Class 1	Human	Short-term

Environmental noise levels vary over time, and are described using an overall sound level known as the L_{eq} , or energy averaged sound level. The L_{eq} is the equivalent continuous sound level, which in a stated time, and at a stated location, has the same energy as the time varying noise level. It is common practice to measure L_{eq} sound levels in order to obtain a representative average sound level. The L_{90} is defined as the sound level exceeded for 90% of the time and typically is used as an indicator of the “ambient” noise level. A-weighted (dBA) noise levels are used to describe human responses to noise. The A-weighted equivalent continuous sound level is represented by L_{Aeq} .

The noise levels collected during the long-term unattended noise monitoring field program for the Environmental Noise (human receptors) locations are summarized in Table 3.7 to Table 3.10. Figure 3.5 to Figure 3.10 have been developed which present the minimum, maximum, average and MOECC POW and Outdoor sound level limits. NPC 300 POW and Outdoor noise level limits have been included for comparison purposes only. Figure 3.11 provides the entire dataset, which includes a discrete number of periods with increased sound levels. The grey areas within Figure 3.11 represent periods of inclement weather. Noise data with the grey areas were not included in the calculation of the reported values. The results for short-term attended noise monitoring are summarized in Table 3.10.

Further to the noise data presented, during the short-term attended noise monitoring and during setup of the long-term unattended noise monitoring equipment at the Environmental Noise (human receptors) locations, it was generally observed that the local acoustic background consists of the sounds of road traffic, some contribution from activities at PN (such as standby generator testing), and activities from neighbouring sites. In areas near the shoreline, it was observed that the sounds of wave action dominate the acoustic environment. Two of the Environmental Noise human receptor locations (NM-1 and NM-2) are consistent with locations from a previous noise assessment (OPG, 2011c), and the results are comparable.

Since there are periods of recorded maximum sound levels above the NPC 300 Class 1 and Class 2 sound level limits, noise is carried forward as a COPC in the HHRA.

Table 3.7: Environmental Noise (human receptors) – NM-1 Long-term Unattended Noise Monitoring Data Results

Time Period	L_{Aeq} (1-h)			L_{A90} (1-h)		
	Average (dBA)	Maximum (dBA)	Minimum (dBA)	Average (dBA)	Maximum (dBA)	Minimum (dBA)
Daytime (07:00 – 19:00)	54	70	44	50	66	38
Evening (19:00 – 23:00)	49	55	43	47	53	40
Night-time (23:00 – 07:00)	51	63	42	49	61	39
24h	52	70	42	49	66	38

Note: (1) See Table 3.5 for the reference MOECC sound level limits.

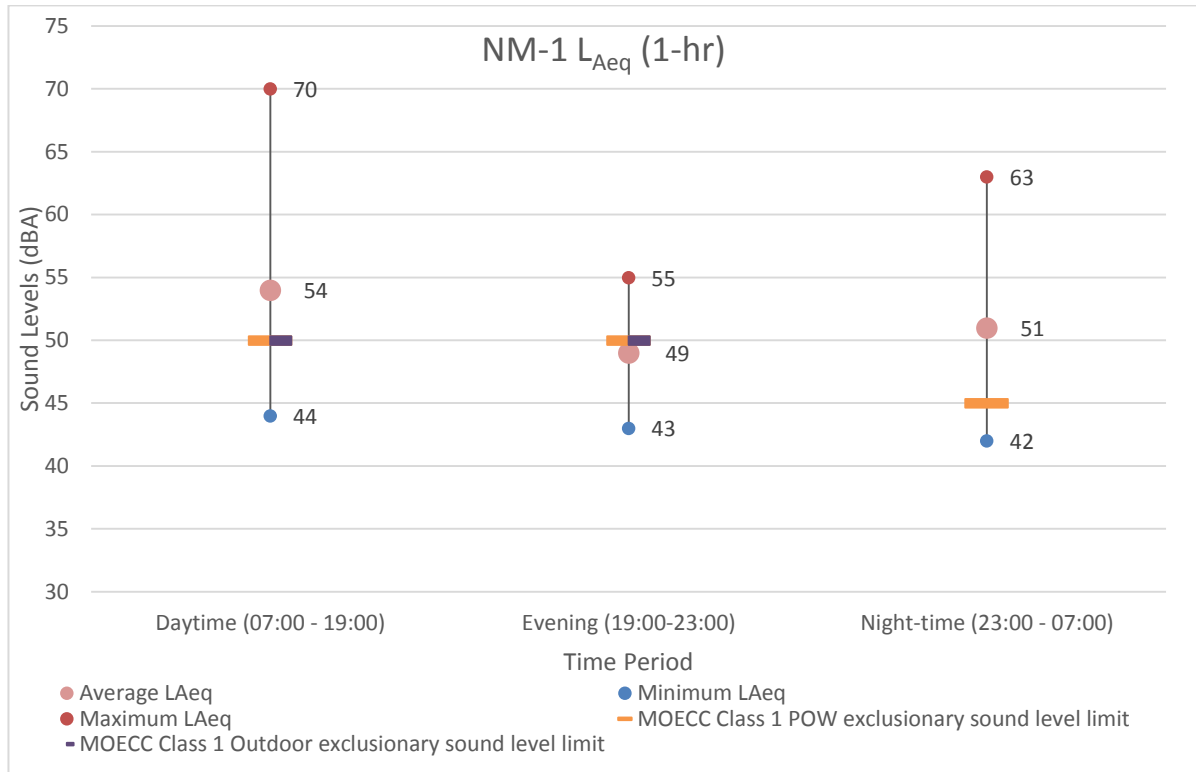

Figure 3.5: NM-1 Long-term Unattended Noise Monitoring LAeq (1-h) Overall Results

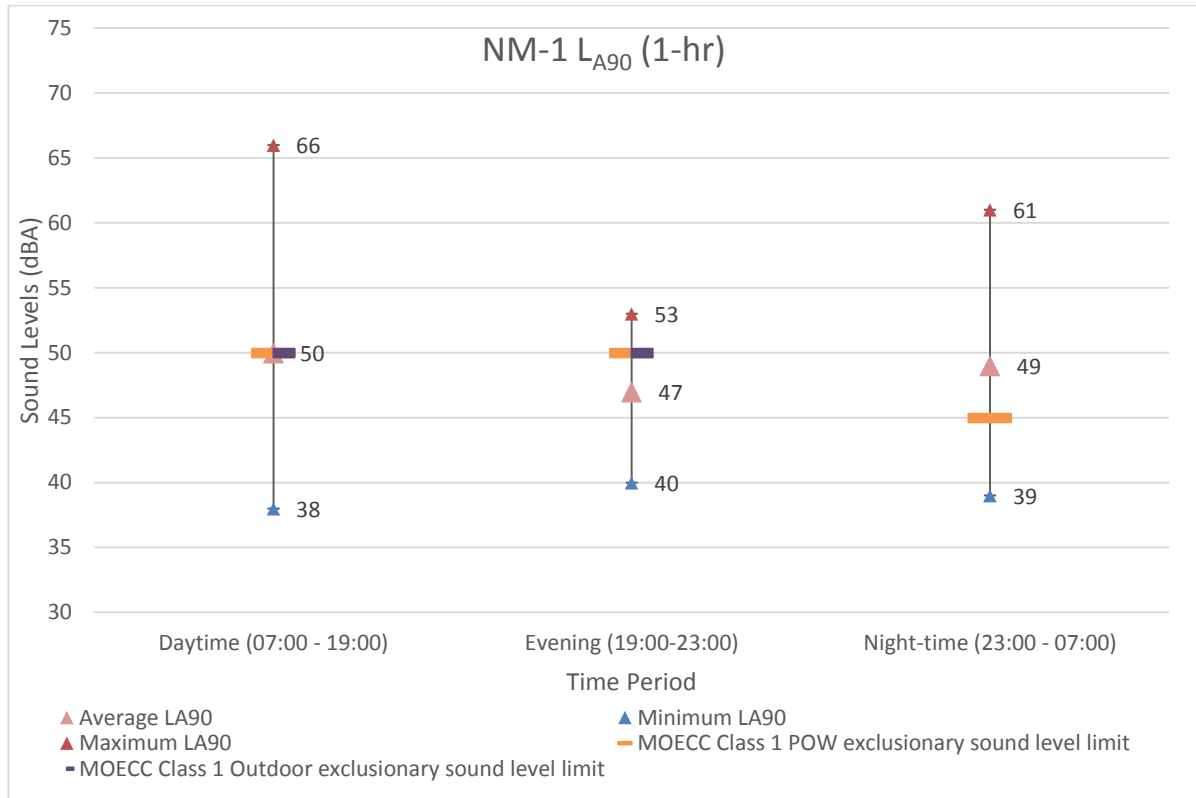

Figure 3.6: NM-1 Long-term Unattended Noise Monitoring LA90 (1-h) Overall Results

Table 3.8: Environmental Noise (human receptors) – NM-2 Long-term Unattended Noise Monitoring Results

Time Period	L _{Aeq} (1-h)			L _{A90} (1-h)		
	Average (dBA)	Maximum (dBA)	Minimum (dBA)	Average (dBA)	Maximum (dBA)	Minimum (dBA)
Daytime (07:00 – 19:00)	54	62	46	50	56	43
Evening (19:00 – 23:00)	53	62	45	49	56	41
Night-time (23:00 – 07:00)	53	61	43	50	56	41
24h	54	62	43	50	56	41

Note: (1) See Table 3.5 for the reference MOECC sound level limits.

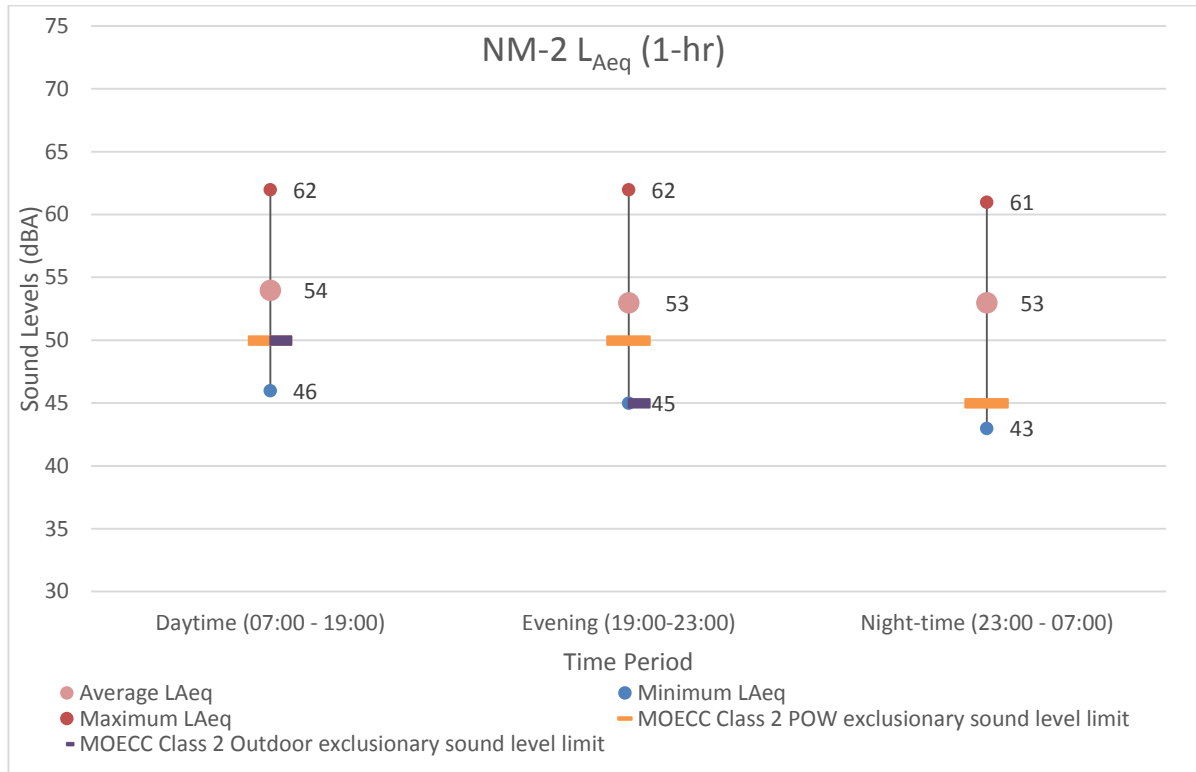

Figure 3.7: NM-2 Long-term Unattended Noise Monitoring LAeq (1-h) Overall Results

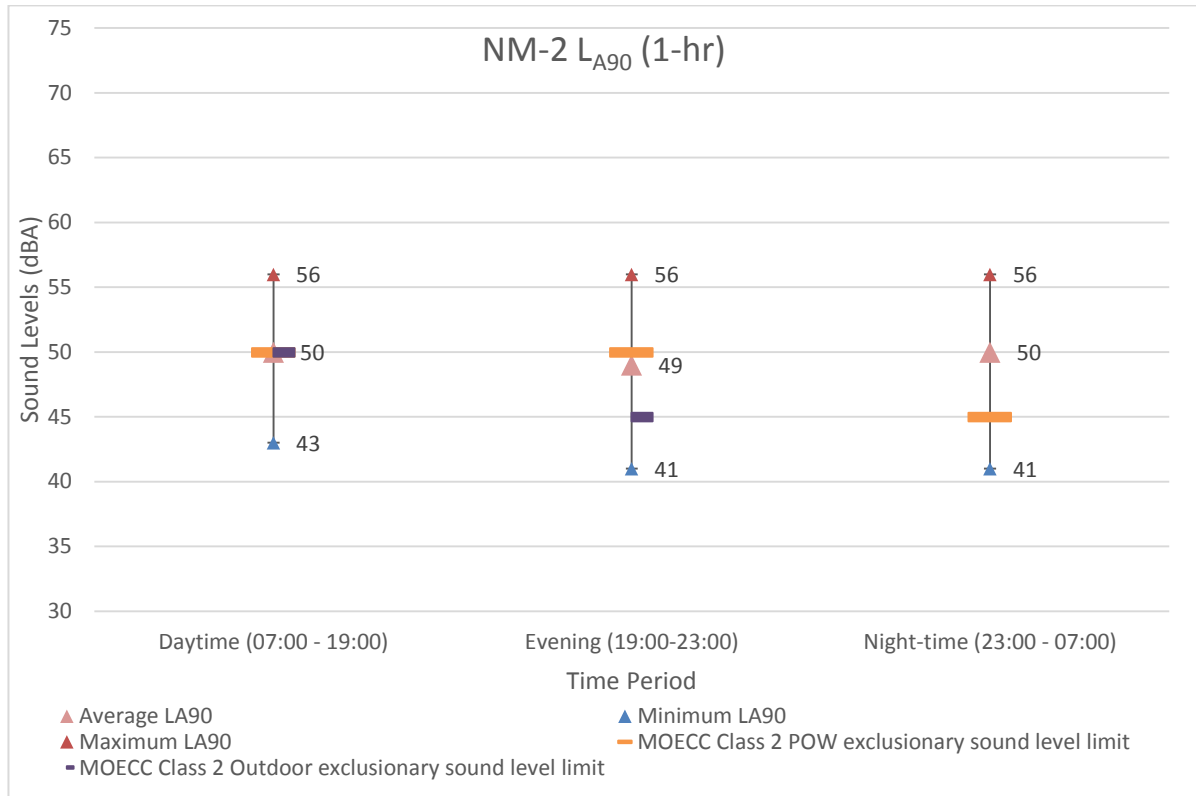

Figure 3.8: NM-2 Long-term Unattended Noise Monitoring LA90 (1-h) Overall Results

Table 3.9: Environmental Noise (human receptors) – NM-3 Long-term Unattended Noise Monitoring Results

Time Period	LAeq (1-h)			LA90 (1-h)		
	Average (dBA)	Maximum (dBA)	Minimum (dBA)	Average (dBA)	Maximum (dBA)	Minimum (dBA)
Daytime (07:00 – 19:00)	53	67	43	47	59	38
Evening (19:00 – 23:00)	47	51	39	45	50	35
Night-time (23:00 – 07:00)	49	58	36	46	54	34
24 h	52	67	36	46	59	34

Note: (1) See Table 3.5 for the reference MOECC sound level limits.

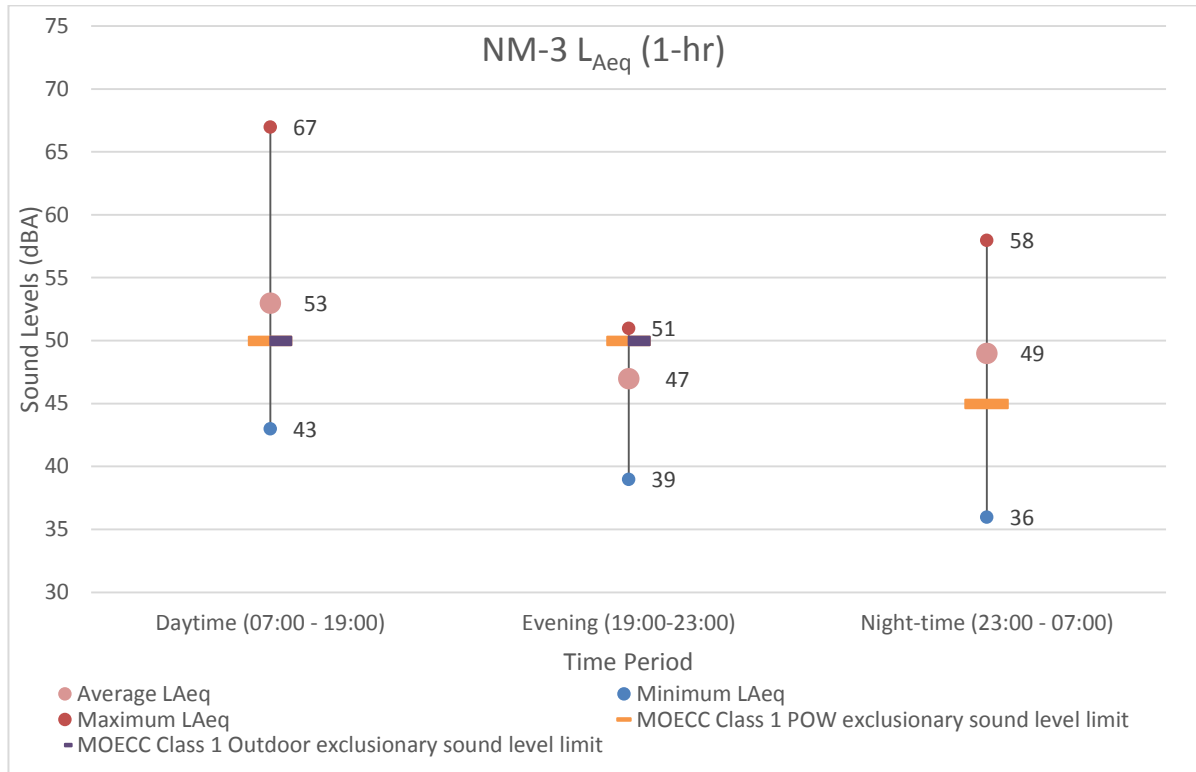

Figure 3.9: NM-3 Long-term Unattended Noise Monitoring LAeq (1-hr) Overall Results

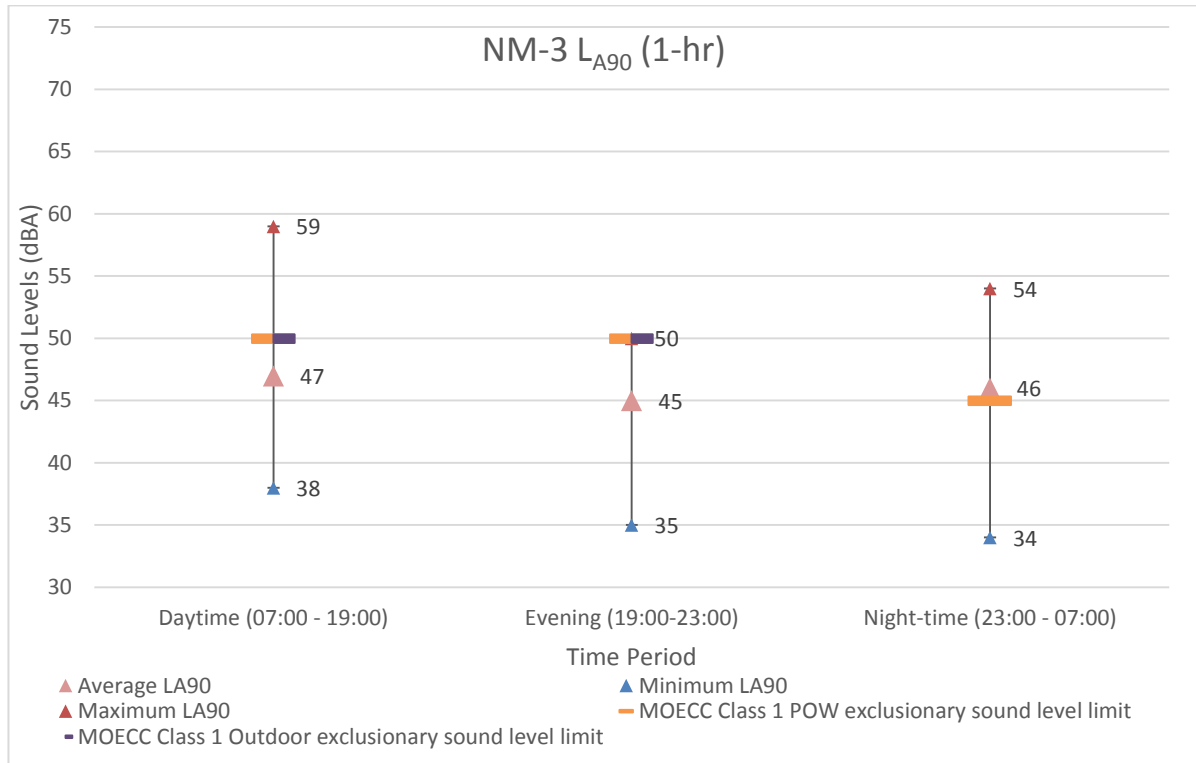

Figure 3.10: NM-3 Long-term Unattended Noise Monitoring LA90 (1-h) Overall Results

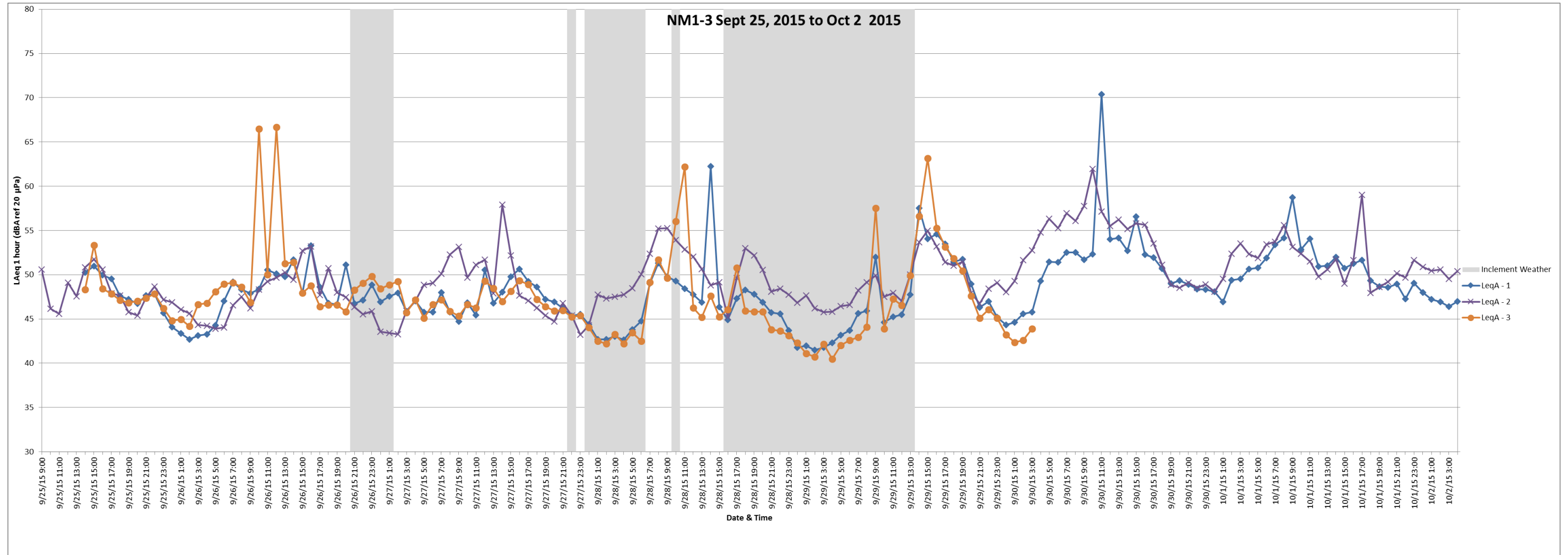

Figure 3.11: Environmental Noise Dataset (L_{Aeq} (1 h))

Table 3.10: Environmental Noise (human receptors) –Short-term Attended Noise Monitoring Results

ID	Date/Time	Height above grade (m)	L_{Aeq} (1-h) (dBA)	L_{A90} (1-h) (dBA)
ANM-1	2015-10-02 15:57 (Daytime)	4.5	52	48
ANM-2	2015-09-25 11:16 (Daytime)	4.5	56	54
ANM-3	2015-09-25 12:43 (Daytime)	4.5	48	45

Note: (1) See Table 3.5 for the reference MOECC sound level limits.

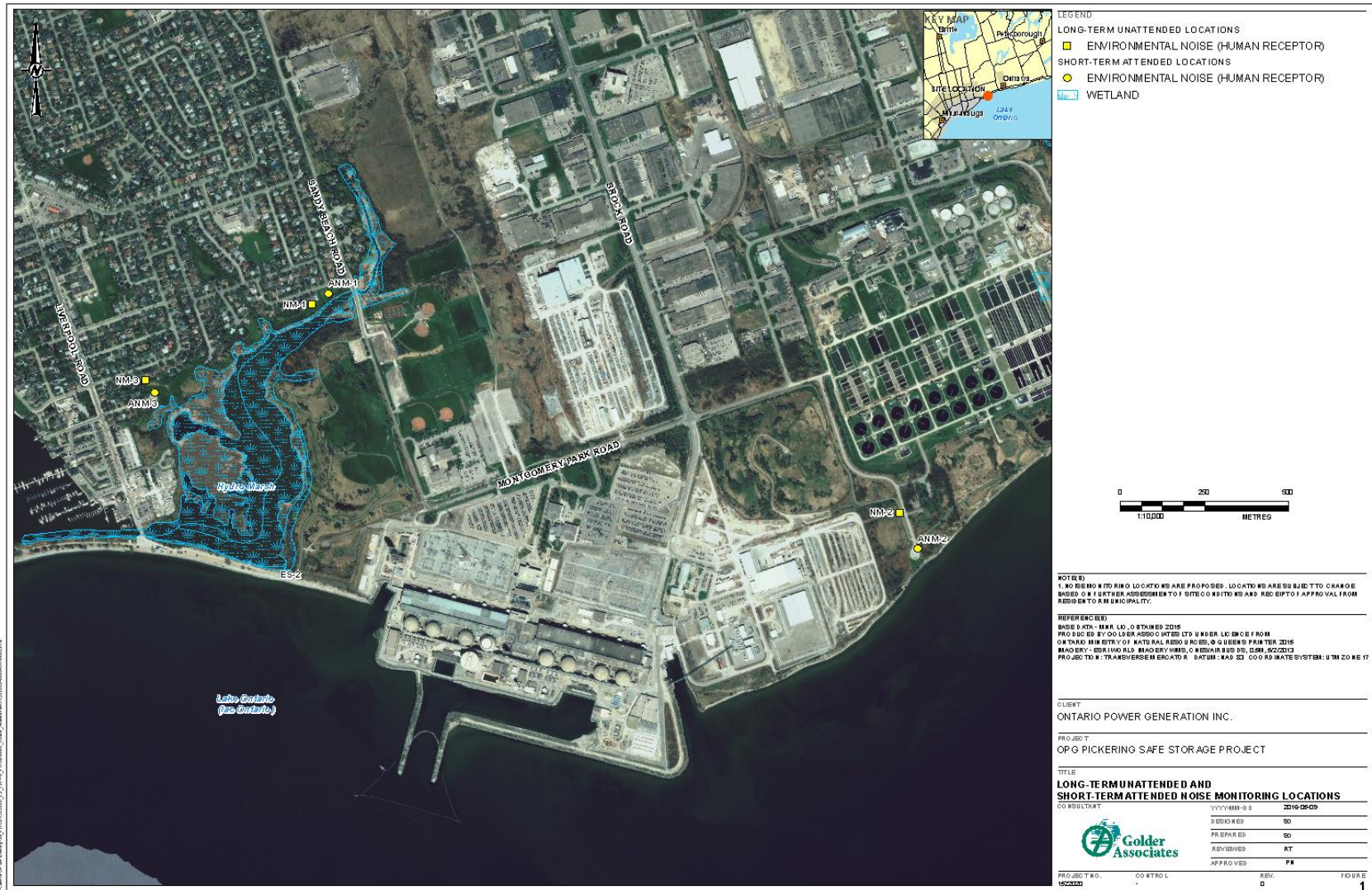

Figure 3.12: Environmental Noise (Human Receptors) - Long-term Unattended and Short-term Attended Noise Monitoring Locations

3.1.2.9 Summary of COPC Selection for the HHRA

Table 3.11 summarizes the radiological and non-radiological COPCs that are carried forward to the exposure assessment in the HHRA.

Table 3.11: Summary of COPCs Selected for the HHRA

Category	Radiological COPC	Non-Radiological COPC
Air	tritium, noble gases, carbon-14, I (mixed fission products), mixed beta/gamma particulates (represented by cobalt-60)	hydrazine
Surface water	tritium, carbon-14, gross beta/gamma (represented by Cesium-137)	hydrazine morpholine
Groundwater	None	None
Stormwater	None	None
Soil	cesium-134, cesium-137, cobalt-60	None
Noise	Yes	

3.1.3 Selection of Exposure Pathways

For exposure of human receptors to non-radiological COPCs the potential exposure pathways include:

- ingestion of water;
- dermal contact with water;
- inhalation;
- incidental ingestion of dust (inhalation), soils and sediment;
- dermal contact with soils and sediment; and
- ingestion of food.

Not all exposure pathways are considered complete. A complete exposure pathway consists of a contaminant source, release mechanism, transport mechanism within the relevant environmental medium (or media), point of exposure and exposure route to a receptor. Based on the COPC screening presented in Section 3.1.2, the complete exposure pathways for exposure of relevant human receptors to non-radiological COPCs generally include inhalation and ingestion, and are summarized in Table 3.12.

Hydrazine does not partition well into other environmental compartments. The environmental partitioning of hydrazine was modeled and described in EC/HC (2011). The modeling results show that when hydrazine is released to surface water (alkaline hardwater), it will remain almost entirely in the water (99.9% in water, 0.02% in sediment). Similarly when hydrazine is released to air, it will remain almost entirely in air (90% in air,

9.6% in water, 0.51% in soil, and 0.01% in sediment). For hydrazine, the relevant exposure pathways for humans are inhalation and ingestion (water and fish).

When morpholine is released to surface water, modelling shows that it will remain almost entirely in water (96.1% water, 3.9% air) and that in general it prefers to distribute to the water compartment (ECHA, 2008). For morpholine, the relevant exposure pathways for humans are ingestion (water and fish).

For exposure of human receptors to radiological COPCs, the relevant exposure pathways include:

- inhalation of air and external exposure to air;
- ingestion of water and external exposure to water;
- incidental ingestion of soil and sediment;
- external exposure to soil and sediment; and
- ingestion of food.

The complete exposure pathways, as defined in OPG's EMP, for exposure of relevant human receptors to radiological COPCs are summarized in Table 3.13.

Although COPCs have been identified in the screening for groundwater, there are no operable groundwater exposure pathways for humans. EcoMetrix (2012) indicated that there are no groundwater supply wells downgradient of potential source areas of COPCs; therefore, human consumption of contaminated groundwater is not a relevant pathway and is not a concern. Additionally, Pinchin (2010) concluded that although there is potential for site groundwater to migrate to Lake Ontario where a human receptor could be exposed through dermal contact and/or ingestion, off-site recreational receptors would not likely be exposed to COPCs migrating from groundwater to surface water at unacceptable concentrations, as discussed in Section 3.1.2.7.

Off-site drinking water wells are influenced by the atmospheric tritium plume and this is taken into account in the public dose calculations as part of the annual EMP.

Table 3.12: Complete Exposure Pathways for Relevant Receptors for Exposure to Non-Radiological COPCs

Location	Receptor	Exposure Pathway	Environmental Media
Outfall (500 m S)	Sport Fisher	Inhalation	Air
		Ingestion	Aquatic animals (fish)
0.9 km NE	Industrial/Commercial Worker	Inhalation	Air
		Ingestion	Water (Ajax WSP)
1.2 km WNW	Urban Resident	Inhalation	Air
		Ingestion	Water (Ajax WSP)
3.1 km NNE	Correctional Institution	Inhalation	Air
		Ingestion	Water (Ajax WSP)
6.9 km NE	Farm	Inhalation	Air
10.25 km NE	Dairy Farm	Inhalation	Air

Table 3.13: Complete Exposure Pathways for Relevant Receptors for Exposure to Radiological COPCs

Receptor	Exposure Pathway	Environmental Media
Sport Fisher	Inhalation	Air
	Ingestion	Aquatic animals (fish)
	External	Air
Industrial/Commercial Worker ⁽¹⁾	Inhalation	Air
	Ingestion	Water Soil (incidental) Sediment (incidental) Aquatic animals Terrestrial plants Terrestrial animals
	External	Air Water Soil Sediment
Urban Resident	Inhalation	Air
	Ingestion	Water Soil (incidental) Sediment (incidental) Aquatic animals Terrestrial plants Terrestrial animals

Receptor	Exposure Pathway	Environmental Media
	External	Air Water Soil Sediment
Correctional Institution	Inhalation	Air
	Ingestion	Water Soil (incidental)
	External	Air Water Soil
Farm	Inhalation	Air
	Ingestion	Water Soil (incidental) Sediment (incidental) Aquatic animals Terrestrial plants Terrestrial animals
	External	Air Water Soil Sediment
Dairy Farm	Inhalation	Air
	Ingestion	Water Soil (incidental) Sediment (incidental) Terrestrial plants Terrestrial animals
	External	Air Water Soil Sediment

Note:

(1) A small fraction of Industrial/Commercial workers are also urban residents; therefore, the ingestion pathway is included to account for when the worker is at home.

3.1.4 Human Health Conceptual Model

The conceptual model illustrates how receptors are exposed to COPCs. It represents the relationship between the source and receptors by identifying the source of contaminants, receptor locations and the exposure pathways to be considered in the assessment for each receptor. Exposure pathways represent the various routes by which radionuclides and/or chemicals may enter the body of the receptor, or (for radionuclides) how they may exert effects from outside the body.

A generic conceptual model, taken from CSA N288.1 (2008) is shown in Figure 3.13, and is applied to human receptors around PN. This represents the exposure pathways from source to receptor. It is appropriate for radiological and non-radiological COPCs, except that, for non-radionuclides, external and immersion pathways represent dermal exposure.

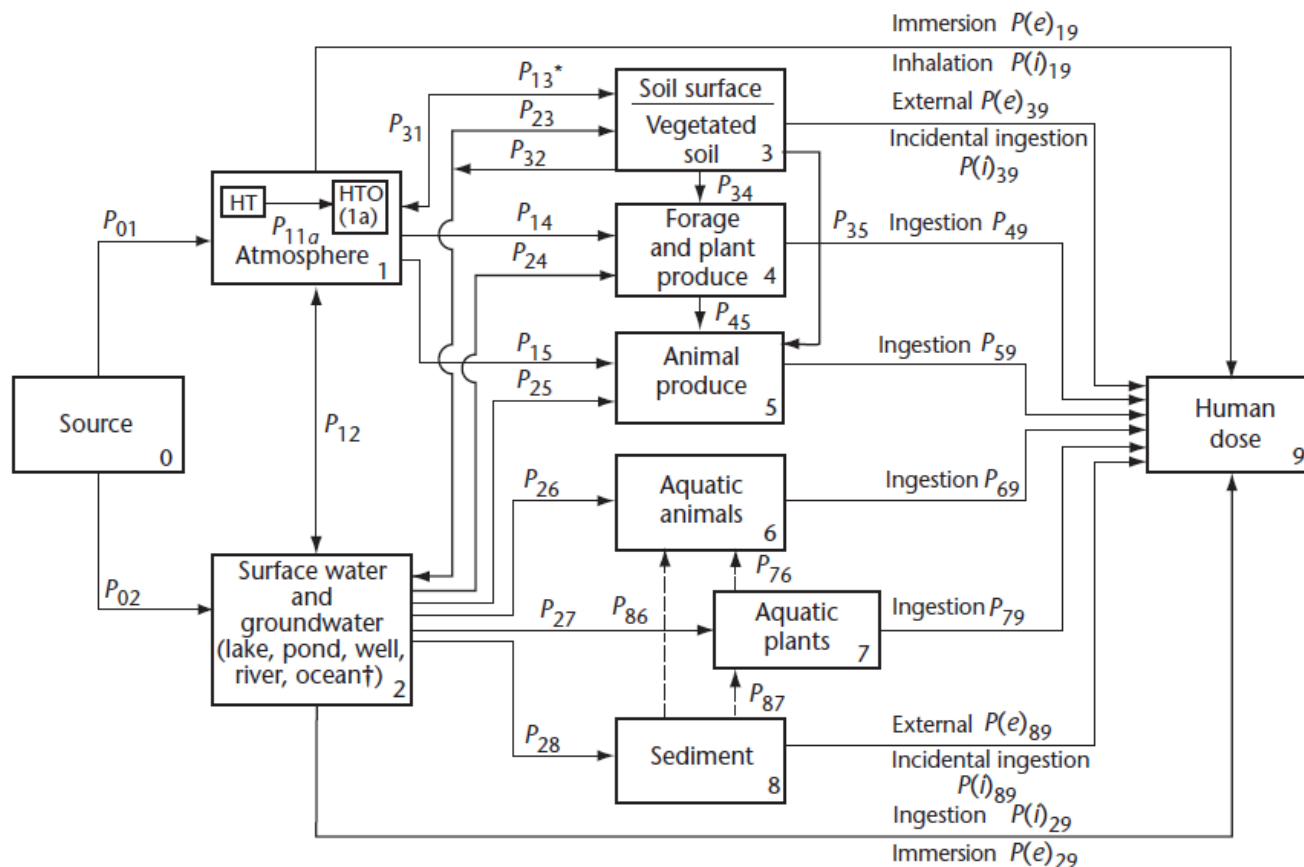

*Includes transfer factors $P_{13\text{area}}$, $P_{13\text{mass}}$, and $P_{13\text{spw}}$.

†For ocean water, pathways P_{23} , P_{24} , P_{25} , and $P(i)_{29}$ are not used.

Notes:

- (1) The broken lines represent pathways that are not explicitly considered in the model, or are considered only in special circumstances.
- (2) Factors include multiple transfers where appropriate.

Figure 3.13: Generic Conceptual Model for Human Receptors (CSA, 2008)

3.1.5 Uncertainties in the Problem Formulation

The data used in the HHRA problem formulation were concluded to be of adequate quality and quantity to support the objectives of the HHRA. Maximum measured concentrations were selected for COPC screening; this is considered conservative and is not reflective of typical human exposures. The human health screening benchmarks for water were generally the lower of applicable provincial and federal drinking water standards and guidelines, which is a conservative approach, ensuring that the list of COPCs would be as comprehensive as possible. The COPC screening also considered several media as sources of potential exposure, such as air, surface water (including Lake Ontario water, effluent, and storm water), soil, ground water, and sediment. As such, the COPC screening has resulted in a conservative list of COPCs.

More generally, the HHRA problem formulation has been conservative in its assumptions to accommodate uncertainties and meet the objective of protecting human health. The conceptual model for human health is considered to be complete for the majority of general public exposures in the vicinity of the PN site. The selected receptors are expected to lead to conservative estimates of health risks, and are expected to be protective of any shorter-term exposures to environmental media in the vicinity of the PN site. The selected exposure pathways are consistent with available guidance (for example, N288.1-08), and are expected to account for all significant exposure pathways for human receptors in the area.

There are uncertainties and conservative assumptions made in the emission estimates and operating conditions for the ESDM (Golder, 2011)

- The highest emission rate that each source is capable of (i.e., maximum usage rates or throughputs) was used to characterize the emissions.
- All sources are assumed to be operating simultaneously at the corresponding maximum emission rate for the averaging period.
- All fuel-fired combustion equipment (i.e., comfort heating and emergency power) emission rates were determined using the highest emission factor, combined with the maximum thermal heat input or engine rating for each piece of equipment.
- Incorporate any other conservative assumptions (e.g. virtual products, 100% volatilization).

Based on the conservative assumptions summarized above the emission rates used for the ESDM are not likely to be an underestimate of the actual emission rates.

There are also uncertainties and conservative assumptions made in the development of the conservative dispersion model inputs for the PN site in the ESDM:

- most sources were modelled as volume sources, which is conservative since this model source type does not take advantage of favourable dispersion characteristics such as plume buoyancy and initial exit velocity of emissions;
- The dispersion modelling source dimensions selected for a given volume source result in a dispersion modelling source which is smaller than the corresponding real-life source. This results in a conservative dispersion modelling scenario for this source since estimated emissions occur over a smaller area and thus are more concentrated (and therefore less dispersed) at the point of release.

3.2 Exposure Assessment

3.2.1 Exposure Locations

The exposure location is the location where the receptor comes into contact with the COPC or stressor. For both the radiological and non-radiological exposure assessment the relevant human receptors are the potential critical groups defined by the EMP, as discussed in Section 3.1.1.1. Table 3.14 and Figure 3.14 present the locations of these receptors. The approximate distance from PN is an average of the distance from PN U1-4 and U5-8 (OPG, 2011a, b). The exposure assessment looked at all six receptors, as reported in the EMP, where appropriate. For the non-radiological exposure assessment, the farm and dairy farm critical groups were not assessed for water ingestion since they obtain the majority of their water intake from waterwells, and not the Ajax WSP.

Table 3.14: Distance and Wind Sector of Potential Critical Groups

Potential Critical Group	Approximate Distance from PN (km)	Wind Sector (Direction TO)	Transfer Parameter from source to air, P_{01} (s/m^3) ⁽³⁾
Farm	6.9	NE	7.0E-08
Dairy Farm	10.25	NNE	4.4E-08
Urban Resident	1.35	WNW	6.9E-07
Industrial/Commercial	0.95	NNE	1.8E-06
Sport Fisher ⁽¹⁾	0.5	S	7.1E-06
Correctional Institution ⁽²⁾	3.1	NNE	2.9E-07

Notes:

- (1) The Fisher group is located 500 m south, offshore of PN site.
- (2) The Correctional Institution is the Kennedy Youth House located 3.1 km NE of PN U1-4
- (3) Transfer parameter (P_{01}) is an average of P_{01} for PN U1-4 and P_{01} for PN U5-8

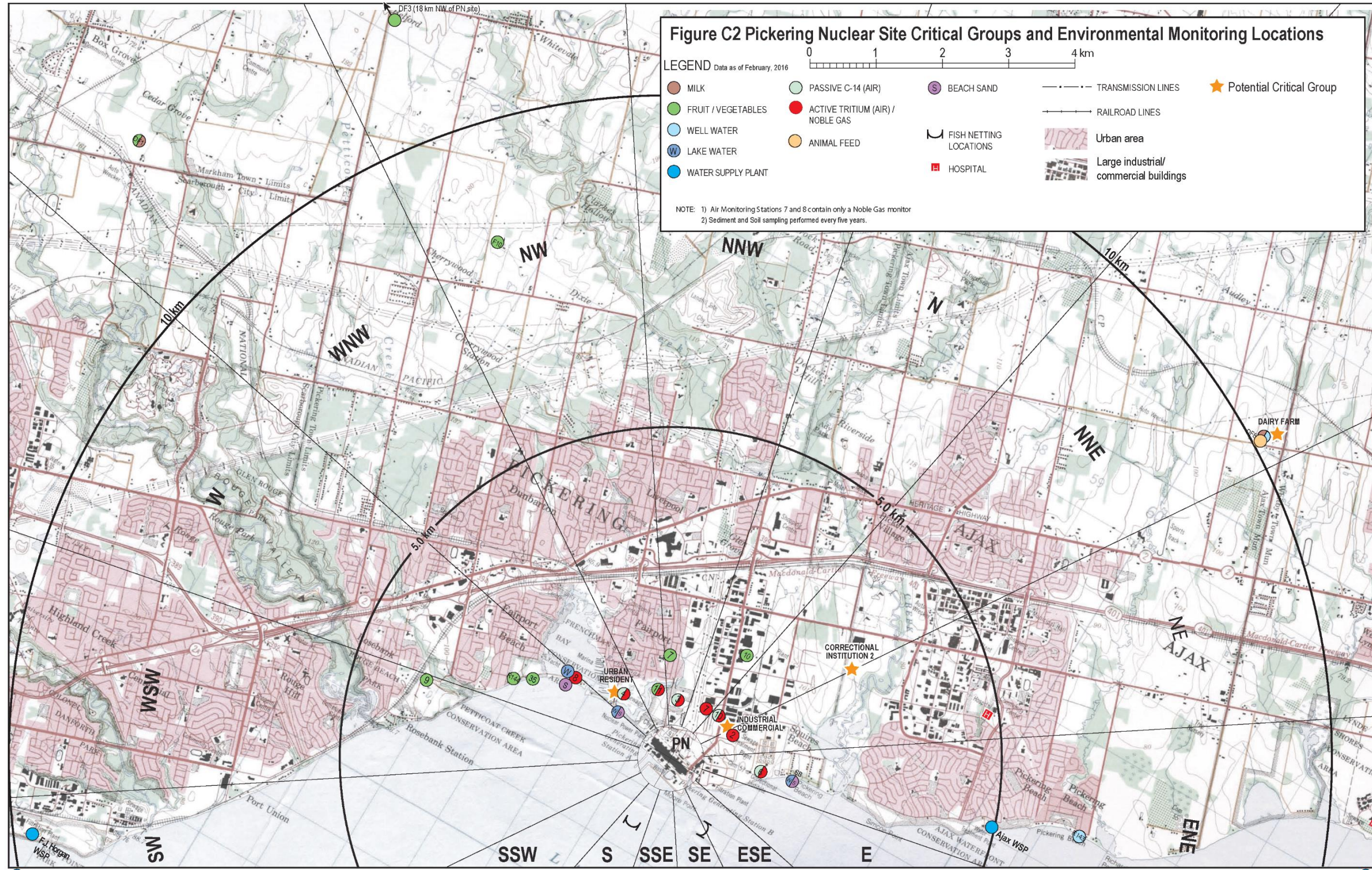

Figure 3.14: Locations of Human Receptors – Potential Critical Groups (OPG, 2016c)

3.2.2 Exposure Duration and Frequency

Full-time residency was assumed for the correctional institute resident, urban resident, farm resident, and dairy farm resident. For the industrial/commercial worker and the sport fisher a residency of 23% and 1% was assumed, respectively (OPG, 2012d).

3.2.3 Exposure and Dose Calculations

3.2.3.1 Radiological Dose Calculations

Radiological dose calculations follow the equations presented in CSA N288.1-08 (2008), which are not reproduced in this report.

3.2.3.2 Non-Radiological Exposure and Dose Calculations

In performing the exposure assessment for inhalation of hydrazine, only the air concentration was used since the incremental lifetime cancer risk (ILCR) is estimated from an air exposure concentration times a unit risk. Therefore, inhalation rates and body weights for receptors are not used. The air exposure concentrations were expressed in units of $\mu\text{g}/\text{m}^3$ factoring in the exposure frequency.

$$\text{Exposure Concentration } (\mu\text{g}/\text{m}^3) = C_{\text{air}} \cdot \text{Fraction of time exposed}$$

where,

C_{air} = air concentration ($\mu\text{g}/\text{m}^3$).

The ingestion dose from exposure to hydrazine and morpholine in drinking water was calculated according to the following equation, consistent with CSA N288.6-12 (CSA, 2012):

$$\text{Dose (mg/kg-d)} = C \cdot \text{IR} \cdot \text{RAF}_{\text{GIT}} \cdot D_2 \cdot D_3 \cdot D_4 / (\text{BW} \cdot \text{LE})$$

where,

C	=	concentration of contaminant in drinking water (mg/L)
IR	=	receptor intake rate (L/d)
RAF_{GIT}	=	absorption factor from the gastrointestinal tract (unitless)
D_2	=	days per week exposed $\cdot (7 \text{ days})^{-1}$ (d/d)
D_3	=	weeks per year exposed $\cdot (52 \text{ weeks})^{-1}$ (wk/wk)
D_4	=	total years exposed to site (years) (for carcinogens only)
BW	=	body weight (kg)
LE	=	life expectancy (years) (for carcinogens only).

The ingestion dose from exposure to hydrazine and morpholine in fish was calculated according to the following equation, consistent with CSA N288.6-12 (CSA, 2012):

$$\text{Dose (mg/kg-d)} = [\sum (C_{\text{food } i} \cdot IR_{\text{food } i} \cdot \text{RAF}_{\text{GIT}i} \cdot D_i)] \cdot D_4 / (\text{BW} \cdot 365 \cdot \text{LE})$$

where,

- $C_{\text{food } i}$ = concentration of contaminant in food i (mg/kg)
 $IR_{\text{food } i}$ = receptor ingestion rate for food i (kg/d)
 $\text{RAF}_{\text{GIT}i}$ = relative absorption factor from the gastrointestinal tract for contaminant i (unitless)
 D_i = days per year during which consumption of food i will occur (d/a)
 D_4 = total years exposed to site (years) (for carcinogens only)
 BW = body weight (kg)
 365 = total days per year (constant) (d/a)
 LE = life expectancy (years) (for carcinogens only)

3.2.4 Exposure Factors

3.2.4.1 Radiological Exposure Factors

For the radiological dose calculations the exposure factors (e.g., intake rates, occupancy and shielding factors, etc.) are generally those used in CSA N288.1-08. The intake rates for ingestion and inhalation are the mean intake rates provided in CSA N288.1-08 (2008) and Hart (2008) with the exception of the drinking water intake rate for a 1 year old infant. The drinking water intake rate for the 1 year old infant was adjusted from the default value in CSA N288.1-08 based on guidance in Clause 6.15.3.2, since the PN infant is assumed to drink only cow's milk (and not water and infant formula) (OPG, 2010b). Table 3.15 summarizes the exposure factors used in the radiological dose calculations.

Table 3.15: Human Exposure Factors for Radiological Dose Calculations

Exposure Factor	Units ⁽⁴⁾	Infant 1 year	Child 10 year	Adult
Inhalation rate	m ³ /a	1830	5660	5950
Inhalation occupancy factor	NA	1.0	1.0	1.0
Incidental soil ingestion rates	g dw/d	0.04	0.04	0.01
Incidental ingestion of sediment	g dw/d	0.04	0.04	0.01
Drinking water intake rates ⁽¹⁾	L/a	0	262.8	511
Aquatic animal intake rates ⁽²⁾	kg/a	0.58	1.97	4.6
Terrestrial animal intake rates	kg/a	249	234	256.6
Terrestrial plant intake rates	kg/a	120.5	275.1	465.9
Outdoor occupancy factor	NA	0.2	0.2	0.2
Indoor plume shielding factor (effective dose)	NA	0.5	0.5	0.5
Indoor plume shielding factor (skin dose and pure beta emitters)	NA	1.0	1.0	1.0

Exposure Factor	Units ⁽⁴⁾	Infant 1 year	Child 10 year	Adult
Indoor groundshine shielding factor (gamma emitters) ⁽³⁾	NA	0.2	0.2	0.2
Groundshine shielding factor (uneven surface shielding)	NA	0.5	0.5	0.5
Beach swim occupancy factor	NA	0	0.014	0.014
Bathing occupancy factor	NA	0.014	0.014	0.014
Pool swim occupancy factor (WSP fill)	NA	0	0.028	0.028
Pool swim occupancy factor (Well water fill)	NA	0	0.014	0.014
Skin area	m ²	0.72	1.46	2.19
Dilution factor for shoreline sediments	NA	1.0	1.0	1.0
Shore Width factor (lake)	NA	0.3	0.3	0.3
Shoreline occupancy factor	NA	0.02	0.02	0.02
No. days/a soil ingested	d/a	135	135	135
No. days/a sediment ingested	d/a	45	45	45

Notes:

- (1) The infant water intake rate is the difference between the water intake and milk intake rate given in CSA N288.1-08 factoring in the water content of milk.
- (2) Excludes shellfish due to fresh water environment at PN. Shellfish are a marine environment food product.
- (3) For effective and skin dose. For essentially pure beta emitters, this shielding factor is zero.
- (4) dw used in specification of units indicates dry weight.

3.2.4.2 Non-Radiological Exposure Factors

For non-radiological dose calculations, exposure factors are generally those from Health Canada Preliminary Quantitative Risk Assessment guidance (2004, 2010), as recommended by Clause 6.3.5 of CSA N288.6-12 (CSA, 2012). Table 3.16 summarizes the exposure factors used in the non-radiological dose calculations.

Based on the results of the screening, the human exposure assessment was performed for hydrazine for the inhalation pathway and the drinking water and fish ingestion pathways. Hydrazine is added to the feedwater for oxygen removal. Hydrazine is released into the atmosphere through boiler steam releases and venting. Hydrazine is discharged into the aquatic environment through boiler blowdown and flushing to the intake forebay. Boiler blowdown is generally continuous and intermittent at PN U5-8, and intermittent at PN U1-4. For this assessment it was assumed that hydrazine is released to the aquatic environment continuously.

Based on the results of the screening, the human exposure assessment was performed for morpholine for the drinking water and fish ingestion pathways. Morpholine is added to the feedwater for pH control. Morpholine is discharged into the aquatic environment through boiler blowdown and flushing to the intake forebay. For this assessment it was assumed that morpholine is released to the aquatic environment continuously.

Since the relevant exposure pathway for the Sport Fisher is through fish ingestion, the fish tissue concentration for the relevant COPCs was estimated using bioaccumulation factors (BAFs), as discussed below.

Limited data exist on the bioaccumulation of hydrazine in aquatic organisms. Slonim and Gisclard (1976) derived a bioconcentration factor (BCF) of 288 L/kg based on a hydrazine concentration (144 mg/kg) estimated in guppies after four days exposure to hard water at a hydrazine concentration of 0.5 mg/L. According to Environment Canada and Health Canada (EC/HC, 2011) there are limitations and uncertainties associated with this study. Hydrazine was not measured in the fish, but was estimated from measurements in water, assuming that the slightly greater loss from water over 4 days, when fish were in the water, was due to uptake into the fish. Hydrazine bioaccumulation in fish was not directly measured. Since the same study showed higher rates of hydrazine degradation due to fish excretia in water, it is not clear that any hydrazine uptake into fish actually occurred. As well, a hydrazine concentration of 0.5 mg/L can generate ecotoxicity; therefore, there is uncertainty around the BCF of 288 L/kg. According to the *Persistence and Bioaccumulation Regulations* under the *Canadian Environmental Protection Act*, hydrazine would not be considered a substance that bioaccumulates since its BAF (or BCF) is less than 5000 and its $\log K_{ow}$ is less than 5 ($\log K_{ow}$ of -2.07 (EC/HC, 2011)).

Considering the large uncertainty surrounding the Slonim and Gisclard (1976) study, the published BCF from that study was not used for the quantitative evaluation of hydrazine. Quantitative Structure-Activity Relationship (QSAR) models are available to estimate bioconcentration factors for chemicals using correlations between BCFs and hydrophobicity ($\log K_{ow}$), where experimental data on bioaccumulation are lacking (European Commission, 2006). Meylan et al. 1999 (as cited in European Commission, 2006) recommends an improved model that suggests using a $\log BCF$ of 0.5 for all non-ionic compounds with $\log K_{ow} < 1$. Therefore, a $\log BCF$ of 0.5 was used to represent bioaccumulation of hydrazine in fish.

No data exist on the bioaccumulation of morpholine in aquatic organisms; however, bioaccumulation is not expected based on its low octanol-water partition coefficient ($\log K_{ow}$ of -2.55) (BUA, 1991 as cited in WHO, 1996). According to the *Persistence and Bioaccumulation Regulations* under the *Canadian Environmental Protection Act*, a substance is considered to bioaccumulate if its $BAF \geq 5000$, or its $BCF \geq 5000$, or if the $\log K_{ow} \geq 5$ (if neither the BAF nor the BCF can be determined). Similar to hydrazine, a $\log BCF$ of 0.5 was used to represent bioaccumulation of morpholine in fish, based on the recommended QSAR models discussed above (Meylan et al. 1999; as cited in European Commission, 2006).

Table 3.16: Human Exposure Factors for Non-Radiological Dose Calculations

Parameter	Units	Urban Resident		Commercial/ Industrial Worker	Sport Fisher		Reference
		Toddler	Adult	Adult	Toddler	Adult	
Drinking Water Intake Rate	L/d	0.6	1.5	1.5	N/A	N/A	HC, 2010
Fish Ingestion Rate	kg/d	N/A	N/A	N/A	0.056	0.111	HC, 2004
Days per Week/7 (D2)	d/d	1	1	1	N/A	N/A	OPG, 2013b
Weeks per Year/52 (D3)	wk/wk	1	1	0.23	N/A	N/A	OPG, 2013b
Years Exposed (D4)	years	N/A	30	30	N/A	30	HC, 2004
D _{fish}	d/a	N/A	N/A	N/A	365	365	OPG, 2013b
Body Weight	kg	16.5	70.7	70.7	16.5	70.7	HC, 2010
Life Expectancy	years	N/A	70	70	N/A	70	
RAF _{GIT} hydrazine		1	1	1	1	1	conservative assumption
RAF _{GIT} morpholine		1	1	1	1	1	conservative assumption

Note:

Characteristics of the Urban Resident are also applicable to the Correctional Institution

3.2.5 Models

OPG uses IMPACT™ version 5.4.0 (IMPACT) to calculate its annual public radiological doses using a mixture of environmental monitoring data and emissions data. IMPACT represents the method of dose calculation presented in CSA N288.1-08 (2008). Where environmental monitoring data were lacking, the concentration of radionuclides in air was determined from the sector-averaged Gaussian plume atmospheric dispersion model in IMPACT, based on the release rates from PN. Table 3.17 shows a summary of which radionuclides and pathways were modelled and where measured data were used.

AERMOD was used by OPG (2015e) to estimate the hydrazine concentration in air at a number of locations at the PN site boundary. Results from AERMOD are reported in this risk assessment.

The MOECC approved model in the Appendix to O.Reg.346/90 was used to estimate maximum ½ hour concentrations of COPCs at the PN site boundary to support the ESDM (OPG, 2015e). Results are reported in this risk assessment.

Table 3.17: Radionuclide and Pathway Data Used in the Dose Calculations (OPG, 2016c)

Pathway	Radionuclide	Modeled ⁽¹⁾	Measured
Air Inhalation	Tritium	✓ (Fisher)	✓
	Tritium	✓ ⁽²⁾	
	Carbon-14	✓ ⁽²⁾	✓
	Iodine (mixed fission product)	✓ ⁽²⁾	
	Cobalt-60	✓ ⁽²⁾	
Air External Exposure	Noble Gas		✓ ⁽³⁾
	Carbon-14	✓ ⁽²⁾	✓
	Iodine (mixed fission product)	✓ ⁽²⁾	
	Cobalt-60	✓ ⁽²⁾	
Soil External Exposure	Tritium	✓	
	Carbon-14	✓	
	Iodine (mixed fission product)	✓	
	Cesium-137+, Cobalt-60	✓	
Sand External Exposure	Tritium	✓	
	Carbon-14	✓	
	Iodine (mixed fission product)I(mfp)	✓	
	Cesium-137+		✓
Water External Exposure (Lakes, WSPs, Wells)	Tritium	✓ (wells)	✓
	Carbon-14	✓	
	Iodine (mixed fission product)	✓	
	Cesium-137+	✓	
Terrestrial Animals Ingestion	Tritium	✓	✓ (milk, eggs, poultry)
	Carbon-14	✓	✓ (milk, eggs, poultry)
	Iodine (mixed fission product)	✓	
	Cesium-137+, Cobalt-60	✓	
	Organically Bound Tritium (OBT)	✓ ⁽⁴⁾	
Terrestrial Plants Ingestion	Tritium		✓
	Carbon-14		✓
	Iodine (mixed fission product)	✓	
	Cesium-137+, Cobalt-60	✓	

Pathway	Radionuclide	Modeled ⁽¹⁾	Measured
	Organically Bound Tritium (OBT)	✓ ⁽⁴⁾	
Aquatic Animals Ingestion	Tritium		✓
	Carbon-14		✓
	Iodine (mixed fission product)	✓	
	Cesium-137+		✓
	Organically Bound Tritium (OBT)	✓ ⁽⁴⁾	
Sand and Soil Incidental Ingestion	Tritium	✓	
	Carbon-14	✓	
	Iodine (mixed fission product)	✓	
	Cesium-137+, Cobalt-60	✓	✓ (sand)
	Tritium		✓
Water Ingestion (WSPs, Wells)	Carbon-14	✓	
	Iodine (mixed fission product)	✓	
	Cesium-137+	✓	

Notes:

“+” indicates that contributions from progeny are included.

(1) Modeling is based on emissions or from local air measurements where they are available

(2) Concentrations are modeled from emissions and adjusted using empirical K_a determined for each potential critical group location

(3) Doses are measured directly at the site boundary and adjusted to potential critical group locations using the ratio of modeled air dispersion factors for the boundary monitor and potential critical group

(4) OBT dose is modeled from tritium (HTO) concentration in terrestrial plants, terrestrial animals, or fish respectively.

3.2.6 Exposure Point Concentrations and Doses

3.2.6.1 Radiological Exposure Point Concentrations and Doses

Since 2013, the annual Radiological Environmental Monitoring Program report was changed to the annual EMP report entitled “Results of Environmental Monitoring Programs”. During this time, the EMP was redesigned to meet the requirements of CSA N288.4-10 (CSA, 2010) and expanded to include conventional contaminants, physical stressors and non-human biota; in addition to the radiological contaminants and human exposure.

For the radiological exposure assessment, exposure point concentrations are either based on measured data from the annual EMP or modelled from emissions data, as described in Table 3.17 and in OPG (2010b). Additionally, when measurement averages or other calculations are performed, they are calculated using actual results obtained even if they are below the critical level (OPG, 2010). As mentioned above, OPG uses IMPACT™

version 5.4.0 (IMPACT) to calculate its annual public doses using a mixture of environmental monitoring data and emissions data. Table 3.18 presents a summary of the maximum dose to the critical group from 2011 to 2015. The annual dose during the five year period of interest (2011 to 2015) ranged from 0.9 to 1.2 μSv and the critical group was the urban resident (adult). The dominant pathways and radionuclides that contribute significantly to the total dose are inhalation of tritium and external exposure to noble gases.

The dose to the critical group over the 2011 to 2015 time period remained relatively constant. In 2010 the critical group that received the highest dose switched from the Industrial/Commercial Worker to the Urban Resident. This change results from adjustments made to the characteristics of the Urban Resident to account for the portion of residents who work within 5 km of PN, resulting in increased dose from noble gases. The dose to the urban resident was slightly higher in 2012 than in 2011. This small difference is attributed to higher noble gas concentrations measured at boundary locations in 2012, as compared with 2011, due to a higher number of operating days of U1 and U4 in 2012.

Table 3.18: Summary of Dose to Critical Group from 2011 to 2015

Year	Critical Group	Effective Dose (μSv)	Percentage of Regulatory Limit (%)	Percentage of Dose from Canadian Background Radiation (%)
2011	Urban Resident (adult, 10 year old child)	0.9	0.1	0.1
2012	Urban Resident (adult)	1.1	0.1	0.1
2013	Urban Resident (adult)	1.1	0.1	0.1
2014	Urban Resident (adult)	1.2	0.1	0.1
2015	Urban Resident (adult)	1.2	0.1	0.1

3.2.6.1.1 Radiological Doses using Phosphorous-32 to Represent Gross Beta/Gamma in Water

The 2014 PN ERA (EcoMetrix, 2014) recommended assessment of a study to analyze phosphorous-32 in fish, since this is the limiting radionuclide for the waterborne beta/gamma Derived Release Limit (DRL). DRLs are intended to be conservative and inclusion of phosphorous-32 provides a conservative screening limit for gross beta/gamma activity in waterborne effluents. However, effluent characterization data from PN indicated that concentrations of phosphorous-32 in the effluent were at or below detection limits, which are lower than the dominant gamma emitters in active liquid waste, such as cesium-137 and cobalt-60. Based on this effluent data the likelihood of detecting phosphorous-32 in fish is extremely low and its short half-life presents analytical limitations. Cesium-137 and cobalt-60 are more suitable radionuclides to represent gross beta gamma radionuclides

released to the environment from PN operations. Currently fish are analyzed for cobalt-60, cesium-134, and cesium-137. This practice will continue as part of the routine EMP.

3.2.6.1.2 Radiological Doses from the PWMF

As described in Section 3.1.2.5.1, the fields outside the PWMF are due primarily to contributions from direct gamma radiation and secondarily from gamma skyshine. The Sport Fisher is the only critical group where gamma radiation fields from the PWMF would likely be measurable. Based on a study from 2000, at a distance of 500 m from the PWMF, the measured air kerma rate was below the detection limit of 0.13 nGy/h. At a distance of 1 km from the PWMF, the air kerma rate was estimated to be negligible.

The dose to the Sport Fisher based on full capacity is presented in Table 3.19, based on a 1% occupancy for the Sport Fisher at the outfall. The maximum total annual dose to the Sport Fisher from the PWMF (Phase I and II) at full PWMF capacity can be up to 0.14 μ Sv.

Table 3.19: Maximum Annual Dose to Sport Fisher from PWMF Phase I and Phase II

Site	Dose Rate (μ Sv/h) Full capacity (OPG, 2013a)	Annual Dose (μ Sv) Full capacity
PWMF Phase I	6E-04	5.26E-02
PWMF Phase II	9.7E-04	8.50E-02

3.2.6.2 Non-Radiological Exposure Point Concentrations and Doses

For the non-radiological exposure assessment, exposure point concentrations are based on the screening conducted during problem formulation, which concluded that hydrazine and morpholine required further assessment. For waterborne non-radiological COPCs, exposure point concentrations are based on measured data from the 2014 supplementary study (EcoMetrix, 2015) and the 2015 baseline environmental monitoring program. The dose to the Sport Fisher due to ingestion of fish exposed to hydrazine and morpholine assumes a continuous release. A large portion of the dataset for hydrazine and morpholine were non-detects, and these concentrations were evaluated at the detection limit.

CSA N288.6-12 recommends that in instances where there are non-detects in the dataset and they were not predominant (<15%), that they be replaced with a one-half MDL value. However, when more than 50% of the dataset is comprised of non-detects, there is no method to provide a reliable estimate of the mean (CSA, 2012). To be conservative, in these instances the detection limit was considered to be a measured value and was used in the dataset to calculate the mean, likely overestimating the concentrations found at the location.

The maximum and mean morpholine concentrations in the outfall were obtained from surface water samples collected in the vicinity of the PN outfalls from the 2015 baseline environmental sampling program. The maximum and mean morpholine concentrations at Ajax WSP were determined based on the surface water model developed for PN to support the Pickering Safe Storage Project activities (Golder and EcoMetrix, 2017). The combined dilution factor from the outfall (PN U1-4 and PN U5-8) to Ajax WSP was 42.

The maximum and mean hydrazine concentrations in the outfall were obtained from surface water samples collected in the PN outfalls during the 2014 supplementary study for hydrazine (EcoMetrix, 2015). The hydrazine concentration at Ajax WSP were determined based on the surface water model developed for PN to support the Pickering Safe Storage Project activities (Golder and EcoMetrix, 2017). The combined dilution factor from the outfall (PN U1-4 and PN U5-8) to Ajax WSP was 42.

For fish ingestion, the exposure concentration was determined using all of the measured lake water samples. For drinking water the exposure concentration was determined using only the measurements from the PN outfall stations and then applying appropriate dilution and decay rates for travel between the outfall and the WSP.

In EcoMetrix (2015), a dilution factor of 8, based on CSA N288.1 methodology, was used to estimate the hydrazine concentration at Ajax WSP. This is a conservative estimate, due to conservative assumptions in the CSA aquatic dispersion model, and its parameterization for DRL purposes. As described previously, a surface water model was developed for PN to support the Pickering Safe Storage Project activities (Golder and EcoMetrix, 2017). As such, the dilution factor used in EcoMetrix (2015) to determine the hydrazine exposure concentration at the Ajax WSP was modified using more realistic dilution factors developed for PN to support the Pickering Safe Storage Project activities.

At a pH of 8 (representative of the typical pH observed in Lake Ontario near PN), the chemical half-life of hydrazine ranges from 0.6 to 1.31 days (EC/HC, 2011). Conservatively using the longer half-life, and a dilution factor of 42 from the outfall to the Ajax WSP, the estimated exposure concentration at the Ajax WSP intake is 0.0029 µg/L.

For airborne non-radiological COPCs, the air concentrations at PN were estimated based on annual hydrazine emission rates from the facility and AERMOD dispersion modelling results (OPG, 2015e). The model used worst case hydrazine emissions (1.87E-03 g/s) during different operating conditions/scenarios (i.e., normal operating condition and unit start-ups) to predict annual hydrazine concentrations at a number of receptors along the property. Exposure concentrations for hydrazine were obtained from AERMOD results for the closest human receptors (Urban Resident, Sport Fisher, Industrial/Commercial Worker, and Correctional Institution) as those locations were within the modelling boundary. Exposure concentrations for the Farm and Dairy Farm were outside of the AERMOD modelling boundary, but are bound by the other human receptors evaluated. The exposure point concentrations for hydrazine in air are shown in Table 3.20. These concentrations

represent maximum annual average concentrations. Mean annual concentrations for hydrazine in air are not available.

A summary of the dose to receptors from exposure to hydrazine and morpholine in water through ingestion and from exposure to hydrazine in air through inhalation is presented in Table 3.21, Table 3.22, and Table 3.23.

Table 3.20: Summary of Exposure Point Concentrations for Relevant Receptors, Pathways and Non-Radiological COPCs

Location	Receptor	Media	COPC	Units	Max Annual Conc.	Mean Annual Conc.	Notes
Outfall (500mSouth)	Sport Fisher	Air	Hydrazine	µg/m ³	6.9E-04	N/A	2015 AERMOD Results – Max POI (OPG, 2015e)
		Water (fish ingestion)	Hydrazine	mg/L	0.00025	0.00008	Max of all 2014 samples, PNGSB NEAR in Figure 3.3 (EcoMetrix, 2015) Mean of all July 2014 samples (EcoMetrix, 2015) ¹
			Morpholine	mg/L	0.006	< 0.0041	Max of all 2015 lake water samples (LW-10 in Figure 3.2) Mean of all 2015 lake water samples
Ajax WSP	Industrial/Commercial Worker Urban Resident Correctional Institution	Water (ingestion)	Hydrazine	mg/L	0.0000047	0.0000017	Max of PN outfall 2014 samples (PNGSNEAR, PNGSMID, PNGSFAR, Figure 3.3), t _{1/2} = 1.3 days, dilution factor = 42 Mean of PN outfall July 2014 samples, t _{1/2} = 1.3 days, dilution factor = 42 ¹ (EcoMetrix, 2015)
			Morpholine	mg/L	0.00015	< 0.0001	Max and mean of 2015 PN samples near outfalls (LW-10, LW-21, LW-9, Figure 3.2), dilution factor = 42
0.95 km NNE	Industrial/Commercial Worker	Air	Hydrazine	µg/m ³	2.4E-04	N/A	2015 AERMOD Results – C3 (OPG, 2015e)
1.35 km WNW	Urban Resident	Air	Hydrazine	µg/m ³	8E-05	N/A	2015 AERMOD Results – R2 (OPG, 2015e)

Location	Receptor	Media	COPC	Units	Max Annual Conc.	Mean Annual Conc.	Notes
3.1 km NNE	Correctional Institution	Air	Hydrazine	µg/m ³	6E-05	N/A	2015 AERMOD Results – Estimated from Figure 3.1 (OPG, 2015e)

Note:

1. Hydrazine results were available for July, August, and September 2014. Mean was calculated from July 2014 results only as the majority of data from August and September were non-detects.

Table 3.21: Dose to Urban Resident and Commercial/Industrial Worker from Water Ingestion

COPC	Water Conc. From Ajax WSP (mg/L)		Urban Resident/ Correctional Institution Mean Dose (mg/kg-d)		Commercial / Industrial Worker Mean Dose (mg/kg-d)	Urban Resident/ Correctional Institution Max Dose (mg/kg-d)		Commercial / Industrial Worker Max Dose (mg/kg-d)
	Mean	Max	Toddler	Adult	Adult	Toddler	Adult	Adult
Hydrazine	0.0000017	0.0000047	N/A	1.50E-08	3.45E-09	N/A	4.27E-08	9.82E-09
Morpholine	<0.0001	0.00014	3.66E-06	2.13E-06	4.90E-07	5.26E-06	3.07E-06	7.06E-07

Notes:

The dose to the urban resident is also applicable to the correctional institution resident.

For carcinogenic substances only exposure to adult receptors is needed (HC, 2010). The toddler dose is not limiting and was not calculated.

Table 3.22: Dose to Sport Fisher due to Fish Ingestion

COPC	Water Conc. for Sport Fisher (mg/L)		BAF (L/kg fw)	Fish Tissue Conc. (mg/kg fw)		Sport Fisher Mean Dose (mg/kg-d)		Sport Fisher Max Dose (mg/kg-d)	
	Mean	Max		Mean	Max	Toddler	Adult	Toddler	Adult
Hydrazine	0.00008	0.00025	3.16	0.0003	0.0008	N/A	1.70E-07	N/A	5.32E-07
Morpholine	<0.0041	0.006	3.16	0.0129	0.0190	4.39E-05	2.03E-05	6.43E-05	2.98E-05

Notes:

The BAF is from Meylan et al. 1999 (as cited in European Commission, 2006) that suggests using a logBCF of 0.5 for all non-ionic compounds with logK_{ow} < 1.

For carcinogenic substances only exposure to adult receptors is needed (HC, 2010). The toddler dose is not limiting and was not calculated.

Table 3.23: Dose to Receptors due to Hydrazine Inhalation

Receptor	Fraction of Time Exposed	Mean Dose ($\mu\text{g}/\text{m}^3$)	Max Dose ($\mu\text{g}/\text{m}^3$)
Urban Resident	1	-	2.74E-05
Industrial/Commercial	0.23	-	1.89E-05
Fisher	0.01	-	2.37E-06
Correctional Institution	1	-	2.06E-05

Note:

Includes 80% reactor capacity assumption

Mean dose is not presented as mean annual hydrazine concentrations in air are not available.

3.2.7 Uncertainties in the Exposure Assessment

Table 3.24 summarizes the major uncertainties and assumptions in the exposure assessment.

Table 3.24: Summary of Major Uncertainties in the Exposure Assessment

Risk Assessment Assumption	Justification	Over/Under Estimate Risk?
Water concentration for hydrazine and morpholine at Ajax WSP is pre-treatment, and is modeled from liquid releases	Hydrazine degrades rapidly under chlorinated conditions typically used for treatment/distribution of drinking water (EC/HC, 2011). No information on concentration of other COPCs post WSP treatment, dilution factor available from PN to Ajax WSP	Neither (Morpholine) Overestimate (Hydrazine)
Average dilution factors from the surface water model were used to estimate water concentrations at the Ajax WSP	Based on maximum and minimum lake water conditions the dilution factors from PN to Ajax WSP can range from 14 to 873, with an average dilution factor of 42.	Neither
Mixed beta-gamma emissions to air (particulate) are represented by cobalt-60 and mixed beta-gamma emissions to water are represented by cesium-137.	These radionuclides are the radionuclides with the most limiting dose based on DRL calculation.	Overestimate
BAF for hydrazine is based on QSAR model and not measured bioaccumulation data.	Limited information exists on bioaccumulation of hydrazine, although it is expected to be low. Only one study (Slonim and Gisclard, 1976) exists on hydrazine bioaccumulation, and there is large uncertainty surrounding the methods and results.	Neither (value is best estimate)

Risk Assessment Assumption	Justification	Over/Under Estimate Risk?
BAF for morpholine is based on QSAR model and not measured bioaccumulation data.	No information in literature regarding morpholine BAF, although it is not expected to bioaccumulate.	Neither (value is best estimate)
Biodegradation of hydrazine was not taken into account for air	Conservative assumption	Overestimate

3.3 Toxicity Assessment

3.3.1 Toxicological Reference Values (TRVs)

A summary of the TRVs selected for hydrazine and morpholine are presented in Table 3.25 and discussed below. Examples of TRVs include slope factors and unit risks for carcinogens, and reference doses, tolerable daily intake, or acceptable daily intake for non-carcinogens. TRVs are used in the risk characterization to determine ILCRs and Hazard Quotients (HQs), as discussed in Section 3.4

Hydrazine is classified by the International Agency for Research on Cancer (IARC) and the US EPA as a Group 2B carcinogen – probable human carcinogen; and by the European Commission as Category 2 for carcinogenicity – should be regarded as if it is carcinogenic to man. Studies showed tumor induction in mice, rats and hamsters following administration of hydrazine orally or via inhalation (EC/HC, 2011).

The inhalation unit risk for hydrazine is $4.9E-03 (\mu\text{g}/\text{m}^3)^{-1}$ and was derived by the US EPA based on a 1981 study by MacEwan et al. of nasal cavity tumors in rats exposed to hydrazine via inhalation (US EPA, 1991). The US EPA (1991) has derived an oral slope factor of $3.0 (\text{mg}/\text{kg}\cdot\text{day})^{-1}$ based on a 1970 study by Biancifiori on liver cancer in mice exposed to hydrazine sulphate orally.

Morpholine is not carcinogenic or teratogenic; however, morpholine can be nitrosated to n-nitrosomorpholine which is carcinogenic. Health Canada (2002) has derived an acceptable daily intake of 0.48 mg/kg/d based on a No Observable Adverse Effect Level (NOAEL) from a chronic oral toxicity study conducted by Shibata et al. (1987) in rats and mice, with the inclusion of uncertainty factors (UFs). Specifically, a UF of 10 was used for the inter-species differences between mice and humans, and a second UF of 10 was used for the intra-species differences between humans. Additionally, a UF of 2 was included to reflect the deficiencies in the toxicological database (J. Rotstein, personal communication, December 27, 2013).

Table 3.25: Selected Human Toxicity Reference Values for Non-Radiological Risk Assessment

COPC	TRV Type	Value	Units	Reference
Hydrazine	Oral Slope Factor	3	(mg/kg/d) ⁻¹	IRIS US EPA, 2001 (as cited in US EPA, 2009)
	Inhalation Unit Risk	4.90E-03	(µg/m ³) ⁻¹	IRIS US EPA, 2001 (as cited in US EPA, 2009)
Morpholine	Acceptable Daily Intake	0.48	mg/kg/d	HC, 2002

3.3.2 Radiation Dose Limits and Targets

The public dose limit for radiation protection is 1 mSv/a, as described in the Radiation Protection Regulations under the *Nuclear Safety and Control Act*. This limit is defined as an incremental dose. It is set at a fraction of natural background exposure to radiation. Public doses arising from licensed facilities are compared to the public dose limit and higher doses are considered unacceptable.

3.3.3 Uncertainties in the Toxicity Assessment

The oral slope factors are developed as conservative upper-bound estimates of the increase in carcinogenic risks due to lifetime exposure to the COPC. The unit risk is the upper bound of the increase in carcinogenic risk estimated for continuous lifetime exposure to a chemical at a concentration of 1 µg/m³ in air. Unit risks and slope factors are used to estimate an upper bound probability of an individual developing cancer as a result of exposure to a particular level of a potential carcinogen. The unit risk and the slope factor are based on the assumption of a linear low-dose response. This is considered conservative. The acceptable daily intake for morpholine incorporates several UFs. Specifically, a UF of 10 was used for the inter-species differences between mice and humans, and a second UF of 10 was used for the intra-species differences between humans. Additionally, a UF of 2 was included to reflect the deficiencies in the toxicological database (J. Rotstein, personal communication, December 27, 2013). These factors are intended to provide a conservative toxicity reference value.

3.4 Risk Characterization

3.4.1 Risk Estimation

In order to characterize potential risks quantitatively, the results of the exposure and toxicity assessments were used to estimate HQs and ILCRs for each receptor. HQs were estimated for non-carcinogenic substances using a threshold TRV as follows:

$$\text{Hazard Quotient} = \text{Estimated Exposure} / \text{Toxicity Reference Value}$$

These HQs were compared to an acceptable value of less than 0.2, as recommended by Clause 6.5.2.6 in CSA N288.6-12.

For carcinogenic substances, the estimated exposure was multiplied by the appropriate non-threshold TRV, either a slope factor or a unit risk, to derive a conservative estimate of the potential ILCR, as follows:

$$\text{ILCR} = \text{Estimated Exposure} \times \text{Cancer Slope Factor}$$

Or, in the case of airborne contaminants:

$$\text{ILCR} = \text{Estimated Exposure} \times \text{Cancer Unit Risk}$$

The estimated ILCRs were compared to an acceptable cancer risk of less than 1 in 1,000,000 or 10^{-6} , as recommended by Clause 6.5.2.4 in CSA N288.6-12. This level is consistent with the acceptable risk level used by the Ontario MOE (2011) and the US EPA (2005). At this risk level, health impacts are considered to be negligible. Other agencies, such as Health Canada use a target cancer risk of less than 1 in 100,000 or 10^{-5} . However, a range of cancer risk between 1 in 10,000 and 1 in 1,000,000 is generally considered acceptable (Health Canada, 2004).

A summary of the HQs and ILCRs is presented in Table 3.26. The HQs and ILCRs are calculated according to the equations described above. The estimated exposures are from Table 3.21, Table 3.22, and Table 3.23 in the exposure assessment in Section 3.2. The TRVs used are those from Table 3.25 in the toxicity assessment in Section 3.3.

For radionuclides, the total dose is compared to the public dose limit of 1 mSv/a as discussed in Section 3.3.2 above.

Table 3.26: Risk Estimates for Exposure to COPCs

Receptor	Pathway	Type	COPC	Mean Risk	Max Risk	Acceptable Value
Urban Resident	Inhalation	ILCR	hydrazine	N/A	1.34E-07	1.00E-06
	Water Ingestion	ILCR	hydrazine	4.50E-08	1.28E-07	1.00E-06
	Water Ingestion	HQ	morpholine	0.00	0.00	0.2
Commercial/ Industrial Worker	Inhalation	ILCR	hydrazine	N/A	9.27E-08	1.00E-06
	Water Ingestion	ILCR	hydrazine	1.04E-08	2.94E-08	1.00E-06
	Water Ingestion	HQ	morpholine	0.00	0.00	0.2
Sport Fisher	Inhalation	ILCR	hydrazine	N/A	1.16E-08	1.00E-06
	Fish Ingestion	ILCR	hydrazine	5.10E-07	1.59E-06	1.00E-06
	Fish Ingestion	HQ	morpholine	0.00	0.00	0.2
Correctional Institution Resident	Inhalation	ILCR	hydrazine	N/A	1.01E-07	1.00E-06
	Water Ingestion	ILCR	hydrazine	4.50E-08	1.28E-07	1.00E-06
	Water Ingestion	HQ	morpholine	0.00	0.00	0.2

Note:

Grey shading and bold indicates when the risk exceeds the associated acceptable risk value. ILCR < 1.00E-06, HQ < 0.2.

Mean risk for hydrazine inhalation is not applicable since mean annual concentrations for hydrazine in air are not available

3.4.2 Discussion of Chemical and Radiation Effects

3.4.2.1 Effects Monitoring Evidence

Two studies of health indicators in Durham Region (Durham Region Health Department, 1996, 2007) compared the incidence of cancer deaths and birth defects for Durham Region, and for municipalities within Durham Region including Ajax-Pickering, Oshawa-Whitby, Clarington, and North Durham against the same statistics for the Province of Ontario. In the 1996 study, Halton Region and Northumberland were used for comparison purposes and in the 2007 study Halton Region and Simcoe County were used for comparison against

Durham Region. Both studies found no evidence that any emissions from CANDU stations at PN or Darlington Nuclear Generating Station had any adverse health effects on nearby residents.

3.4.2.2 Likelihood of Effects

A summary of the HQs and ILCRs are presented in Table 3.26.

As shown in Table 3.26, risks from modelled morpholine for the urban resident, correctional institution resident and industrial/commercial worker through water ingestion (Ajax WSP) are below the acceptable risk level of 0.2 for non-cancer risk, indicating that no increased risk from water ingestion is expected. With respect to the sport fisher, risks from morpholine through fish ingestion are below the acceptable risk level of 0.2 for non-cancer risk, indicating that no increased risk from fish ingestion is expected. The fish tissue concentration was estimated based on measured morpholine concentrations in the PN outfalls, and an assumed BAF for morpholine.

As shown in Table 3.26, risks from modelled hydrazine for the urban resident, correctional institution resident and industrial/commercial worker through water ingestion (Ajax WSP), are below the acceptable cancer risk level of 10^{-6} for both maximum and mean modelled hydrazine concentrations.

Exposure to the mean hydrazine concentration for the sport fisher through fish ingestion is below the acceptable cancer risk level of 10^{-6} . Since fish are mobile, exposure to the mean hydrazine concentration is more realistic than exposure to the maximum. The maximum would be above the acceptable cancer risk level of 10^{-6} . The maximum risk estimated is conservative. The fish tissue concentration was estimated based on measured hydrazine concentrations in the PN outfalls, and an assumed BAF for hydrazine.

As seen in Table 3.26, the estimated risk to the urban resident and the commercial/industrial worker from inhalation of hydrazine is below the acceptable cancer risk level of 10^{-6} . The risk estimates to the Urban Resident and Correctional Institution were $1.34\text{E-}07$ and $1.01\text{E-}07$, respectively. These risk estimates are based on updated modelling results for hydrazine in air using AERMOD (OPG, 2015e). The modelling results represent a worst-case hydrazine emissions scenario, but reduce some of the conservatism used in the 2014 ERA for the hydrazine assessment. The farm and dairy farm receptors were outside of the AERMOD modelling boundary, but are bound by the other human receptors evaluated.

In the 2014 ERA, the air concentrations at receptor locations were estimated using the dispersion factors used for the derived release limits and annual EMP dose calculations.

Risks at all receptor locations assessed due to inhalation of hydrazine are considered acceptable.

3.4.2.3 Radiation Effects

The public dose estimates for the critical group (industrial/commercial worker or the urban resident) are approximately 0.1% of the regulatory public dose limit of 1 mSv/a and approximately 0.1% of the dose from Canadian background radiation. Since the critical group receives the highest dose from PN, demonstration that they are protected implies that other receptor groups near PN are also protected.

The Sport Fisher may receive a maximum dose up to 0.14 $\mu\text{Sv/a}$ from exposure to the PWMF (Phase I and Phase II) at full capacity. The dose to the Sport Fisher from existing PN operations is approximately 0.3 $\mu\text{Sv/a}$ (OPG, 2012d); therefore the total dose from PN operations and the PWMF may be up to 0.44 $\mu\text{Sv/a}$; however, this is still a small fraction of the regulatory public dose limit.

Facility releases are considered to be adequately controlled, and further optimization of PN operations is not required. Nevertheless, the ALARA principle is applied at PN to reduce emissions as low as reasonably possible.

Since the dose estimates are a small fraction of the public dose limit and natural background exposure, no discernable health effects are anticipated due to exposure of potential groups to radioactive releases from PN.

3.4.2.4 Noise Effects

The Acoustic Assessment Report (OPG, 2011c) prepared for PN demonstrate that PN operates in compliance with applicable MOECC noise limits. The 2011 Acoustic Assessment Report was subsequently reviewed and approved by the MOECC. In issuing the ECA for PN (OPG, 2015f), the MOECC verified that the findings of the Acoustic Assessment Report adequately demonstrate that PN does not cause a substantial noise impact at the identified PORs.

Although there are periods of recorded maximum sound levels above the MOECC NPC 300 Class 1 and Class 2 sound level limits, site observations indicate these are unlikely to be directly associated with PN activities. These elevated sound levels are likely the result of localized events such as road traffic or human activity in the vicinity of the noise monitoring locations. It is common for noise levels in populated urban areas, such as near the PN site, to occasionally exceed the applicable prescribed sound level limit. As these occasional periods of elevated sound levels are not likely associated with PN activities, it is not expected that noise from PN activities is having a direct adverse effect on human receptors near the PN site.

3.4.3 Uncertainties in the Risk Characterization

There is inherent uncertainty in the air model in IMPACT that is used by OPG to estimate atmospheric dispersion factors to the critical group locations. Uncertainty in the air predictions arises from the following assumptions made in the model (Hart, 2008):

- The activity in the plume has a normal distribution in the vertical plane.
- The effects of building-induced turbulence on the effective release height and plume spread have been generalized, while data suggest that effects of building wakes vary substantially depending upon the geometry of the buildings and their orientation with respect to wind direction.
- A given set of meteorological and release conditions leads to a unique air concentration, where in reality measured concentrations can vary by a factor of 2 under identical conditions.

At distances greater than 1 km, there is a two-fold uncertainty around the predictions of the sector-averaged Gaussian model used in IMPACT (Hart, 2008). At all distances, the Gaussian air model in IMPACT on average, overpredicts air concentrations by approximately a factor of 1.5 (Hart, 2008). Considering the combined uncertainties in the exposure assessments and the target values, it is reasonable that the overall risks presented are conservative estimates.

A probabilistic risk assessment to quantify uncertainty in the risk estimate has not been performed and is not considered necessary, since it is not likely to provide a better basis for risk management/decision making. According to CSA N288.6-12 (CSA, 2012), a qualitative or semi-quantitative evaluation of uncertainty is considered sufficient for evaluation of uncertainty.

4.0 ECOLOGICAL RISK ASSESSMENT

4.1 Problem Formulation

The EcoRA focuses on the PN site and surrounding area, as shown in Figure 4.1. The assessment has been divided into nearshore Lake Ontario (generally in the area surrounding the PN outfalls), the PN site, and Frenchman's Bay.



Figure 4.1: Area of Assessment for Ecological Risk Assessment

4.1.1 Receptor (VEC) Selection and Characterization

4.1.1.1 Receptor (VEC) Selection

It is an impractical task to assess the effect of radiological and non-radiological emissions on all the species of biota within the natural ecosystem on the PN site. Therefore, a select group of organisms are chosen for dose and risk analysis. These organisms are selected because they are known to exist on the site, represent major taxonomic/ecological groups, represent major pathways of exposure, or have a special importance or value. These organisms are also known as valued ecosystem components (VECs). The model used for assessment of dose and risk is either specific to the selected VEC species, or is a more generic biota assessment model that is appropriate to a number of VECs with similar exposure characteristics.

VECs were selected in previous ecological assessments for the PN site in 2000 (SENES, 2000) and 2007 (SENES, 2007a). For the 2000 ERA, VECs were selected based on a review of biota found on or near the site, and multi-stakeholder input. In 2007, the VEC list was revised, with rationale provided. The ecological receptors from the two ERAs, along with their rationale, and recent data regarding biota, flora and fauna were reviewed and considered based on the criteria listed in Table 7.1 of CSA N288.6-12 (CSA, 2012), to arrive at an appropriate selection of VECs for this EcoRA. Table 4.1 presents the assessment considering the CSA criteria.

VECs were selected as receptors for the conceptual model based on the criteria in Table 4.1 (the species listed in bold were selected as VECs). Potential VEC species were selected to represent each major plant and animal group, reflecting the main ecological exposure pathways, feeding habits and habitats at or around the site. The list of receptors was reduced based on evaluation against the remaining criteria, using the previous rationale and other literature resources. Species that were ecologically similar to other species and could be represented by another species, were not included in the assessment to reduce redundancy in the exposure calculations. For example, the alewife and emerald shiner are similar across all criteria, and could be assessed interchangeably. However, according to impingement reports, the alewife is the dominant species impinged at PN, so it was chosen to be a receptor. Any effects on the alewife are considered representative of those for the emerald shiner. Further description regarding the chosen VECs, such as habitat and feeding habits, are provided in Appendix B.

Table 4.2 shows the VECs chosen for assessment and the assessment models used in estimating their COPC exposure, dose and risk. Nine species of fish were chosen as VECs to represent the fishes likely to be influenced by the operation of PN. However, due to the limited species-specific exposure factor and toxicity data available, risks to fish are estimated by assessing the fish in two categories (bottom-dwelling fish and pelagic fish) for the radiological assessment, and as one category (all fish) for the non-radiological assessment, using generic exposure and dose assessment models. When measured data

were available fish were assessed at the species level and not as a generic category. Similarly, a generic exposure and dose assessment model was applied for all terrestrial plants using generic bioaccumulation factors and toxicity reference values.

A fish model is used for assessment of frogs because the sensitive life stages for frogs (i.e., egg and tadpole) are aquatic and similar to the sensitive life stages for fish. For example, during the tadpole stage, tadpoles and fish have similar exposure pathways (e.g., absorption through skin and gills). In addition, exposure factor and toxicity data for amphibians are limited. Therefore, the fish assessment model is considered to be appropriate for frogs during their sensitive life stages.

A fish model is also used for assessment of turtles, since there is a lack of exposure factor and toxicity data for turtles. Both organisms reside in water, and they share similar exposure pathways.

Protection of the VECs implies that other species in the same taxonomic ecological group or VEC category are also protected.

Table 4.1: Criteria to Select Ecological Receptors (VECs)

VEC Category	Species (Potential VEC)	Major Plant or Animal Group	Facility or Stakeholder Importance	Socio-economic/ecological Significance	Availability of Information	Exposed to and/or Sensitive to Stressor	Potential to Evaluate Population Effects
Bottom Feeding Fish	Brown Bullhead	B	EW, PN		EER	W, R, NR, TH, IM	
	Round Whitefish	B, O	PN	CF	EER	W, R, NR, TH, IM	EER
	White Sucker	B	EW, PN		EER	W, R, NR, TH, IM	
	American Eel	B, FF	PN	E, T		W, TH, IM, NR	
Pelagic Fish	Alewife	P, F	PN			W, TH, IM, NR	
	Smallmouth Bass	P, PR	PN	SF	EER	W, R, NR, TH, IM	EER
	Northern Pike	P, PR, FF	PN	SF	EER	W, R, NR, TH, IM	EER
	Emerald Shiner	P, F	PN			W, TH, IM, NR	
	Lake Trout	P, PR, FF	PN	CF, SF		W, TH	
	Walleye	P, PR	PN	CF, SF		W, TH	
Aquatic Plants	Narrow-leaved cattail	Aquatic Plant	PN		EER	W, NR, R	
Aquatic Invertebrates	Benthic Invertebrates	Benthic Invertebrate	PN		EER	W, NR, R	
Terrestrial Invertebrates	Earthworms	Terrestrial Invertebrate	PN			A, NR, R	
Amphibians and Reptiles	Northern Leopard Frog	Amphibian	PN			A, W, NR, R	
	Midland Painted Turtle	Reptile	PN			A, W	

Riparian Birds	Lesser Scaup	AQ, AP, B			EER	EER		
	Double-Crested Cormorant	AQ, FF	PN		EER	EER		
	Trumpeter Swan	AQ, AP	RG, EW, PN		EER	BR, NR, NO	EER	
	Ring-billed Gull	TR, AQ, FF, IN, MM	PN		EER	R, A		
	Black-crowned Night Heron	AQ, FF	PN					
	Least Bittern	AQ, FF	PN	T				
	Common Tern	AQ, FF, IN	PN			R, NR, BR		
	Bufflehead	AQ, B, FF	PN			WC, SC, M,		
Terrestrial Birds	Great Horned Owl	TR, MM, BB	PN		EER	R, A		
	Grey Catbird	TR, IN	PN			A, BR, R, NR, NO		
	Red-winged Blackbird	TR, IN, SE	PN			R, A, BR, NR, NO		
	Red-tailed Hawk	TR, MM, IN, BB	PN			BR, NR, NO		
	Barn Swallow	TR, IN	PN	T		NR, R, A		
	Peregrine Falcon	TR, MM, BB	PN			R, A, BR		
Riparian Mammals	Muskrat	AM, AP, B	PN		EER	NR	EER	
Terrestrial Mammals	Red Fox	TM, MM, BB, PR, V	PN		EER	HM	EER	
	Meadow Vole	TM, V	EW, PN		EER			
	Woodchuck	TM, V	PN			NR, NO		
	Pines	Coniferous	EW, PN		EER	NR	EER	
Terrestrial Plants	Chokecherry	Shrub	PN			NR		
	New England aster	Herbaceous perennial	PN			NR		
	Eastern hemlock	Coniferous	PN			NR, R		
	Red ash	Deciduous	PN			NR		
	Sandbar willow	Shrub	PN			NR		
	Butternut	Deciduous	PN	E		NR		
<p>A – Affected by airborne emissions AM – Aquatic Mammal AP – Aquatic Plants in Diet AQ – Aquatic Bird B – Benthic Invertebrates in Diet BB – Birds in Diet BR – Breeds within the area CF – Commercial Fish E – Endangered EER – Identified as fulfilling requirement in EER (2000) EW – Identified in a scientific workshop for the 2000 ERA, included participants from OPG, CNSC, MOE, and consultants</p>			<p>F – Forage FF – Fish in Diet HM – Sensitive to human activities IM – Impingement Concern IN – Insects in Diet MM – Mammals in Diet M – Migratory NO – Sensitive to noise disturbance NR – Sensitive to Non-Radioactive emissions O – Omnivore P – Pelagic PN – Present on site</p>			<p>PR – Predator RG – Identified by the regulator (CNSC) R – Sensitive to Radioactive emissions SC – Exposed to sediment contamination SE – Seeds in Diet SF – Sport Fish T – Threatened TH – Sensitive to thermal emissions TM – Terrestrial Mammal TR – Terrestrial Bird V – Vegetation in Diet W – Affected by waterborne emissions WC – Exposed to water contamination</p>		

Note:

Species in bold were selected as VECs for the EcoRA.

Table 4.2: Summary of VECs and their Assessment Models used in the EcoRA

VEC Category	Assessment Model	VEC
Fish	Bottom Feeding Fish	Brown Bullhead
		Round Whitefish
		White Sucker
		American Eel
	Pelagic Fish	Alewife
		Smallmouth Bass
		Lake Trout
		Walleye
		Northern Pike
Amphibians and Reptiles	Bottom Feeding Fish	Northern leopard frog
		Midland painted turtle
Aquatic Plants	Aquatic Plant	Narrow-leaved cattail
Aquatic Invertebrates	Benthic Invertebrate	Benthic Invertebrates
Riparian Birds	Trumpeter Swan	Trumpeter Swan
	Ring-billed Gull	Ring-billed Gull
	Common Tern	Common Tern
	Bufflehead	Bufflehead
Riparian Mammals	Muskrat	Muskrat
Terrestrial Plants	Terrestrial Plants	Chokecherry
		New England aster
		Eastern hemlock
		Red ash
		Sandbar willow
		Pine/Grass
Terrestrial Invertebrates	Soil Invertebrate	Earthworms
Terrestrial Birds	Red-winged Blackbird	Red-winged Blackbird
	Red-tailed Hawk	Red-tailed Hawk
Terrestrial Mammals	Red Fox	Red Fox
	Meadow Vole	Meadow Vole

Note:

¹ Species in bold in Table 4.1 were selected as VECs. Table 4.2 indicates their VEC category, and the dose assessment model that was used to estimate their COPC exposures.

Flying insects may be adult forms of aquatic insects or terrestrial insects, the latter consisting of those insects that emerge from soil and those that spend their early life stages on foliage. The relative abundance of each will vary with location and time of the year. In this ERA, the Red-winged Blackbird was selected to represent a terrestrial insectivorous

bird species. The Red-winged Blackbird is assumed to consume earthworms because data for the flying insect to bird pathway is limited whereas that for the earthworm to bird is much better defined. Further, the consumption of earthworms by the Red-winged Blackbird instead of flying insects is a conservative approach since earthworms generally have higher contaminant concentrations than adult (flying) insects.

4.1.1.2 Consideration of Species at Risk

A review of all flora and fauna identified in the PN Site Study Area (TRCA, 2009a, OPG, 2016a) was performed against the Species at Risk in Ontario (SARO) list, the SARA list (Schedule 1) and the COSEWIC list for threatened or endangered species. Consistent with the information presented in Sections 2.3.5 and 2.3.6, a number of threatened and endangered species have been identified within the PN Site Study Area during the 2011 to 2015 time period, as shown in Table 4.3. Many of these species can be assessed using representative species already selected for the EcoRA.

Butternut was identified in TRCA (2009a) as being located in the Fresh-Moist Sugar Maple – Hemlock Mixed Forest environmental land classification (ELC); and the presence of butternut trees was last identified on the PN site in 2013 in Kinsmen Park (OPG, 2016c). Red Ash is also a deciduous tree and can represent butternut in the assessment.

Several of the buildings on-site may provide a suitable habitat for the Barn Swallow. These are not ground based locations and not considered a concern for direct soil contact of these receptors.

The Red-winged Blackbird was selected as a representative species for all terrestrial insectivores, and would conservatively represent Barn Swallow.

Least Bittern was last observed on the PN site in 2013 (OPG, 2016c). The Common Tern can represent the Least Bittern in the assessment as a riparian bird that ingests fish and insects.

Table 4.3: Representative Species for Identified Species at Risk

Species at Risk (Common and Scientific Name)	Federal and Provincial Status	Representative Species	Last Observed (OPG, 2016a)
Barn Swallow (<i>Hirundo rustica</i>)	threatened (federal and provincial)	Red-winged Blackbird (<i>Agelaius phoeniceus</i>)	2015
Least Bittern (<i>Ixobrychus exilis</i>)	threatened (federal and provincial)	Common Tern (<i>Sterna hirundo</i>)	2013
Butternut (<i>Juglans cinerea</i>)	endangered (federal and provincial)	Red ash (<i>Fraxinus pennsylvanica</i>)	2013
American Eel (<i>Anguilla rostrata</i>)	endangered (provincial), threatened (federal)	American Eel (<i>Anguilla rostrata</i>)	2015

Note:

These species at risk have been identified during the 2011 to 2015 period.

4.1.1.3 Receptor (VEC) Characterization

Receptor profiles in Appendix B describe the habitat and the feeding habits of the selected receptor species. The receptor species were assigned to assessment locations on the site based on habitat features at each location and where the receptor is likely to be found. Receptor locations for assessment purposes are discussed in Section 4.1.5.

For mammals and birds, dietary assumptions were made based on the described feeding habits. Diets were simplified to represent the main food chain pathways without trying to capture their full taxonomic complexity. For example, muskrats are assumed to eat aquatic plants. Additionally, although some species may primarily eat insects (i.e., Red-winged Blackbird), earthworm is used as a surrogate for all insects and invertebrates, since limited data are available for insects and other invertebrates. The dietary assumptions for bird and mammal receptors are detailed in Table 4.16.

Species-specific exposure parameters, including bioaccumulation factors, food and water ingestion rates, transfer factors and body weights, are described Section 4.2.3.4.

4.1.2 Assessment and Measurement Endpoints

Assessment endpoints are attributes of the receptors to be protected in environmental programs (Suter *et al.*, 1993). The purpose of an environmental risk assessment is to evaluate whether these environmental protection goals are being achieved or are likely to be achieved. The assessment endpoint for all receptors in this ecological risk assessment is population abundance. The environmental protection goal is to maintain population abundance for the majority of species, and thereby maintain ecosystem function. The purpose of the ecological risk assessment is to evaluate whether this goal is likely to be achieved.

The assessment endpoint for the identified species at risk will be the individual, as recommended in Clause 7.2.4.3 of CSA N288.6-12 (CSA, 2012), since effects on even a few individuals of species at risk would not be acceptable.

Population abundance will not be directly measured or predicted quantitatively in this ecological risk assessment. Forecasting stressor effects on population abundance requires development and parameterization of a population model which incorporates understanding of stressor effects and compensatory mechanisms. This understanding requires years of population study, which is beyond the scope of the EcoRA at present.

Measurement endpoints are typically utilized to evaluate whether environmental protection goals are likely to be achieved. These are endpoints such as reproduction, growth and survival that are logically related to maintenance of population abundance, but are more easily inferred from COPC concentration and dose. In this EcoRA, possible effects of COPCs on survival or reproduction will be inferred or predicted by comparison of estimated

doses to benchmark doses that have been associated with such effects in the literature. The benchmark values used are presented in Section 4.3.

4.1.3 Selection of Chemical, Radiological, and Other Stressors

The same monitoring data sources previously screened for the HHRA (Section 3.1.2) were screened for the EcoRA using the more conservative of available federal and provincial guidelines and objectives as screening criteria. If there was no such guideline or objective, screening criteria were obtained from the literature, and/or derived using federally and/or provincially accepted methods. For COPCs where these criteria are not available, upper estimates of background concentrations or conservative toxicity benchmarks (e.g., no effects levels) are used as screening criteria. Maximum measured concentrations of parameters in surface water, sediment, soil, and air are compared to the selected screening criteria in order to determine the list of COPCs. Contaminants are also retained as COPCs if no screening criteria are available.

Selected radiological stressors are considered of public interest and therefore are carried forward quantitatively in the EcoRA and do not undergo a formal screening assessment. The relevant radionuclides that are the focus of the quantitative assessment are described in the following subsections.

4.1.3.1 Chemical COPCs in Air

Section 3.1.2.1 describes the atmospheric releases due to the operations at the PN site. As per clause 7.3.4.2.5 in CSA N288.6-12, inhalation exposures to biota are usually minor compared to the soil and food ingestion pathways, and can be ignored for most substances, except for substances that do not partition to soil (CSA, 2012). These substances may include gases such as nitrogen oxides, sulphur dioxide, hydrazine, and morpholine, as for these substances air concentrations dominate the exposure pathway to terrestrial biota. For completeness, all chemicals identified in the ESDM (OPG, 2015e) have been screened against relevant ecological benchmarks (Appendix A, Table A.14). The MOECC AAQC has been used as the preferred screening level as AAQCs are developed to be protective of health and the environment. Where AAQCs were not available other screening levels such as ESLs from the Texas Commission on Environmental Quality (TCEQ, 2015) were used. ESLs are based on data for health effects, odour and effects on vegetation and can therefore be applied as ecological screening levels.

The maximum POI concentrations at the PN property line (see Figure 2.7) for NO_x and SO_x were predicted using estimated atmospheric emissions and a dispersion factor. The ½ hour POI concentrations were converted to concentrations with averaging periods comparable to the relevant MOECC AAQC. The AAQCs are developed to be protective of health and the environment. The 24-h NO_x concentration at the property line is 162 µg/m³, compared to the 24-h AAQC of 200 µg/m³. The annual SO₂ concentration at the property line is 22 µg/m³ compared to the annual AAQC of 55 µg/m³. The concentrations at the property line are well

below the AAQC, therefore NO_x and SO_x are not likely to have potential effects on ecological receptors located at the property line.

Hydrazine and morpholine are released to the air through atmospheric boiler emissions, as described in Section 3.1.2.1. The releases due to boiler venting were compared against acute toxicity benchmarks. The benchmarks considered were Lowest Observable Adverse Effect Levels (LOAELs) converted to NOAELs by applying a safety factor of 10. This conversion factor has been used to derive the Canadian Water Quality Guidelines for the Protection of Aquatic Life (CCME, 1999a), and is the most conservative factor cited in Suter *et al.* (1993).

The maximum ½-hour POI concentration for morpholine was 299.3 µg/m³, below the acute toxicity benchmark for morpholine of 780,000 µg/m³ (WHO, 1996) (Appendix A, Table A.14); therefore, morpholine was not carried forward for further assessment.

The ½-hour POI for hydrazine has been replaced in the ESDM with an annual average concentration based on MOECC request. The maximum annual average concentration for hydrazine of 6.9E-04 µg/m³ (Appendix A, Table A.14) is below the chronic toxicity benchmark for hydrazine of 6 µg/m³ (EC/HC, 2011). Maximum annual average concentrations for hydrazine were also converted to ½ hour concentrations using the MOE averaging equation for comparison against acute toxicity benchmarks. The maximum estimated ½ hour concentration for hydrazine of 0.011 µg/m³ did not exceed the acute toxicity benchmark of 10,600 µg/m³ for hydrazine (EC/HC, 2011). Therefore, hydrazine was not carried forward for further assessment.

Based on the screening presented in Appendix A, Table A.14 for chemicals released to air, maximum concentrations are below their respective screening levels; therefore, no air COPCs are carried forward for further assessment in the EcoRA.

There may be individual species located within the PN site boundary including potential species at risk that may be exposed to air COPCs; however, this pathway is expected to be minor, and there is not a robust assessment approach that can assess exposure via inhalation and evaluate toxicity to mammals and birds.

4.1.3.2 Chemical COPCs in Surface Water

4.1.3.2.1 Liquid Effluent

The surface water screening is based on measurements of COPCs discharged from 2011 to 2015 into the PN discharge channels, as well as lake water measurements collected in 2014 and 2015. The station effluent from the CCW discharge channel is discussed in Section 3.1.2.2 and the screening based on effluent discharge is presented in Table A.8. Based on the maximum concentrations of contaminants observed in station effluent from 2011 to 2015, hydrazine, morpholine, and total residual chlorine exceeded screening levels and are therefore carried forward for further quantitative assessment.

4.1.3.2.2 Lake Water

The 2014 ERA (EcoMetrix, 2014) evaluated lake water data from 2006 and carried forward hydrazine, morpholine, total residual chlorine, copper, and cadmium in the quantitative analysis in the EcoRA. As discussed in the COPC screening for the HHRA (Section 3.1.2.2), a surface water monitoring program was conducted in the summer of 2015 as part of the updated baseline environmental program, to quantify the concentration of COPCs in the PN discharge channels. For the current assessment, the 2015 surface water quality data (Appendix A, Table A.9), were screened against the lowest of PWQO or CCME water quality guidelines (or guidelines from other jurisdictions such as British Columbia MOE where Ontario or CCME values were not available), as well as mean background values collected from Cobourg (LWC-1), where no guideline existed. These background values are in general agreement with the 95th percentile of Lake Ontario background values from the Drinking Water Surveillance Program (DWSP) (MOECC, 2013a) previously used in the Pickering ERA (EcoMetrix, 2014). Concentrations of parameters in lake water samples that exceeded background by less than 20% were not identified as exceedances. Differences of less than 20% are typically not statistically discernible or measurable in the field or laboratory (Suter *et al.*, 1995; Suter, 1996). Toxicity benchmarks were also used if environmental quality guidelines were lacking, and background concentrations were exceeded by more than 20%.

As recommended by Clause 7.2.5.3.2 in CSA N288.6-12, screening criteria should represent no-effect levels. Toxicity benchmarks were generally obtained from Suter and Tsao (1996), modified from Borgmann *et al.* (2005), and modified from EC/HC (2011). These benchmarks represented secondary chronic values (SCV), modified LC₅₀ values (acute to chronic, and 50% to no-effect), and modified no-effect concentrations (acute to chronic), and are appropriate as screening levels.

The maximum measured concentration of copper and morpholine exceed their surface water quality screening levels. This is consistent with lake water samples from 2006 where elevated levels of both copper and morpholine were observed. In 2006 copper was observed at 0.0025 mg/L at the end of the PN U5-8 discharge channel where the channel enters the lake. The location of LWE-1 from the 2015 sampling campaign is not far from a stormwater discharge pipe (M5-1), which could influence copper concentrations in the lake to a small extent.

For some COPCs without environmental water quality guidelines (alkalinity, barium, calcium, and potassium), the maximum measured PN lake water concentration marginally exceeded – between 3 and 15% – the mean Lake Ontario background concentration. Differences of less than 20% are typically not statistically discernible or measurable in the field or laboratory (Suter *et al.*, 1995; Suter, 1996). Since the measured concentrations differed from background by less than 20%, these metals are not carried forward for further quantitative assessment.

The maximum measured concentration of sodium (23 mg/L) exceeded background by more than 20%. Therefore, toxicity benchmarks were used to clarify risk. Suter and Tsao (1996) presents a lowest chronic value (LCV) of 680 mg/L for sodium. The LCV for sodium was converted to a NOEC by incorporating a safety factor of 10. As described in Section 4.1.3.1, a safety factor of 10 has been used to derive the Canadian Water Quality Guidelines for the Protection of Aquatic Life (CCME, 1999a), and is the most conservative factor cited in Suter *et al.* (1993). The maximum measured sodium concentration is less than the NOEC and is therefore not carried forward for further quantitative assessment.

Based on the 2014 EMP supplementary study (EcoMetrix, 2015) for hydrazine in lake surface water, the maximum observed hydrazine concentration (0.25 µg/L) around PN was below the screening level of 2.6 µg/L (EC, 2013). Environment Canada has developed a Federal Environmental Quality Guideline (FEQG) for hydrazine of 2.6 µg/L for fresh water (EC, 2013). This value represents a predicted no-effect concentration based on an acute toxicity threshold with a safety factor (EC/HC, 2011). Since the maximum observed hydrazine concentration (0.25 µg/L) in lake water was below the screening level of 2.6 µg/L; hydrazine is not carried forward for further quantitative assessment in the EcoRA

Overall, based on the screening conducted for lake water the following COPCs are carried forward for the EcoRA: morpholine and copper.

4.1.3.2.3 Surface Water and Sediment at Frenchman's Bay

As part of the updated baseline environmental program, surface water and sediment data were collected in the summer of 2015 from Frenchman's Bay. Frenchman's Bay, a provincially significant wetland, is designated an Environmentally Sensitive Area by the TRCA, and is an Aquatic Biology Core Area. Frenchman's Bay is a habitat for wetland vegetation, mainly cattails, benthic invertebrates, fish, and wildlife. The wetland is located in the northern section of the bay. The 2014 ERA (EcoMetrix, 2014) assessed biota at the mouth of the bay where sediment data were collected, and where waterborne emissions from PN have the greatest impact – this is a conservative assumption. One of the main objectives of the Frenchman's Bay surface water and sediment sampling program was to address recommendations in the 2014 ERA to sample sediment and water in the northern section of Frenchman's Bay to reduce uncertainty in the ERA, and to provide additional data for the southern section of the bay.

Surface water and sediment samples were collected in July 2015 from two general areas in Frenchman's Bay, the north end and the south end. In each area of Frenchman's Bay, 10 sediment samples and 3 surface water samples were collected (see Table 4.4, Figure 4.2 and Figure 4.3). Water samples were analyzed for alkalinity, ammonia (total and un-ionized), biochemical oxygen demand, chemical oxygen demand, hardness, pH, conductivity, temperature, total suspended solids, total residual chlorine (in-situ), petroleum hydrocarbons (PHC F1 to F4), morpholine, metals, total organic carbon, and radionuclides. Sediment samples were analyzed for particle size, total organic carbon, metals, and

radionuclides. Results for radionuclides for surface water and sediment are discussed in Sections 4.1.3.6 and 4.1.3.7, respectively.

Table 4.4: Frenchman's Bay 2015 Sampling Locations and Descriptions

Location	Sample ID	UTM Easting	UTM Northing	Sample Depth (m)	Depth to Bottom (m)
North end of Frenchman's Bay	Location 1	653410	4853825	0.3 (water) 0-0.05 (sed)	0.59
	Location 2	653379	4853766	0.3 (water) 0-0.05 (sed)	1.2
	Location 3	653273	4853843	0.3 (water) 0-0.05 (sed)	1.6
	F-4	652982	4853934	0.35 (sed)	0.35
	FB-5	653128	4853686	0-0.05 (sed)	1.1
	FB-6	653273	4853649	0-0.05 (sed)	1.5
	FB-7	653381	4853637	0-0.05 (sed)	1.4
	FB-8	653490	4853646	0-0.05 (sed)	1.3
	FB-9	653342	4853903	0-0.05 (sed)	1.5
	FB-10	653138	4853839	0-0.05 (sed)	1
South end of Frenchman's Bay	PN-1-1	653866	4853078	0-0.05 (sed)	2.3
	PN-2-1	653748	4853189	0-0.05 (sed)	2.1
	PN-3-1	653799	4853037	0-0.05 (sed)	2.4
	PN-4-1	653642	4853073	0-0.05 (sed)	2.3
	PN-5-1	653600	4852957	1 (water) 0-0.05 (sed)	2
	PN-6-1	653918	4853230	0-0.05 (sed)	1.4
	PN-7-1	653981	4853078	0-0.05 (sed)	2.1
	PN-8-1	653829	4852992	0-0.05 (sed)	2
	PN-9-1	654051	4852958	1 (water) 0-0.05 (sed)	2.5
	PN-10-1	653927 (water) 653984 (sed)	4852961 (water) 4852938 (sed)	1 (water) 0-0.05 (sed)	1.9

Water Results

Frenchman's Bay water concentrations were screened against the lowest of PWQO or CCME water quality guidelines (or guidelines from other jurisdictions such as British Columbia MOE where PWQO or CCME values were not available). Where no guideline existed, mean background values from Cobourg (LWC-1 from lake surface water sampling program) were used as screening levels (there were not enough data points for 95th percentile evaluation). These background values are in general agreement with the 95th percentile of Lake Ontario background values from the DWSP (MOECC, 2013a) previously used in the 2014 ERA (EcoMetrix, 2014). Concentrations of parameters in lake water

samples that exceeded background by <20% were not identified as exceedances, as described in Section 3.1.2.2.2. Toxicity benchmarks were also used where environmental quality guidelines were lacking, and background concentrations were exceeded by more than 20%.

The maximum concentrations of copper, total aluminum, and iron at Frenchman's Bay exceeded their respective CCME water quality guidelines. However, dissolved aluminum concentrations were consistently below the PWQO for dissolved aluminum.

The field pH in one water sample collected from the south end of Frenchman's Bay PN-5-1 marginally exceeded (8.56 at 1 m depth) the upper end of the pH range (6.5-8.5).

For potassium, sodium, and strontium no water quality guidelines existed and background concentrations were exceeded by more than 20%; therefore, toxicity benchmarks (SCVs and LCVs) from Suter and Tsao (1996) were used. The SCV for strontium is considered a NOEC and is appropriate for screening. LCVs for potassium and sodium were converted to NOECs by incorporating a safety factor of 10. Water concentrations for strontium and potassium were below their respective toxicity benchmarks. The maximum sodium concentration observed at Frenchman's Bay exceeded its toxicity benchmark.

Based on the screening presented in Table A.10 (Appendix A), total aluminum, copper, iron, and sodium exceed water quality screening levels and are carried forward for further quantitative assessment in the EcoRA. The contribution from PN to water concentrations observed in Frenchman's Bay is discussed in the exposure assessment and in Appendix E.

Sediment Results

Concentrations of sediment samples collected from Frenchman's Bay were compared against the lowest of the CCME Interim Sediment Quality Guidelines (ISQGs) and the Ontario MOECC Lowest Effect Levels (LELs). For substances not included in CCME ISQGs or MOECC LELs, the LELs from Thompson *et al.* (2005) were used. If a COPC concentration in sediment is less than the LEL or ISQG, adverse effects on benthic invertebrate communities are not anticipated for that COPC. COPC concentrations in sediments that exceed the LEL or ISQG will not necessarily indicate that adverse effects are occurring but suggest that further investigation is warranted.

For substances without sediment quality guidelines, 95th percentiles of Regional Lake Ontario background sediment values from Lake Ontario background data were used for screening purposes (OPG, 2009). Concentrations of parameters in sediment samples that exceeded background by <20% were not identified as exceedances, as described in Section 3.1.2.2.2.

Based on the screening presented in Table A.11 (Appendix A), for surficial sediment samples collected in July 2015 from the north and south ends of Frenchman's Bay the following metals exceeded sediment quality screening levels: aluminum, bismuth, boron,

cadmium, calcium, chromium, copper, lead, manganese, nickel, phosphorus, thallium, tin, and zinc. Total organic carbon also exceeds the MOE LEL, and is therefore carried forward for further quantitative assessment. Exceedances were expected as Frenchman's Bay is greatly influenced by urban runoff. The sediment results are comparable with the TRCA (2009b) and the OPG (2002b) sediment results from Frenchman's Bay.

The contribution from PN to sediment concentrations observed in Frenchman's Bay is discussed in the exposure assessment and in Appendix E.



Figure 4.2: North Frenchman's Bay 2015 Sampling Locations

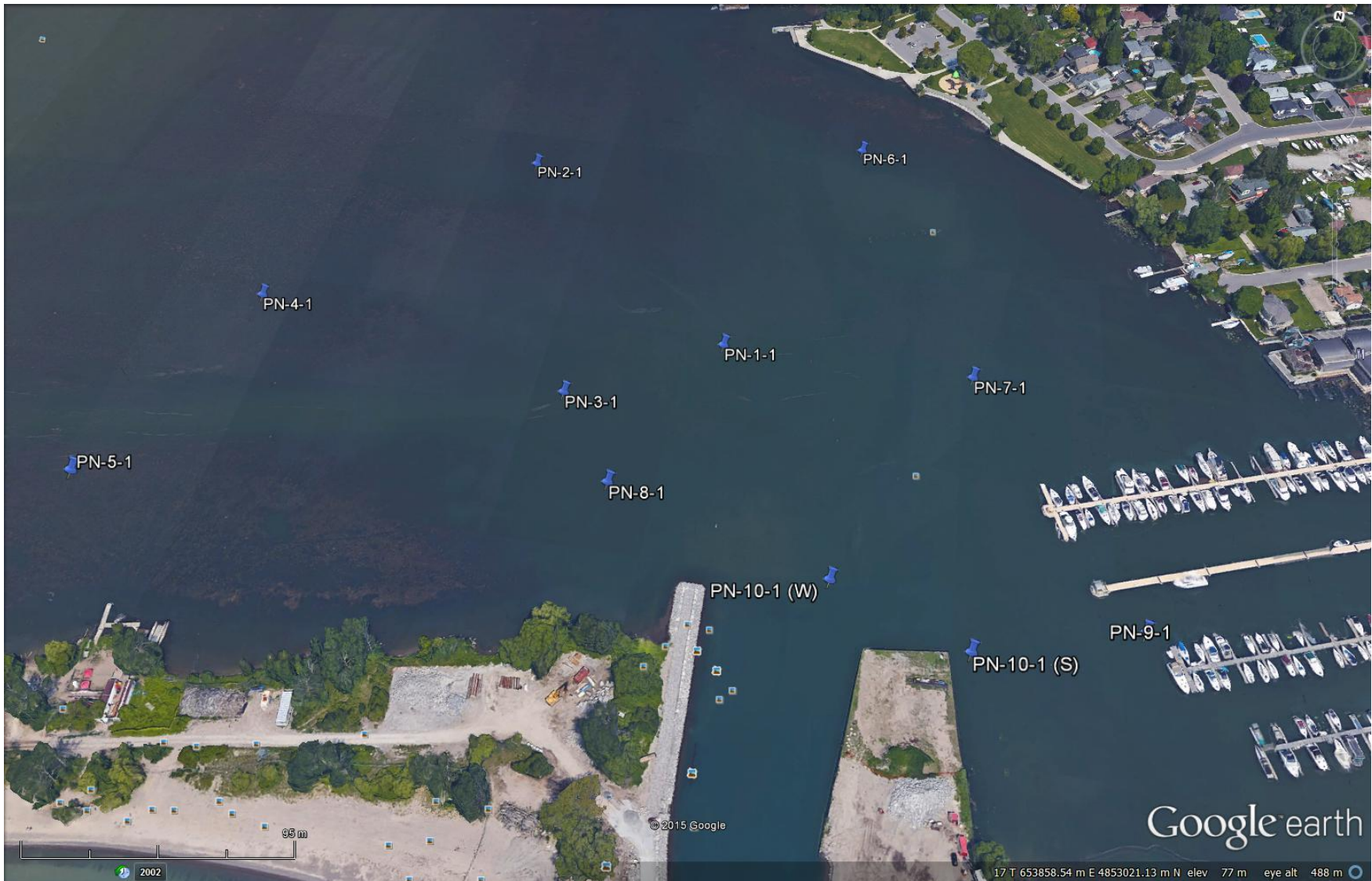

Figure 4.3: South Frenchman's Bay 2015 Sampling Locations

4.1.3.2.4 Stormwater

Stormwater runoff from the PN site is collected by the stormwater drainage system and directed through drainage pathways south to Lake Ontario. Surface drainage around PN is comprised of 19 catchments, as discussed in Section 3.1.2.2.3. The point of discharge concentrations were compared against the water quality guidelines (PWQO, CCME, Lake Ontario Background) protective of ecological endpoints, and none of the measured contaminants exceeded the selected screening levels (see Appendix A, Tables A.4 to Table A.7). Therefore, stormwater is not discussed further in this ERA.

4.1.3.2.5 East Landfill Surface Water

Bi-annual surface water sampling was conducted at the East Landfill every two years from 1996 to 2013 as part of PN's East Landfill Perpetual Care Program. The program involved a visual inspection, surface water and groundwater sampling from a number of locations including seepage and ditch points as shown on Figure 4.4. All results were reported to the MOECC. The analytical parameters monitored in this surface water program included: alkalinity, biochemical oxygen demand (5-day), calcium, copper, dissolved organic carbon, hardness, pH, phenols, sulphate, total suspended solids, total phosphorous and zinc. For some years a wider list of metals including mercury was included in the program. As of 2013, OPG has completed its commitment to monitoring surface water at the East Landfill as part of its Perpetual Care Program.

For the purpose of this EcoRA 2010 and 2012 sample concentrations were compared against the lowest of the PWQO or CCME water quality guidelines, where available (Table A.12). Where no PWQO or CCME guideline was available data were obtained from other jurisdictions such as British Columbia MOE or from MacDonald (1999). For the assessment of east landfill surface water only, parameters without guidelines have not been carried forward given that these are substances of minimal concern with presumably small flows to the lake.

Ditch 4 and Ditch 6 are the final surface water discharge points from the east landfill into Lake Ontario, with the majority of the effluent coming from Ditch 6. Ditches 1, 2A, 3, and 5 are located upgradient of the discharge points for Ditch 4 and Ditch 6. In 2010 and 2012, Ditch 4 was not sampled, due to lack of water, accessibility, and safety concerns.

Trigger levels developed by OPG, in consultation with the MOECC have been established for copper (0.15 mg/L) and zinc (0.9 mg/L) at the sampling locations for Ditch 4 and Ditch 6 (OPG, 2011f). These levels are 30 times the PWQO. Data from 2010 and 2012 indicate no exceedances of trigger levels and no exceedances of water quality guidelines for copper and zinc, as shown in Table A.12.

Based on data from Ditch 6 from 2010 to 2012, the COPCs that exceed screening levels are phosphorous and sulphate. Although observed phosphorus concentrations in Ditch 6 in 2010 and 2012 exceed the provincial guideline for nuisance algal growth, phosphorus in its

chemically combined forms is not toxic to aquatic life (MOEE, 1979). These combined forms, such as phosphate, are the expected forms on the site, and in most surface waters. Both MOECC (MOEE, 1994) and CCME (1999a) water quality guidelines for total phosphorus focus on its potential effects in enhancing algal growth. The implications of exceeding the phosphorus guideline in Ditch 6 are possible enhancement of algal growth and associated aquatic community effects, which are not uncommon in drainage ditches.

No PWQO or CCME water quality guideline was available for sulphate. Based on sulphate concentration in the ditches exceeding the BC MOE water quality guideline, sulphate has been carried forward for further assessment in the EcoRA, in order to confirm the conclusion that the East Landfill does not pose a potential concern to the environment.

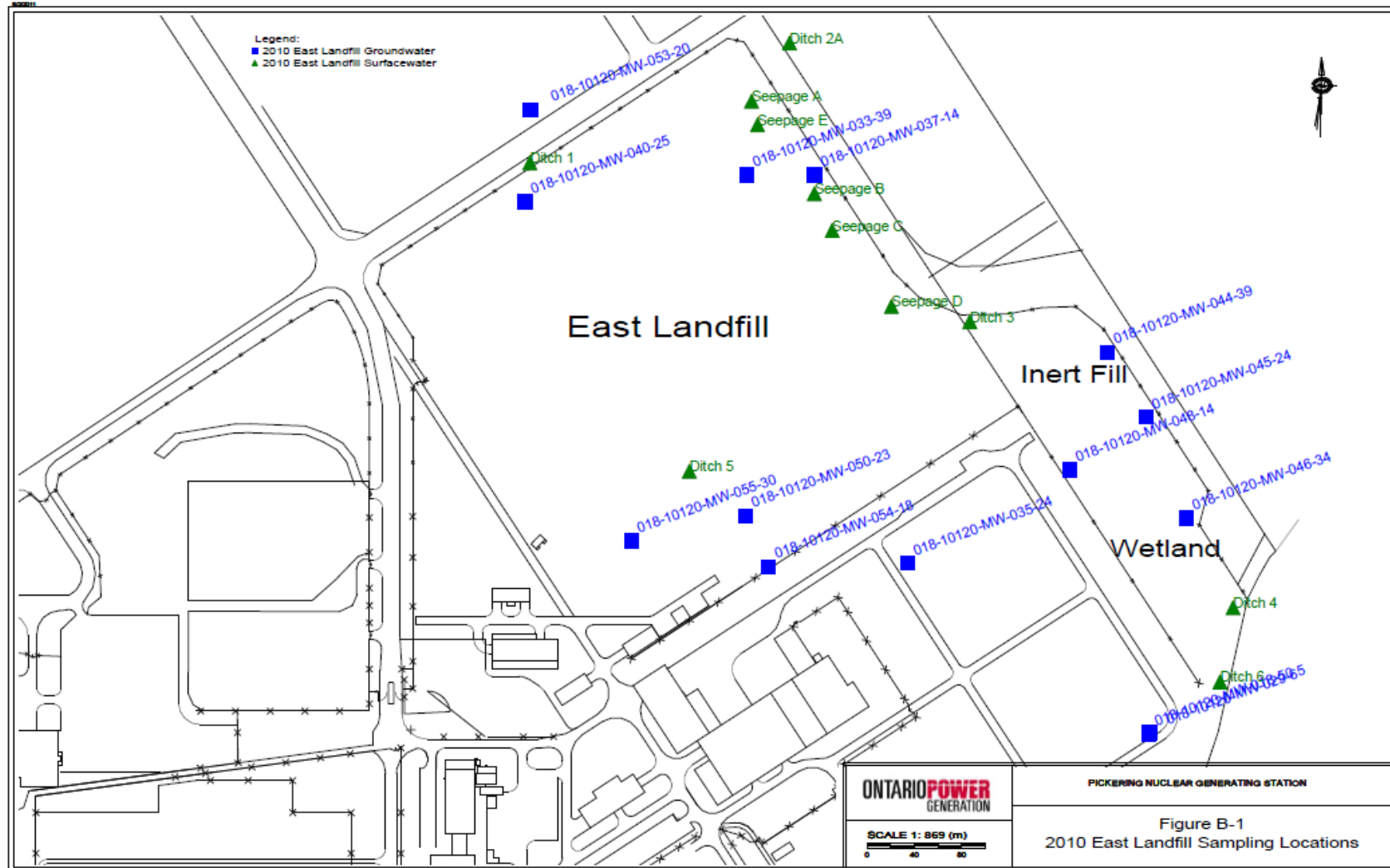

Figure 4.4: Surface Water Sampling Points for the East Landfill Perpetual Care Program (OPG, 2011f)

4.1.3.3 Chemical COPCs in Soil

A site-wide soil monitoring program to characterize soil quality at the PN site was conducted in 1999 by CH2M Gore & Storrie Ltd. and was summarized in the Geology Hydrogeology and Seismicity TSD (Golder, 2007d). Since the original 1999 soil characterization study was completed, the MOECC has updated O.Reg 153/04 and issued new soil quality standards (MOE, 2011). In the 2014 ERA (EcoMetrix, 2014), soil samples from the site-wide soil monitoring program taken from a depth of 0 to 1.5 m (approximately 5 feet) were compared against updated screening criteria. This depth is appropriate for the terrestrial receptors assessed in the EcoRA. Based on the screening conducted, the 2014 ERA carried arsenic, cadmium, copper, lead, strontium, thallium, and zinc forward for further quantitative analysis in the EcoRA. Based on the results of the 2014 ERA further investigation of metals in soil was recommended in areas where benchmarks for soil invertebrates and plants were exceeded, based on 1999-2000 soil data. Areas on the PN site that were recommended in the 2014 ERA for further investigation included:

- the eastern portion of the PN site;
- north of the intake channel, just south of the Old Water Treatment Plant;
- south west of the East Landfill;
- Parking Area A at Montgomery Road; and
- the area near PN U1 and U2.

A site inspection was performed on May 20, 2015 to assess habitat on the PN site, specifically in the areas listed above, to inform the baseline sampling program. Based on the site inspection, areas without vegetation or organic soil cover were removed from the soil program. These areas were removed as they do not provide a suitable habitat for receptors. Based on the assessment of potential habitat, the area north of the intake channel and the area near PN U1 and U2 were removed from the soil monitoring program conducted in October 2015.

The final eight soil sampling locations are identified in Table 4.5 and Figure 4.5 and focus on areas of known soil impact identified in previous ERAs, environmental site assessments (ESAs), and a site inspection on May 20, 2015. Surface soil samples were collected and analyzed for polycyclic aromatic hydrocarbons, volatile organic compounds, petroleum hydrocarbons F1 to F4, metals and inorganics, glycol, tritium, gamma emitters (i.e., cesium-137, cesium-134, cobalt-60) and carbon-14.

The focus on surface soils (0 to 20 cm) is appropriate for assessment of baseline ecological risk. In general valued ecosystem components ingesting soils would only access shallow/surface soils; a shallow root zone is appropriate for herbaceous plants, and soil

invertebrates are primarily active in the shallow humus layer. The depth of 0.2 m is considered conservative given that most sources of impact are at surface.

Table 4.5: 2015 Soil Sampling Locations and Descriptions

Location ID	Location Description	UTM Easting	UTM Northing
GMS-26	West of Parking Lot E	655704	4853082
GMS-28	Eastern portion of the site	656019	4852552
GMS-31	Eastern portion of the site	656290	4852486
GMS-38	Parking Area A at Montgomery Rd	655445	4852996
Site 7 SS4	East Site Carpenter Shop	656073	4852560
Site 14 SS3	East Site – ditch north of the east site warehouse	656256	4852860
Site 14 SS5	East Site – ditch north of the east site warehouse	656124	4852875
Site 14 SS6	East Site – pipe fabrication shop drainage ditch	656134	4852853

The most stringent industrial value between the MOE (2011) standard (Table 3 standards for soil samples obtained greater than 30 m from a waterbody) and the CCME soil quality guideline was selected as the screening criteria, for comparison against the maximum soil concentration. A number of field investigations and grain size analyses conducted during Phase II Environmental Site Assessments at various locations on the PN site (CH2M Hill, 2005a-c, 2006), classified the soil texture at Pickering as coarse. The screening table is shown in Appendix A in Table A.13.

The maximum soil concentration for petroleum hydrocarbon F4 (at Site 14-SS5) exceeds the MOE (2011) Table 3 standard. Petroleum hydrocarbons in soil were assessed in an ESA for the same locations at Site 14 (drainage ditches) (CH2M Hill, 2007). The ESA showed an exceedance of the Table 3 standard for F3 at location Site 14-SS6, but petroleum hydrocarbons were below standards for all other locations at Site 14. The increase in petroleum hydrocarbon F4 might be related to minor historical spills and impacted surface water runoff discharging into the ditches.

Although no screening levels exist for total glycols, total glycols have not been carried forward for further quantitative assessment. All soil concentrations for diethylene glycol, ethylene glycol, and propylene glycol are below their respective screening levels and detection limits.

Cadmium, strontium, and thallium were assessed in the 2014 ERA, but did not exceed screening levels based on 2015 site soil data. The 2014 ERA concluded that the maximum cadmium concentration marginally exceeded the terrestrial plant benchmark south west of the East Landfill. Limited toxicity data were available for thallium and strontium. Where

toxicity benchmarks were available, strontium soil concentrations were below these benchmarks. Although thallium concentrations did exceed toxicity benchmarks, the 2014 ERA, concluded that based on the limited extent of the elevated thallium concentrations in soil (eastern portion of the PN site, and south west of the East Landfill), detrimental effects on terrestrial plant communities at the PN site are not expected. Based on the updated 2015 site soil data from comparable locations, cadmium, strontium and thallium are not carried forward in the EcoRA.

Based on the screening presented in Table A.13 (Appendix A), for surficial soil samples collected in October 2015 from eight locations around the PN site, the following soil COPCs are carried forward for further quantitative assessment in the EcoRA: arsenic, copper, lead, zinc, petroleum hydrocarbon F4, and cyanide. Exceedances of soil screening levels are generally limited to soil samples collected from the eastern portion of the PN site (Site 14 and GMS-28).

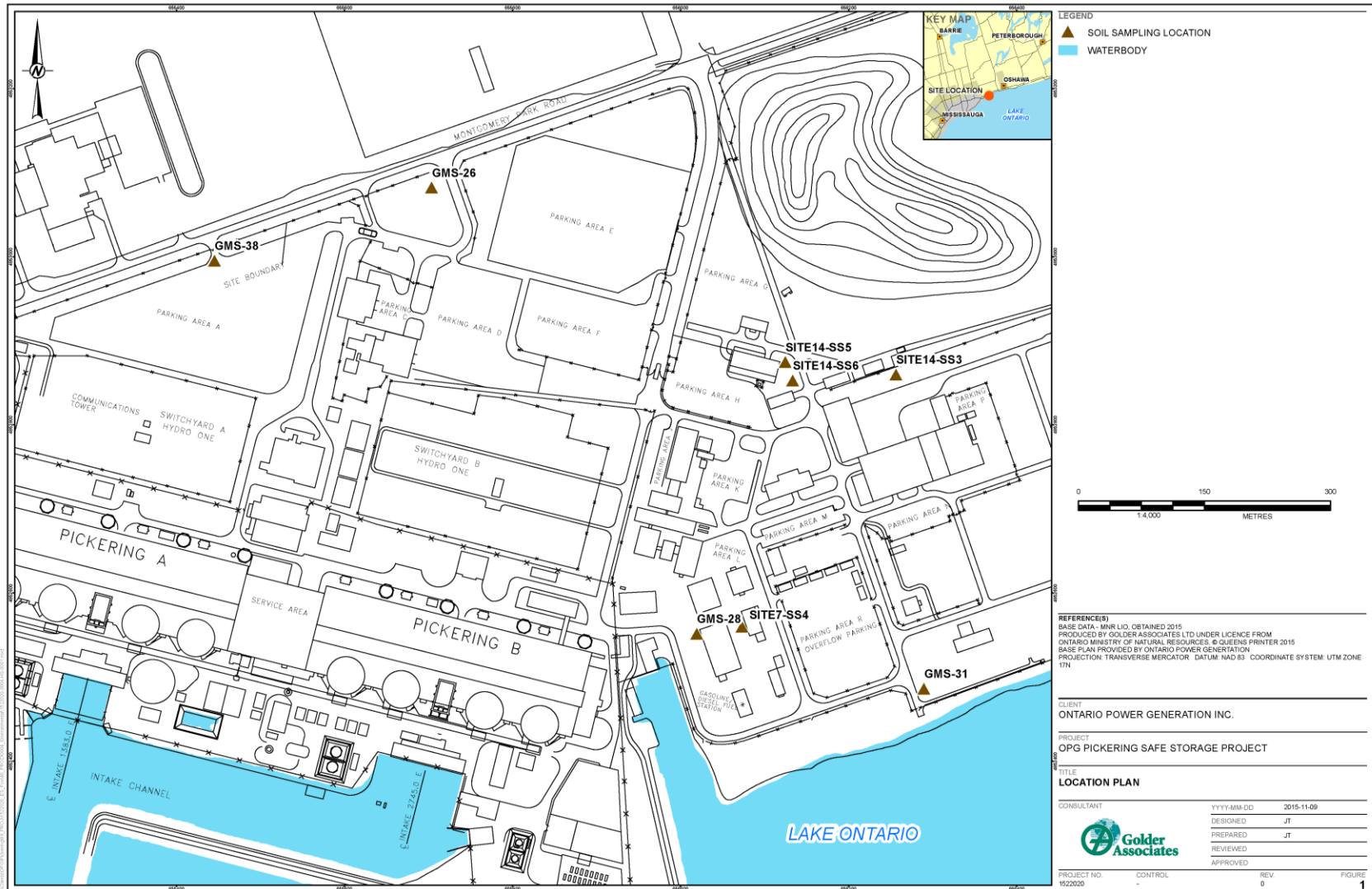

Figure 4.5: 2015 Soil Sampling Locations on Pickering Nuclear Site

4.1.3.3.1 Applicability of Table 1 Site Condition Standards

The use of O.Reg. 153/04 Table 1 Full Depth Background Site Condition Standards (Table 1 Standards) was considered for applicability to screening of COPCs in soil at the PN site. Although O.Reg. 153/04 does not strictly apply to the Site, as a Record of Site Condition is not being obtained, the use of O.Reg. 153/04 standards (as noted in *Soil Ground Water and Sediment Standards for Use Under Part XV.1 of the Environmental Protection Act*, MOECC, April 15, 2011) was considered as a basis for screening soils in the Risk Assessment.

According to O.Reg. 153/04, Table 1 Standards are required for an area of natural significance or land within 30 m of an area of natural significance, if soil pH is non-neutral (i.e. less than 5 or greater than 9 for surface soils) or for other cases as deemed appropriate by a qualified person. Soil pH from the 2015 data ranged from 7.35 to 8.07. The potential for the Site to be part of, or within 30 m from, an area of natural significance was assessed. Based on O.Reg. 153/04 only “an area which is habitat of a species that is classified under section 7 of the Endangered Species Act, 2007 as a threatened or endangered species” would potentially qualify at the PN site for classification as an area of natural significance. As discussed below for the threatened or endangered species recorded on-site, there is no potential for soil contamination in such areas. To evaluate potential habitat for threatened and endangered species, the recorded presence of threatened or endangered species in areas of potential soil impact related to OPG activities was evaluated. The TRCA and OPG have prepared a number of documents on terrestrial monitoring in the vicinity of the PN site (TRCA, 2009a; 2013; 2015, OPG, 2015c).

A review of all terrestrial flora and fauna identified on the PN site during 2011 to 2015 was performed against the provincial *Endangered Species Act*, 2007 for threatened or endangered species. The following threatened and endangered species have been identified within the PN site:

- Barn Swallow (*Hirundo rustica*) – threatened provincially
- Butternut (*Juglans cinerea*) – endangered provincially

Butternut was identified in TRCA (2009a) as being located in the Fresh-Moist Sugar Maple – Hemlock Mixed Forest environmental land classification (ELC). According to TRCA (2014), Fresh-Moist Sugar Maple – Hemlock Mixed Forest would match the vegetation type at Kinsmen Woodlot, which is outside of the PN site study area, shown on Figure 4.1) (i.e. there are no potentially contaminating activities associated with the Kinsmen Woodlot).

The TRCA has not performed terrestrial monitoring on other portions within the operational area of the Pickering site; however the lack of vegetation and organic soil cover, would indicate this is not a suitable habitat for threatened or endangered species.

The one exception is birds such as the Barn Swallow which may be present on-site. These birds however consume flying insects and do not consume soil invertebrates. Flying

insects have limited (if any) exposure to soil and are considered a negligible pathway as compared to the generally accepted ingestion of soil and soil invertebrates considered in the ERA.

Several of the buildings on-site may provide a suitable habitat for the Barn Swallow; however, these are not ground based locations and not considered a concern for direct soil contact of these receptors. As such, use of the MOECC Table 1 Standards was not considered warranted.

4.1.3.4 Chemical COPCs in Groundwater

As discussed in Section 3.1.2.4, the 2012 PN Groundwater Monitoring Program Design (EcoMetrix, 2012) identified COPCs that should be the focus of OPG's groundwater monitoring program. Based on the screening assessment of past measurements, polycyclic aromatic hydrocarbons, petroleum hydrocarbons, BTEX compounds, and inorganics (chloride, iron and sodium) were recommended as the focus of the groundwater monitoring program at specific locations. Results from groundwater monitoring conducted from 2012 to 2015 (OPG, 2016d; 2015b) are consistent with the previous assessment (EcoMetrix, 2012).

Although COPCs have been identified through the screening assessment in EcoMetrix (2012), the lack of ecological exposure pathways for site groundwater indicates that there is no need for inclusion of these pathways in the EcoRA. The ecological receptors that are most likely to be exposed to COPCs migrating with groundwater are those that reside in zones of groundwater discharge in Lake Ontario. These receptors include benthic invertebrates living in or on shoreline sediments, and possibly shoreline vegetation with roots near the water table that may be exposed to groundwater when the water table is high. Most on-site ecological receptors are not likely exposed to groundwater, since the depth to groundwater on-site is at least 2 metres (Golder, 2007d).

In addition, due to the direction of groundwater flow at the site, there is no exposure pathway between offsite terrestrial biota and groundwater exposed to activities due to the operation of PN. Groundwater at the site flows towards Lake Ontario, and the effects on aquatic biota are assessed there. As such, no groundwater COPCs are carried forward for further quantitative assessment in the EcoRA

4.1.3.5 Radiological COPCs in Air

External exposures through the air immersion and inhalation pathways are considered to be minor compared to the ingestion pathway, and were ignored for radionuclides, with the exception of noble gases (CSA, 2012). Therefore, the screening for radionuclides in the air pathway focuses on noble gases only.

Ar-41 is the predominant radionuclide measured in noble gas around the Pickering site. The number of operating days of PN U1-4 is related to emissions of Ar-41. Since 2003, an

increasing trend of Ar-41 emissions has been observed, and is the result of PN U4 returning to service, and PN U1 returning to service in 2005. In 2011, repairs were performed to reduce air ingress via PN U4 calandria vault dryers, reducing Ar-41 levels at the site boundary, compared to 2010 (OPG, 2012c). Ar-41 emissions have been evaluated for human receptors through the annual EMP reports. The dose to non-human biota from exposure to noble gases (predominantly Ar-41) is presented in the exposure assessment.

4.1.3.5.1 Pickering Waste Management Facility

As discussed in Section 3.1.2.5.1, the gamma fields outside the DSC storage buildings at the PVMF are due primarily to contributions from direct gamma radiation and secondarily from gamma skyshine. The neutron dose rate is negligible compared to gamma dose rates. As shown in Table 3.4, the maximum dose rate from the PVMF at full capacity could range from 6E-06 to 1.1E-03 $\mu\text{Sv/h}$ at the PN property boundary locations. Assuming that this is a whole body effective dose, the tissue absorbed dose at body surface may be slightly higher, but the whole body tissue absorbed dose for wildlife may be lower. It is difficult to translate the human effective dose to a whole body absorbed dose for various wildlife species with different geometries; however, it has been assumed that the whole body effective dose for humans ($\mu\text{Sv/h}$) is equivalent to the whole body absorbed dose for wildlife ($\mu\text{Gy/h}$). For the EcoRA, it has been assumed that the dose to any ecological VEC within the vicinity of the PVMF (at the closest PN property boundary) could range from 6E-06 to 1.1E-03 $\mu\text{Gy/h}$, well below the terrestrial dose benchmark of 100 $\mu\text{Gy/h}$.

For ecological receptors residing on the PN site, in the immediate vicinity of the PVMF, the expected dose rates are shown in Table 4.6. Assuming the wildlife whole body absorbed dose is comparable to the human effective dose, the dose rate could be up to 0.5 $\mu\text{Gy/h}$ for ecological receptors in close proximity to the PVMF, assuming the PVMF is at full capacity.

The combined dose from the PVMF and other activities at PN to ecological receptors is discussed in the exposure assessment.

Table 4.6: Maximum Dose Rates in Close Proximity to PVMF Phase I and Phase II

Site	Location	Dose Rate ($\mu\text{Gy/h}$) at full capacity (OPG, 2013a)
PVMF Phase I	5 m from any wall ¹	0.5
PVMF Phase II	15 m from north wall ²	0.25
	15 m from south wall ²	0.18
	15 m from west wall ²	0.15
	15 m from east wall ²	0.15

Notes:

1. PN station security fence
2. PVMF Phase II perimeter fence

4.1.3.6 Radiological COPCs in Surface Water

The Radiation and Radioactivity TSD (SENES, 2007c) identified a number of radionuclides released to water that should be carried forward for the dose assessment. The 2011 DRL Report for PN (OPG, 2011a, b) presents the same effluent release groups for water, with the exception of including gross alpha.

The DRLs for the effluent release groups were calculated based on the selection of the radionuclide with the most restrictive DRL, according to the process outlined in the COG DRL Guidance document (Hart, 2008). Radionuclides were selected based on the following criteria for inclusion:

- Radionuclides are regularly present in the effluent; and
- Radionuclides represent no less than 1% of the total radioactivity present.

Based on these criteria, DRLs were calculated for tritium oxide (HTO), carbon-14, and gross beta/gamma (phosphorous-32, sulphur-35, scandium-46, chromium-51, manganese-54, iron-55, iron-59, cobalt-60, strontium-90 (yttrium-90), zirconium-95, niobium-95, ruthenium-106, tin-113, antimony-124, antimony-125, iodine-131, cesium-137, europium-154, gadolinium-153, terbium-160, zinc-65). The radionuclides considered for use in DRL calculations were also considered for possible assessment in the EcoRA. The limiting radionuclides (i.e., the radionuclide with the highest dose per unit release) for gross beta/gamma in water were used to represent all radionuclides in each grouping. Different from the HHRA, cobalt-60 was chosen to represent gross beta/gamma emissions in water, since cobalt-60 is the limiting radionuclide among beta/gamma emitters for aquatic biota, and therefore provides a conservative estimation of radiological dose (see Appendix C). Cesium-134 was not considered for use in the DRL calculations since it occurred at <1% of the total activity. These radionuclides are generally consistent with those measured in surface water during the 2015 updated baseline environmental program, including tritium, carbon-14, cesium-134, cesium-137, and cobalt-60.

Gross alpha radionuclides do not need to be carried forward for the risk assessment. The level of airborne and waterborne gross alpha emissions from OPG nuclear facilities has been considered to be negligible (OPG, 2005b). This position is supported by determination of alpha activity in the heat transport water and estimates of the maximum probable emission levels under normal and abnormal operating conditions. The airborne exhaust systems at PN contain HEPA filters which continuously filter particulate from the airborne effluents, thus capturing the alpha emitting particles, resulting in negligible emissions. A study on monthly gross alpha waterborne emissions was performed to establish an appropriate monitoring methodology (OPG, 2006b). Based on 2015 monitoring data, gross alpha waterborne concentrations at PN RLWMS are at MDL and their emissions are at a very small fraction (0.00002%) of the monthly DRL.

4.1.3.7 Radiological COPCs in Sediment

As discussed in Section 4.1.3.2.3, sediment data were collected in the summer of 2015 from Frenchman's Bay as part of the updated baseline environmental program. The radionuclides of interest were carbon-14, cobalt-60, cesium-134, and cesium-137. Frenchman's Bay is the closest location to PN that is considered a depositional area.

For two radionuclides (cobalt-60, cesium-134), the majority of sediment samples had concentrations of radionuclides below the detection limits. Cesium-137 and carbon-14 were generally detected and results are comparable with the COG sediment study results (Hart and Petersen, 2013).

4.1.3.8 Radiological COPCs in Stormwater

Stormwater was measured in 2015 and 2016 for radionuclides, as summarized in Tables A.4 to Table A.7 in Appendix A. Stormwater is directed to the PN U1-4 or PN U5-8 discharge channels, or to the lake, where it is rapidly diluted, resulting in low concentrations of radionuclides based on contribution from stormwater. Radionuclides are assessed in the exposure assessment based on lake water concentrations and effluent concentrations released from the station.

4.1.3.9 Radiological COPCs in Soil

The Radiation and Radioactivity TSD (SENES, 2007c) identified cesium-134, cesium-137, cobalt-60, and potassium-40 as relevant COPCs for soil and sediment. However, potassium-40 is environmentally abundant and not associated with station operations. The cesium and cobalt isotopes are included as COPCs in order to address potential concern about deposition of particulate activity. Only cesium-134 and cobalt-60 are specific to reactor operations, and these are typically not detected in EMP monitoring of either soil or sediment around the facility.

As discussed in Section 4.1.3.3, a soil monitoring program was conducted in October 2015 as part of the updated baseline environmental monitoring program, and to address recommendations in the 2014 ERA. With respect to radionuclides in soil, the 2014 ERA recommended further investigation of high tritium in soil concentrations near the reactor buildings to clarify the source and extent of these impacts, considering the calculated risks to soil invertebrates and avian consumers, based on 1999-2000 soil data. The ERA noted that avian consumers are unlikely to experience the highest concentrations observed, because of their wide foraging areas.

An inspection of the PN site was performed on May 20, 2015 to assess habitat in areas of potential sampling including areas within the protected area such as adjacent to the reactor buildings. Based on the inspection, areas without vegetation or organic soil cover were removed from the sampling plan as they do not provide a suitable habitat for receptors.

Based on the assessment of potential habitat, the area near PN U1 and U2 was removed from the soil monitoring program conducted in October 2015.

Soil samples were collected from eight locations around the PN site (Figure 4.5), and analyzed for tritium, gamma emitters (i.e., cesium-137, cesium-134, cobalt-60), and carbon-14.

4.1.3.10 Radiological COPCs in Groundwater

As discussed in Section 3.1.2.7, the 2012 PN Groundwater Monitoring Program Design (EcoMetrix, 2012) identified COPCs that should be the focus of OPG's groundwater monitoring program. Based on the screening assessment, tritium was recommended for inclusion in the groundwater monitoring program at specific locations. Results from groundwater monitoring conducted from 2012 to 2015 (OPG, 2016d; 2015b) are consistent with the previous assessment (EcoMetrix, 2012).

Although COPCs have been identified through the screening assessment in EcoMetrix (2012), the lack of ecological exposure pathways for site groundwater indicates that there is no need for inclusion of these pathways in the EcoRA. The ecological receptors that are most likely to be exposed to COPCs migrating with groundwater are those that reside in zones of groundwater discharge in Lake Ontario. These receptors include benthic invertebrates living in or on shoreline sediments, and possibly shoreline vegetation with roots near the water table that may be exposed to groundwater when the water table is high. Most on-site ecological receptors are not likely exposed to groundwater, since the depth to groundwater on-site is at least 2 metres (Golder, 2007d).

The risks to ecological receptors in the groundwater discharge zone are primarily from tritium, and are considered to be low as long as levels in the groundwater at the point of discharge on the shoreline remain below $3\text{E}+06$ Bq/L. This level of $3\text{E}+06$ Bq/L is very conservative, and assumes a terrestrial organism (earthworm) residing in groundwater; however, it would be protective of all aquatic biota (OPG, 2000b). Based on groundwater data from 2008 to 2012 the only locations where tritium in groundwater exceeds $3\text{E}+06$ Bq/L are around Unit 1 and one well near PN U5-8. Groundwater in the Unit 1 area migrates towards either the IFB A or Vacuum Building Ramp Sump and foundation drains. Groundwater from PN U5-8 flows to the Turbine Auxiliary Bay foundation drains, which is a hydraulic sink (EcoMetrix, 2012). Groundwater originating from these sources is monitored and not discharged directly to Lake Ontario. Additionally, relevant ecological receptors are located in the nearshore zones of Lake Ontario in the groundwater discharge area and are not found on-site.

In addition, due to the direction of groundwater flow at the site, there is no exposure pathway between offsite terrestrial biota and groundwater exposed to activities due to the operation of PN. Groundwater at the site flows towards Lake Ontario, and the effects on

aquatic biota are assessed there. As such, no groundwater COPCs are carried forward for further quantitative assessment in the EcoRA.

4.1.3.11 Physical Stressors

4.1.3.11.1 Noise

Noise levels due to PN may potentially cause disturbance to wildlife. The Pickering B EA Terrestrial Environment TSD (Golder, 2007c) concluded that, although some wildlife may be forced to leave their habitat due to noise levels, most wildlife in the area are likely accustomed to noise levels associated with an urban environment.

As part of the updated baseline environmental program, a noise monitoring program was carried out to monitor existing noise levels, as discussed in Section 3.1.2.8. The noise monitoring program included collecting existing noise levels for environmental noise for human and ecological receptors. The environmental noise results for human receptors are presented in Section 3.1.2.8.

Noise monitoring locations for Environmental Noise (ecological receptors) locations are shown on Figure 4.6 and Table 4.7. The long-term unattended and short-term attended noise monitoring locations for the Environmental Noise (ecological receptors) locations, ES-1 to ES-3, and AES-1 to AES-3 were selected using professional judgement in identifying potential wildlife habitats.

Table 4.7: Noise Monitoring Locations and Descriptions

Sampling ID	Description	Receptor Type	Noise Monitoring Duration
ES-1	Parkland	Ecological	Long-term
ES-2	Shoreline (West of PN)	Ecological	Long-term
ES-3	Open Area	Ecological	Long-term
AES-1	Open Area	Ecological	Short-term
AES-2	Open Area	Ecological	Short-term
AES-3	Shoreline (East of PN)	Ecological	Short-term

Environmental noise levels for ecological receptors were assessed for a sensitive time period – 06:00 to 10:00. There are no specific noise level thresholds for ecological receptors within regulatory documents. For the Environmental Noise (ecological receptors) locations, the long-term unattended noise monitoring was carried out between September 18 and September 25, 2015. Approximately 160 hours of data were collected at each noise monitoring location, with 115 hours considered to be valid data. Periods of inclement weather, unsuitable for noise measurements, were identified and excluded from the

calculations. Short-term attended measurements were carried-out to supplement the unattended monitoring data.

Un-weighted linear noise levels (dBZ) may be considered more appropriate for evaluating potential effects on ecological receptors than A-weighted (dBA) levels, which are used to describe human responses to noise. The un-weighted noise levels (L_{Zeq}) represent the actual acoustic energy in the atmosphere between 20 and 20,000 Hz, and can be considered a less biased representation of how ecological receptors may react to noise levels in the environment. However, as various literature references both un-weighted linear and A-weighted sound levels, both were collected during the noise monitoring program for ecological receptors. The results for noise levels collected during the baseline noise monitoring program at long-term unattended monitoring locations are shown in Table 4.8 to Table 4.10. The results for short-term attended monitoring locations are shown in Table 4.11.

Table 4.8: Environmental Noise (ecological receptors) Location ES-1 Long-term Unattended Noise Monitoring Results

Time Period	L_{Zeq} (1-h)			L_{Aeq} (1-h)		
	Average (dBZ)	Maximum (dBZ)	Minimum (dBZ)	Average (dBA)	Maximum (dBA)	Minimum (dBA)
Ecological (06:00 – 10:00)	64	66	60	50	53	44
Daytime (07:00 – 19:00)	65	69	60	49	54	44
Evening (19:00 – 23:00)	63	65	61	47	51	42
Night-time (23:00 – 07:00)	66	77	59	46	49	40
24 h	65	77	59	48	54	40

Table 4.9: Environmental Noise (ecological receptors) Location ES-2 Long-term Unattended Noise Monitoring Results

Time Period	L_{Zeq} (1-h)			L_{Aeq} (1-h)		
	Average (dBZ)	Maximum (dBZ)	Minimum (dBZ)	Average (dBA)	Maximum (dBA)	Minimum (dBA)
Ecological (06:00 – 10:00)	65	68	62	57	62	47
Daytime (07:00 – 19:00)	71	79	63	58	67	48
Evening (19:00 – 23:00)	66	73	63	56	62	47
Night-time (23:00 – 07:00)	65	68	62	57	62	47
24 h	69	79	62	57	67	47

Table 4.10: Environmental Noise (ecological receptors) Location ES-3 Long-term Unattended Noise Monitoring Results

Time Period	L_{Zeq} (1-h)			L_{Aeq} (1-h)		
	Average (dBZ)	Maximum (dBZ)	Minimum (dBZ)	Average (dBA)	Maximum (dBA)	Minimum (dBA)
Ecological (06:00 – 10:00)	63	68	60	47	54	43

Time Period	L _{Ze} q (1-h)			L _A eq (1-h)		
	Average (dBZ)	Maximum (dBZ)	Minimum (dBZ)	Average (dBA)	Maximum (dBA)	Minimum (dBA)
Daytime (07:00 – 19:00)	69	79	62	52	61	45
Evening (19:00 – 23:00)	64	68	62	49	54	44
Night-time (23:00 – 07:00)	63	68	60	47	54	43
24 h	67	79	60	51	61	43

Table 4.11: Environmental Noise (ecological receptors) Locations –Short-term Attended Noise Monitoring Results

ID	Date/Time	Height above grade (m)	L _{Ze} q (1-h) (dBZ)	L _A eq (1-h) (dBA)
AES-1	2015-09-18 / 15:24 (Daytime)	4.5	67	59
AES-1_2	2015-09-25 / 11:51 (Daytime)	4.5	64	51
AES-2	2015-09-18 / 12:43 (Daytime)	4.5	61	53
AES-2_2	2015-09-25 / 06:57 (Night-time)	1.5	65	49
AES-3	2015-09-18 / 13:29 (Daytime)	4.5	63	53

Similar to the human receptor noise data, noise levels were generally higher in the daytime than the evening and night-time periods at the Environmental Noise (ecological receptors) locations. Also, the noise levels during the ecological time period (06:00 (dawn) to 10:00) tended to be similar to those during the night-time period. It was generally observed on site that the local acoustic background consists of the sounds of road traffic, and residential maintenance and construction (i.e. lawn cutting, deck building). In areas near the shoreline, it was observed that the sounds of wave action dominate the acoustic environment. These sounds are consistent with the urban environment within which PN is located.

Noise levels at PN can potentially cause disturbance to wildlife. The Pickering B EA Terrestrial Environment TSD (Golder, 2007c) concluded that, although some wildlife may be sensitive to high noise levels, most wildlife in the area (onsite and offsite) are likely accustomed to noise levels associated with an urban environment, and have already acclimated to the noise levels in this specific environment as the PN facility has been fully operational for three decades. There is no specific noise level threshold for wildlife within official regulatory documents. Based on the discussion above, exposure of non-human biota to noise levels from PN is not discussed further.

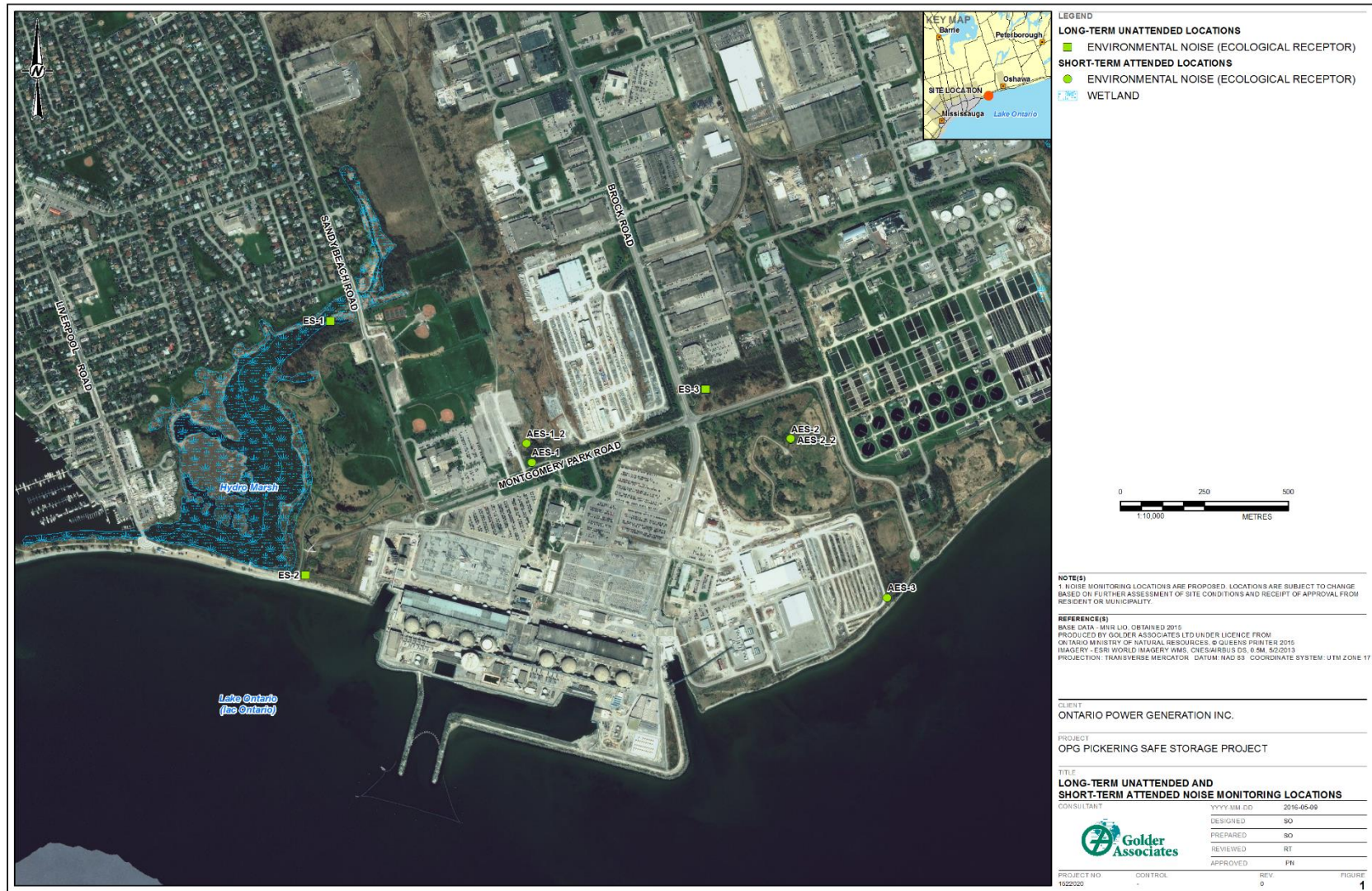

Figure 4.6: Environmental Noise (Ecological Receptors) - Long-term Unattended and Short-term Attended Noise Monitoring Locations

4.1.3.11.2 Thermal Stressors, Entrainment, Impingement

CSA N288.6-12 (CSA, 2012) recommends that thermal stressors and entrainment and impingement should be carried forward for assessment in the EcoRA since they are widely recognized as being of primary concern at nuclear power plants.

Under normal operations the 24 hour temperature difference limit in the ECA for PN is 11°C and the station effluent discharge temperature limit is 36°C from July 1 – October 31 and 32°C from November 1 to June 30. However, under special circumstances, namely algal events, and declared Electricity Supply Emergency event days, special ECA limits apply. During algal events, the Station Effluent Discharge Temperature Limit is 37°C and the temperature difference limit is 16°C (OPG, 2011j). The temperature limits for station effluent discharge under different operating conditions are shown in Table 4.12.

Table 4.12: Environmental Compliance Approval Discharge Temperature Limits for Different Operating Conditions (OPG, 2011j)

Operating Conditions	Period of Year	Effluent Temperature Limit	Temperature Difference Limit (ΔT)	Allowed Period of Operation	Total Number of Operating Days Limit Allowed
Normal	Jul 1 to Oct 31	36°C	11°C	continuous	N/A
	Nov 1 to Jun 30	32°C	11°C	continuous	N/A
Algae Impact Event	Jul 1 to Dec 31	37°C	16°C	Not to exceed 24 h for any single event	16
Declared Electrical Supply Emergency	Jul 1 to Oct 31	37°C	11°C	Not specified	15

The thermal impact from the CCW discharge becomes a concern during algae and ice buildup events. These occurrences require some CCW pumps to be turned off to reduce the pressure on the greenhouse travelling screens. This causes the temperature of the water being released at the outfall to be higher than when all the pumps are in operation. At times these algae and ice events have caused the temperature difference to exceed the ECA limit (OPG, 2012e; 2013f; 2014c; 2015g; 2016e).

In order to minimize the impact of the algae events, OPG has implemented mitigation measures and preventive actions. These include the following:

- Installation of a skirt in 2011 on the FDS surrounding the opening to the intake channel to prevent the weighing down of the FDS during severe algal events that allow algae and fish to travel over the screen.
- Installation of a new, more efficient Trash Trough Bar Screen designed to filter clumps of algae and reduce algae recirculation into the forebay.
- Optimization of the operability of existing equipment in the screenhouse by installing new cyclone separators to filter silt and by replacing travelling screen spray wash nozzles with larger diameter nozzles that are less likely to become plugged by debris.
- Improvements to the preventive maintenance program to increase the reliability of the travelling screens.

Mitigation of ice events included improvement in the Ice Barrier at the mouth of the intake channel. To reduce the severity of future ice events, the CCW operating manual was revised to include instructions to sequentially shut down one CCW pump per unit as required during an ice in forebay event rather than immediately shutting down one pump on all units. The operating manuals were also revised to add steps to increase the use of small steam release valves to prevent ice from developing on bar and travelling screens to reduce the risk of CCW pump trips.

Overall, the effect of the thermal plume at PN was carried forward and assessed in the EcoRA.

Since entrainment and impingement are known effects at PN, they were carried forward and assessed in the EcoRA.

4.1.3.11.3 Bird Strikes and Wildlife Collisions

Wildlife strikes with vehicles and bird/bat strikes on buildings are other physical stressors typically addressed in an ERA. These physical stressors have been previously addressed in the 2007 Pickering B EA (Golder, 2007c). Monitoring of wildlife mortality from vehicle strikes has been performed on the Pickering site as part of the Pickering A Return to Service EA Follow-Up and Monitoring Program (reported in Golder, 2007c). In 2006, 27 mortalities in 24 observation days were observed, which corresponds to 1.08 individual mortalities per observation day. Prior to Pickering A restart, 23 mortalities were observed in 27 days, which corresponds to 0.9 mortalities per observation day. Mortality rates have been fairly consistent over the years where data were collected. The species most commonly struck include the eastern grey squirrel, eastern cottontail, and European starling. Some species identified as VECs have been struck. None of the species recorded

as mortalities are considered species of concern. All of the VECs that have been recorded as mortalities are abundant in the vicinity of PN. Based on this observation, the EA states that no population level effects are expected to result from the loss of a few individuals at the low rate of mortality currently observed (Golder, 2007c).

From 2011 to 2015, approximately 20 bird strikes on buildings were recorded through voluntary reporting in Station Condition Records. However, numbers may be higher since this is through voluntary reporting. Data on bird and bat strikes against station buildings is limited; however, it is assumed that the rate is consistent with the number impinged on the wind turbine located on the shoreline next to Pickering. Since the number of birds and bats impinged on the wind turbine is low (4 birds and 8 bats over 1 calendar year) and there are a large number of birds and bats in the area, the EA states that no population level effects are expected to result from the loss of a few individuals. There are uncertainties associated with the assumed comparability of strike rates between the wind turbine and buildings, but the strike rates for buildings are unlikely to be substantially higher, and the rate for the wind turbine is of little consequence, so a similar finding for building strikes is reasonable.

According to the discussion above, wildlife strikes with vehicles, and bird and bat strikes on buildings, do not need to be carried forward for further consideration in the EcoRA.

4.1.3.12 Summary of COPC Selection for the EcoRA

Table 4.13 summarizes the radiological and non-radiological COPCs that are carried forward to the exposure assessment in the EcoRA.

Table 4.13: Summary of COPCs Selected for the Ecological Risk Assessment

Category	Radiological COPC	Non-Radiological COPC
Air	noble gases (represented by argon-41) (PN site)	None
Surface water	tritium, carbon-14, gross beta-gamma (represented by cobalt-60), cesium-134, cesium-137 (Lake and Frenchman's Bay)	hydrazine, total residual chlorine, morpholine, copper (Lake) sulphate (East Landfill Only) total aluminum, copper, iron, and sodium (Frenchman's Bay)
Groundwater	None	None
Stormwater	None	None
Sediment	carbon-14, cesium-134, cesium-137, cobalt-60 (Frenchman's Bay)	aluminum, bismuth, boron, cadmium, calcium, chromium, copper, lead, manganese, nickel, phosphorous, thorium, tin, zinc, total organic carbon (Frenchman's Bay)
Soil	tritium, carbon-14, cesium-134, cesium-137, cobalt-60 (PN site)	cyanide, arsenic, copper, lead, zinc, and petroleum hydrocarbon F4 (PN site)
Physical Stressor (Noise, Bird Strikes/Wildlife Collisions)	None	
Physical Stressors	impingement/entrainment	
	thermal plume	

4.1.4 Selection of Exposure Pathways

Exposure pathways include the routes of contaminant dispersion from the source to receptor location and the routes of contaminant transport through the food chain to the receptor organism. Both are considered, as appropriate to the species and location, using measured concentrations of COPCs wherever such data exist, and estimating concentrations where measured values are not available.

For fish, frog and aquatic plants, contact with water and contaminant uptake from water via bioaccumulation represents the main exposure pathway. For soil invertebrates and terrestrial plants, the main exposure pathway is through contact with soil and contaminant uptake from soil via bioaccumulation. The dominant exposure pathways for birds, mammals and turtles is through the uptake of contaminants via the ingestion of water, incidental ingestion of soil or sediment, and ingestion of food.

Airborne COPCs partition to soil and plants, and ingestion pathways dominate over inhalation and air immersion for most COPCs. The latter pathways will be omitted for ecological receptors in this assessment, except for noble gases, as noted in Section 4.1.3.5.

4.1.5 Ecological Conceptual Model

The conceptual model illustrates how receptors are exposed to COPCs. It represents the relationship between the source and receptors by identifying the source of contaminants, receptor locations and the exposure pathways to be considered in the assessment for each receptor. Exposure pathways represent the various routes by which radionuclides and/or chemicals may enter the body of the receptor, or (for radionuclides) how they may exert effects from outside the body. Table 4.14 summarizes the relevant exposure pathways for each type of ecological receptor. The conceptual model for the EcoRA is illustrated in Figure 4.7 and Figure 4.8. For completeness, the air exposure pathway is shown, but can usually be ignored since it is usually minor compared to the soil or sediment ingestion exposure (CSA, 2012). Exposures to noble gases in air can be important, since air is the dominant pathway in this case. In addition, the figures incorporate generalizations where, for the ease of representation, some VECS are grouped together by category. For example, all the pelagic fish, regardless of size and habits, are shown to be consumed by the tern and the Ring-billed Gull, although their diets would consist of differing types of fish.

The 2007 EcoRA to support the Pickering B Refurbishment and Continued Operation EA, assessed aquatic biota for non-radiological exposure at the Hydro Marsh. Historically, this location was assessed because there was a pipeline which discharged CCW from PN through a fish farm to the Hydro Marsh. This pipeline was disconnected in 1997, and follow-up field studies have shown there is no accumulation of radionuclides in the marsh, and contaminant accumulation patterns do not correlate with effluent from the PN site (SENES, 2007a). Without the pipeline, it is unlikely that PN has an influence on the water and sediment quality at the Hydro Marsh. The marsh is considered not exposed to PN operations because it is separated from Lake Ontario by a barrier beach, and receives water inflow from Krosno Creek and municipal storm sewers.

Frenchman's Bay is a provincially significant wetland, is designated an Environmentally Sensitive Area by the TRCA, and is an Aquatic Biology Core Area. Frenchman's Bay is a habitat for wetland vegetation, mainly cattails, benthic invertebrates, fish, and wildlife. Frenchman's Bay is Hydro Marsh's link to Lake Ontario, and water from the lake enters the system when the water level rises in Lake Ontario (Golder, 2007b). Therefore, Frenchman's Bay is more likely to be impacted by non-radiological and radiological waterborne discharges from PN operations, and provides a habitat for all the VEC species identified in Table 4.14. This includes the habitat for the Red-winged Blackbirds that use the wetland as a source of food and nesting habitat, primarily among the cattails (SENES, 2007a). The wetland is located in the northern section of the bay. Sediment and water data are available from both the northern and southern sections of Frenchman's Bay. In addition, although the Hydro Marsh experiences airborne deposition from atmospheric emissions from PN, tritium in air concentrations from the EMP reports show that the difference in dispersion factors between Hydro Marsh and Frenchman's Bay is minor. Therefore, Frenchman's Bay is a suitable location to assess riparian and aquatic receptors.

All the avian receptors to be assessed are migratory, and are likely to reside at the PN site for half of the year. However, for the exposure assessment, their occupancy at the site is assumed to be for the whole year.

Fish are abundant in the discharge channel, which provides a spawning habitat for Smallmouth Bass. There is also very sparse vegetation cover along the discharge channel (Golder, 2007b). Due to the prevalence of fish at the discharge channel, fish are assessed at the outfall.

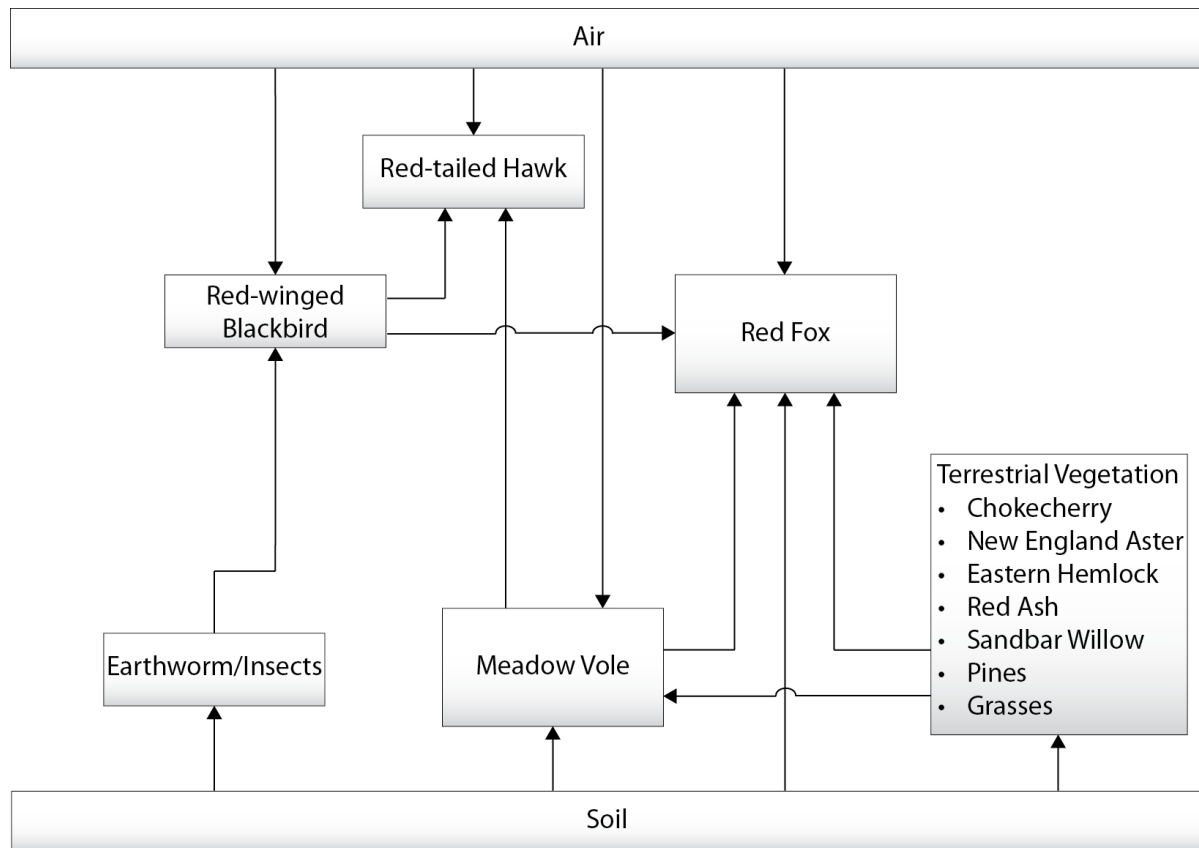

* Although not shown on the figure, all terrestrial birds and mammals drink water.

Figure 4.7: Conceptual Model for the Terrestrial Environment

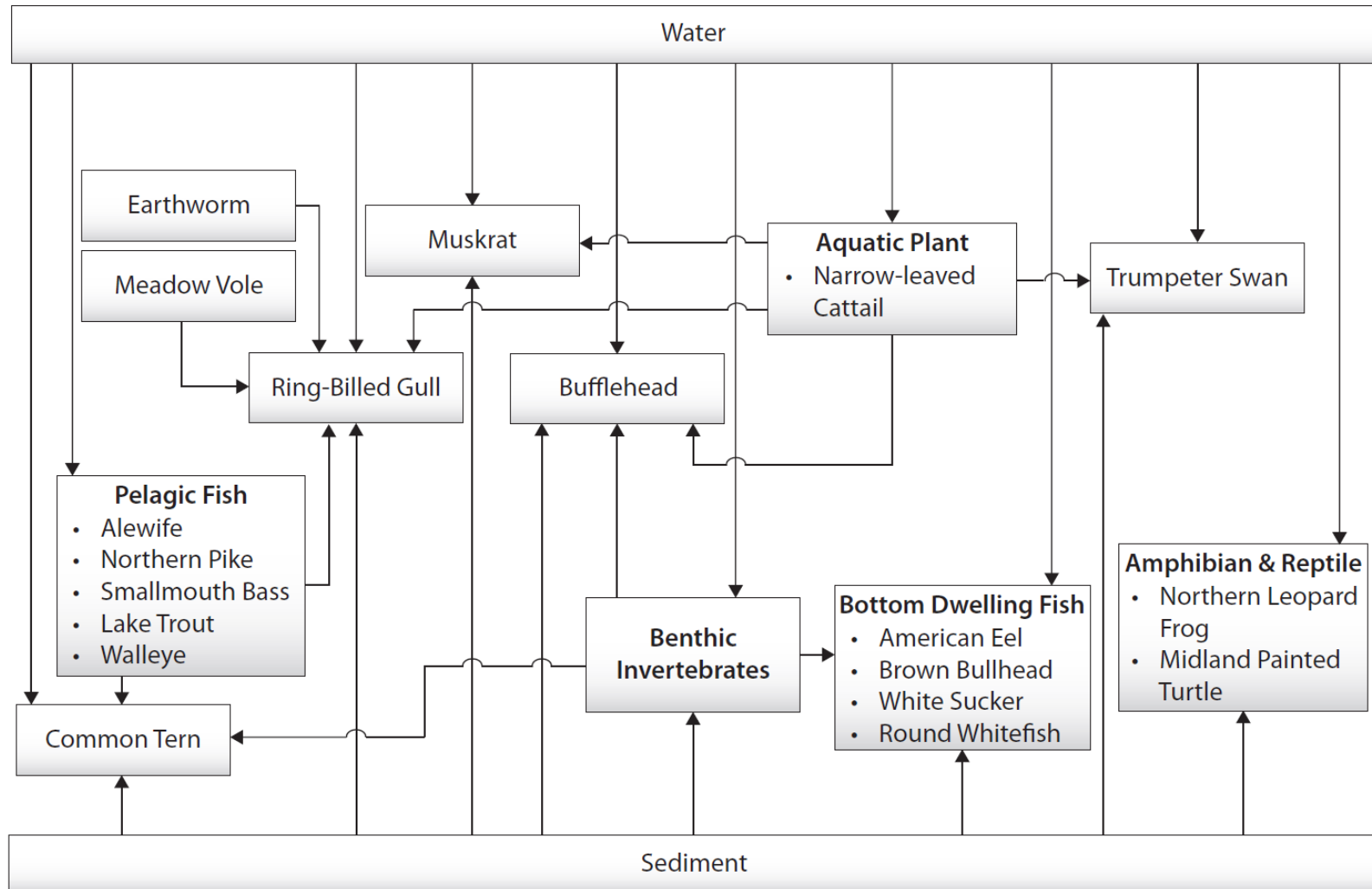

Note:

Riparian birds and mammals (i.e., muskrat) are exposed to air immersion which is not shown in the figure.

Figure 4.8: Conceptual Model for the Aquatic Environment

Table 4.14: Complete Exposure Pathways for All Selected VEC Species

VEC Category	Location	VEC	Exposure Pathways	Environmental Media		
Bottom Feeding Fish	Outfall Frenchman's Bay	Brown Bullhead	Direct Contact	Water Sediment		
		Round Whitefish	Direct Contact	Water Sediment		
		White Sucker	Direct Contact	Water Sediment		
		American Eel	Direct Contact	Water Sediment		
Pelagic Fish	Outfall Frenchman's Bay	Alewife	Direct Contact	Water		
		Smallmouth Bass	Direct Contact	Water		
		Northern Pike	Direct Contact	Water		
		Lake Trout	Direct Contact	Water		
		Walleye	Direct Contact	Water		
Amphibians and Reptiles	Frenchman's Bay	Northern Leopard Frog	Direct Contact	Water Sediment		
		Midland Painted Turtle	Direct Contact	Water Sediment		
Aquatic Plants	Frenchman's Bay	Narrow-leaved cattail	Direct Contact	Water		
Aquatic Invertebrates	Outfall Frenchman's Bay	Benthic Invertebrates	Direct Contact	Sediment		
Riparian Birds	Frenchman's Bay	Trumpeter Swan	Immersion	Air		
			Ingestion	Water Sediment Aquatic Plant		
		Ring-billed Gull	Immersion	Air		
			Ingestion	Water Sediment Aquatic Plant Fish Earthworm Mammals		
		Common Tern	Immersion	Air		
			Ingestion	Water Sediment Benthic Invertebrate Fish		
		Bufflehead	Immersion	Air		
			Ingestion	Water Sediment Benthic Invertebrate Aquatic Plants		
		Riparian Mammals	Frenchman's Bay	Muskrat	Immersion	Air
					Ingestion	Water Sediment Aquatic Plant
		Terrestrial Plants	Pickering Nuclear site	Chokecherry	Immersion	Air
					Direct Contact	Soil
New England aster	Immersion			Air		
	Direct Contact			Soil		
Eastern hemlock	Immersion			Air		
	Direct Contact			Soil		
Red ash	Immersion	Air				

VEC Category	Location	VEC	Exposure Pathways	Environmental Media
			Direct Contact	Soil
		Sandbar willow	Immersion	Air
			Direct Contact	Soil
		Pine/Grass	Immersion	Air
			Direct Contact	Soil
Terrestrial Invertebrates	Pickering Nuclear site	Earthworms	Direct Contact	Soil
Terrestrial Birds	Pickering Nuclear site	Red-winged Blackbird	Immersion	Air
			Ingestion	Insects Soil Water
		Red-tailed Hawk	Immersion	Air
			Ingestion	Birds Mammals Soil Water
Terrestrial Mammals	Pickering Nuclear site	Red Fox	Immersion	Air
			Ingestion	Soil Terrestrial Vegetation Mammals Birds Water
		Meadow Vole	Immersion	Air
			Ingestion	Soil Terrestrial Vegetation Water

For organism losses by entrainment/impingement, the conceptual model illustrated in CSA N288.6-12 (CSA, 2012) is appropriate. This conceptual model (Figure 4.9) represents the relationship between the individual losses and possible population or community effects.

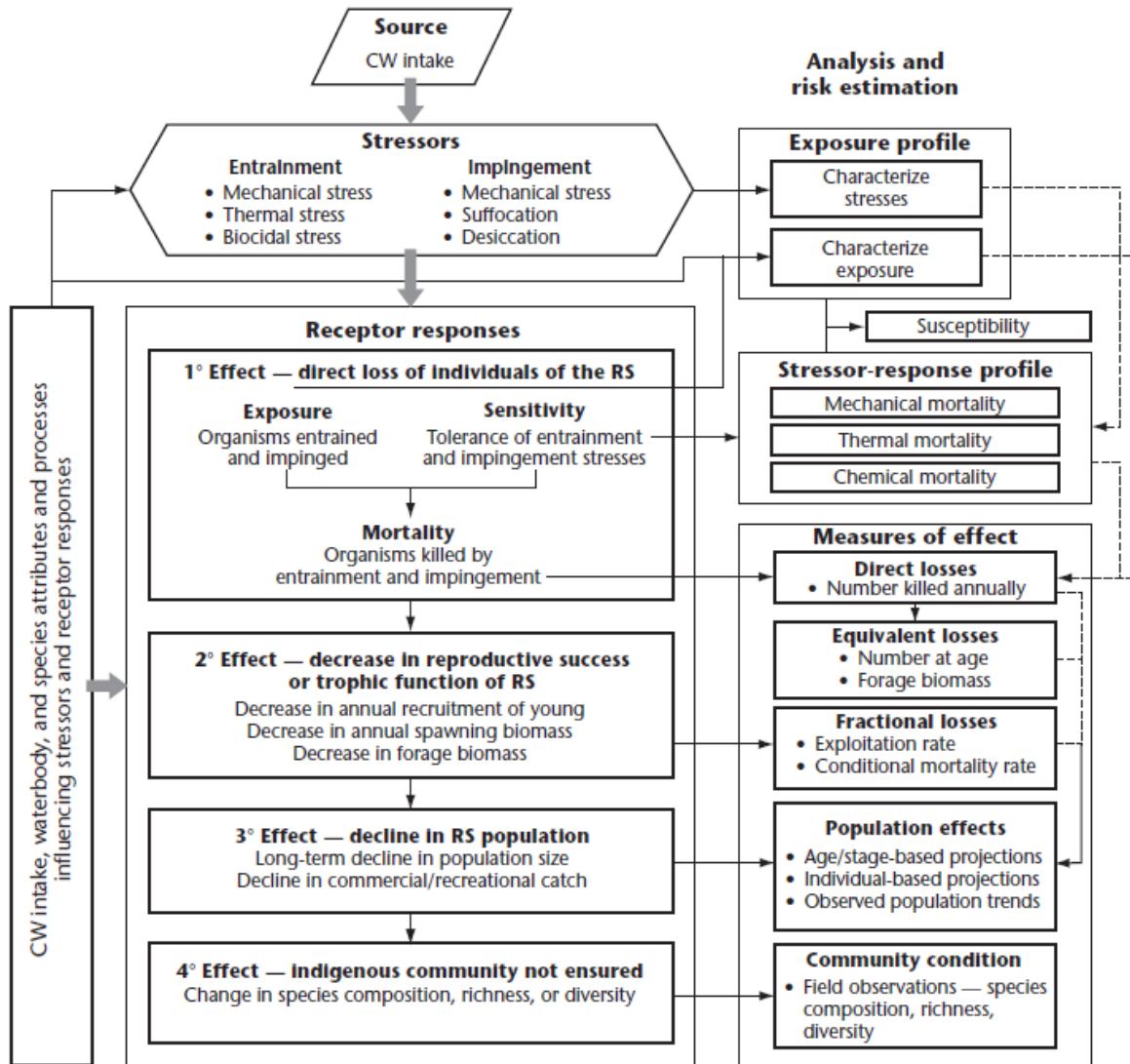

Figure 4.9: Generic Conceptual Model for Relationships between Individual Endpoints and Population/Community Endpoints (CSA, 2012)

4.2 Exposure Assessment

4.2.1 Exposure Points

Measured concentrations of COPCs for the various media at the receptor locations listed in Table 4.14 were generally available. The exposure concentrations at the exposure locations

are further described in Section 4.2.5 and in Table 4.27. The majority of the exposure point concentrations were obtained from:

- 2015 baseline environmental monitoring program for surface water, sediment, soil;
- OPG Annual EMP reports (years 2011 to 2015); and
- Effluent concentrations (years 2011 to 2015).

4.2.2 Exposure Averaging

4.2.2.1 Exposure Averaging

When multiple measurements and samples were available for a given COPC in a particular medium at an assessed exposure location, the arithmetic average as well as maximum concentrations were calculated based on the available data. Birds and mammals are likely to experience something close to average concentrations as they move around the area. However, for less mobile organisms such as plants and invertebrates, both average and upper limit concentrations represent exposures that would be experienced by some organisms on a long term basis.

4.2.2.2 Environmental Partitioning

Water:sediment partitioning was estimated as described below in activity units:

$$C_{s(fw)} = \frac{\theta \cdot C_w \cdot \rho_w + (1-\theta) \cdot C_w \cdot K_d \cdot \rho_s}{\theta \cdot \rho_w + (1-\theta) \cdot \rho_s}$$

$$C_{s(dw)} = C_{s(fw)} / f_{dw}$$

$$f_{dw} = \frac{(1-\theta) \cdot \rho_s}{\theta \cdot \rho_w + (1-\theta) \cdot \rho_s}$$

where,

$C_{s(fw)}$	=	concentration in sediment (Bq/kg FW)
C_w	=	concentration in water (Bq/L)
ρ_w	=	density of water (1 kg/L)
θ	=	sediment porosity (unitless)
K_d	=	distribution coefficient (L/kg solid)
ρ_s	=	density of solids (kg/L)
$C_{s(dw)}$	=	concentration in sediment (Bq/kg DW)
f_{dw}	=	dry weight fraction of sediment (unitless).

For COPCs without sediment data, the sediment distribution coefficients (K_d) used in the environmental partitioning calculations are listed in Table 4.15. For COPCs that do not have a sediment K_d in CSA (2014) or IAEA (2010), the soil K_d found in IAEA (2010) was used. The soil K_d is multiplied by a factor of 10 to take into account the typically higher water content (water filled porosity) in sediment and greater available particle surface area for adsorption. The sediment porosity and sediment density at the PN site is assumed to be 0.1 and 1.5 kg/L (for sand) respectively (CSA, 2014). At Frenchman's Bay, since measured moisture content was available for sediment samples collected in 2015, the sediment porosity was 0.6, the average moisture content from all sediment samples.

Table 4.15: Sediment Distribution Coefficients

COPC	Distribution Coefficient (K_d) (L/kg dw)	Reference
Tritium	0	CSA, 2014
Carbon-14	50	CSA, 2014
Cobalt-60	43,000	CSA, 2014
Cesium-134	9,500	CSA, 2014
Cesium-137	9,500	CSA, 2014
Chlorine (TRC)	0	see text below
Copper	2,700	IAEA, 2010 (soil value x 10)
Hydrazine	0	See text below
Morpholine	0	See text below

The environmental partitioning of hydrazine was modeled and described in EC/HC (2011). The modeling results show that when hydrazine is released to surface water, it will remain almost entirely in the water (99.9% in water, 0.02% in sediment). Based on these results, the partitioning of hydrazine from water to sediment is negligible as the K_d is 0 L/kg dw. Due to morpholine's solubility in water, when it is released into the environment, it moves with soil moisture and water, and does not sorb to sediment or organic matter (Lewis *et al.* as cited in Poupin *et al.* 1998). Therefore, the K_d for morpholine for this assessment is 0 L/kg dw. TRC is not expected to be measurable in sediment or soil because it reacts and volatilizes rapidly (ATSDR, 2010). Sulphate is assessed qualitatively and does not require a K_d .

4.2.3 Exposure and Dose Calculations

Exposure and dose calculations for each COPC were performed for the ecological receptors and receptor locations outlined in the ecological conceptual model (Section 4.1.5).

4.2.3.1 Radiological Dose Calculations

The radiation doses for the aquatic biota were estimated using the methods outlined in CSA N288.6-12 (CSA, 2012). The dose for each radionuclide is comprised of an internal dose component, and an external dose component, which is driven by water and sediment. The 0.5 in the equation is for semi-infinite exposure to activity in water, for the time the organism spends at water surface, and a semi-infinite exposure to activity in sediment, for the time the organism spends at sediment surface. The aquatic biota dose was calculated using the following equations:

$$D_{int} = DC_{int} \cdot C_t$$

$$D_{ext} = DC_{ext} \cdot [(OF_w + 0.5 \cdot OF_{ws} + 0.5 \cdot OF_{ss}) \cdot C_w + (OF_s + 0.5 \cdot OF_{ss}) \cdot C_s]$$

where,

D_{int}	=	internal radiation dose ($\mu\text{Gy/d}$)
D_{ext}	=	external radiation dose ($\mu\text{Gy/d}$)
DC_{int}	=	internal dose conversion factor ($(\mu\text{Gy/d})/(\text{Bq/kg})$)
DC_{ext}	=	external dose coefficient ($(\mu\text{Gy/d})/(\text{Bq/kg})$)
C_t	=	whole body tissue concentration (Bq/kg fw)
C_w	=	water concentration (Bq/L)
C_s	=	sediment concentration (Bq/kg fw)
OF_w	=	occupancy factor in water (unitless)
OF_{ws}	=	occupancy factor at water surface (unitless)
OF_{ss}	=	occupancy factor at sediment surface (unitless)
OF_s	=	occupancy factor in sediment (unitless)

For riparian biota that have both an on soil (sediment) and a water external dose coefficient, such as the muskrat and waterbirds, the external dose component was calculated as follows:

$$D_{ext} = DC_{ext,w} \cdot OF_w \cdot C_w + DC_{ext,s} \cdot OF_{ss} \cdot C_s$$

where,

$DC_{ext,w}$	=	external dose coefficient (in water)
$DC_{ext,s}$	=	external dose coefficient (on sediment)
C_w	=	water concentration (Bq/L)
C_s	=	sediment concentration (Bq/kg fw)
OF_w	=	occupancy factor in water (unitless)
OF_{ss}	=	occupancy factor on sediment surface (unitless)

The radiation dose to terrestrial biota is estimated using a method similar to that for riparian biota, except the external dose component is driven by soil rather than water and sediment. The equations used to estimate radiation dose are:

$$D_{\text{int}} = DC_{\text{int}} \cdot C_t$$

$$D_{\text{ext}} = DC_{\text{ext},s} \cdot OF_s \cdot C_s + DC_{\text{ext},ss} \cdot OF_{ss} \cdot C_s$$

where,

DC_{int}	=	internal dose coefficient (($\mu\text{Gy/d}$)/(Bq/kg))
$DC_{\text{ext},s}$	=	external dose coefficient (in soil) (($\mu\text{Gy/d}$)/(Bq/kg))
$DC_{\text{ext},ss}$	=	external dose coefficient (on soil surface) ($\mu\text{Gy/d}$)/(Bq/kg)
C_t	=	whole body tissue concentration (Bq/kg fw)
C_s	=	soil concentration (Bq/kg dw)
OF_s	=	occupancy factor in soil (unitless)
OF_{ss}	=	occupancy factor at soil surface (unitless)

The total radiation dose to biota is the sum of the internal and external dose components for each radionuclide ($D_{\text{int}} + D_{\text{ext}}$). External exposure through the air immersion and inhalation pathway are considered to be minor compared to the ingestion pathway, and were ignored, with the exception of noble gases (CSA, 2012). The external dose due to argon-41 was assessed for the terrestrial biota by directly applying the absorbed dose value from the air kerma presented in OPG's annual EMP reports. The dose coefficients and occupancy factors used in the radiological dose estimation are provided in Section 4.2.3.4.

4.2.3.2 Non-Radiological Dose Calculations

The non-radiological dose (D_{ing}) for mammals and birds was estimated using the methods described in CSA (2012), and is as follows:

$$D_{\text{ing}} = \sum C_x \cdot I_x / W$$

where,

C_x	=	concentration in the ingested item (x) (mg/kg)
I_x	=	ingestion rate of item x (kg/day)
W	=	body weight of consumer (kg fw)

For receptors that drink from contaminated water, such as the muskrat drinking from Frenchman's Bay, the drinking water component was considered. The concentrations in the water and the ingestion rate were in units of volume. In addition, for receptors that have incidental contaminated soil or sediment ingestion, this pathway was considered on a dry weight basis. Other ingested items (foods) were considered on a fresh weight basis. As with

the radiological dose calculations, inhalation exposure is considered minor compared to the ingestion exposure, and was ignored (CSA, 2012).

4.2.3.3 Tissue Concentration Calculations

The tissue concentrations (C_t) for plants, invertebrates or fish were derived using bioaccumulation factors (BAFs), as per CSA (2012) as follows:

$$C_t = C_m \cdot \text{BAF}$$

where,

- C_t = whole body tissue concentration (Bq/kg fw)
- C_m = media concentration (Bq/L or Bq/kg)
- BAF = bioaccumulation factor (L/kg or kg/kg)

For birds and mammals, tissue concentrations were estimated using transfer factors (TFs), or biomagnification factors (BMFs) and the concentrations in their food, as follows:

$$C_t = \sum C_x \cdot I_x \cdot \text{TF} = C_f \cdot \text{BMF}$$

where,

- C_x = concentration in the ingested item x (Bq/kg fw)
- I_x = ingestion rate of item x (kg fw/d)
- TF = ingestion transfer factor (d/kg)
- C_f = average concentration in food (Bq/kg fw)
- BMF = biomagnification factor (unitless)

The BMF is equivalent to the total food intake rate times the transfer factor:

$$\text{BMF} = \sum I_x \cdot \text{TF}$$

The BAFs, TFs and ingestion rates used for the calculation of tissue concentrations in biota are further described in Section 4.2.3.4.

4.2.3.4 Exposure Factors

There are several COPC- and biota-specific exposure factors required for the dose calculations discussed in Section 4.2.3. These parameters include intake rates, body weights, occupancy factors, BAFs, TFs, and dose coefficients (DCs).

4.2.3.4.1 Body Weight and Intake Rates

The body weight and intake rates are required for the calculation of exposure to birds and mammals. The body weights and total feed intake rates were taken from the 2000 ERA

(SENES, 2000), where the assumptions and values were considered to be applicable. For receptors not assessed in the 2000 ERA (SENES, 2000), body weights were found in literature, and feed intake rates were proportioned to body weight using allometric equations from the US EPA (US EPA, 1993). The water intake and inhalation rates were determined using allometric equations for all birds and mammals. The incidental ingestion of soil and sediment was estimated based on the feed intake. The incidental ingestion varied from 2% to 10.4% of dry weight food intake depending on the biota. The values are summarized in Table 4.16.

Table 4.16: Bird and Mammal Body Weights and Intake Rates

Receptor	Body weight kg	Total Feed Intake		Dietary Components	Feed Type Fraction	Feed Intake		% Moisture ¹	Intake of Soil/Sediment ² %	Total Soil/Sediment kg DW/d	Water Intake kg/d	Inhalation m ³ /d
		kg/d dw	kg/d fw			kg/d dw	kg/d fw					
Trumpeter Swan	11.0	0.347	1.386	aquatic plants	1	0.347	1.386	75%	3.3%	1.14E-02	0.294	2.591
Ring-billed Gull	0.700	0.050	0.193	aquatic plant	0.2	0.010	0.040	75%	3.3%	1.64E-03	0.046	0.311
			fish	0.6	0.030	0.120	75%					
			soil invert	0.1	0.005	0.017	70%					
			small mammals	0.1	0.005	0.017	70%					
Common Tern	0.125 ³	0.015	0.060	fish	0.9	0.014	0.054	75%	2%	3.01E-04	0.015	0.082
			benthic invert	0.1	0.002	0.006	75%					
Bufflehead	0.473 ⁴	0.045	0.179	aquatic plant	0.1	0.004	0.018	75%	10.4%	4.65E-03	0.036	0.230
			benthic invert	0.9	0.040	0.161	75%					
Muskrat	1.18	0.088	0.353	aquatic plant	1.0	0.088	0.353	75%	3.3%	2.91E-03	0.114	0.621
Red-winged Blackbird	0.055 ⁵	0.009	0.029	Insects (soil invert)	1	0.009	0.029	70%	7.3%	6.39E-04	0.008	0.044
Red-tailed Hawk	1.22	0.066	0.221	birds	0.27	0.018	0.060	70%	3.3%	2.19E-03	0.068	0.478
			small mammals	0.73	0.048	0.162	70%					
Red Fox	4.54	0.088	0.313	small mammals	0.5	0.047	0.157	70%	2.8%	2.45E-03	0.386	1.831
			riparian bird	0.3	0.028	0.094	70%					
			vegetation	0.2	0.013	0.063	80%					
Meadow Vole	0.034	0.002	0.011	vegetation	1	0.002	0.011	80%	2.4%	5.28E-05	0.005	0.036

Notes:

Data is from SENES (2000), unless otherwise indicated

¹ CSA, 2014

² Beyer *et al.*, 1994

³ Cuthbert *et al.*, 2003

⁴ NatureServe, 2013

⁵ Ministry of the Environment, 2009

4.2.3.4.2 Occupancy Factors

The fraction of time the biota resides in the PN site area, as discussed in Section 4.2.2, is assumed to be one. An occupancy factor is defined as the fraction of time the receptor species spends in or on various media. The occupancy factors, where available, are those in the previous ERA (SENES 2000, SENES 2001). For new biota, the occupancy factors are based on the experience and judgement of the risk assessor and the known behaviour of the receptor. The occupancy factors used in the radiological dose estimation are given in Table 4.17, and are applied to the equations discussed in Section 4.2.3.1.

Table 4.17: Receptor Occupancy Factors

Aquatic Biota	OF_s	OF_{ss}	OF_w	Terrestrial Biota	OF_s	OF_{ss}
Bottom Dwelling Fish		0.5	0.5	Terrestrial Plant		1
Pelagic Fish			1	Earthworm	1	
Amphibians		0.5	0.5	Red-winged Blackbird		1
Benthic Invertebrates	1			Red-tailed Hawk		1
Aquatic Plants			1	Meadow Vole		1
Riparian Birds		0.5	0.5	Red Fox	0.2	0.8
Muskrat		0.5	0.5			

Notes:

OF_s = occupancy factor in soil/sediment

OF_{ss} = occupancy factor on soil/sediment surface

OF_w = occupancy factor in water

4.2.3.4.3 Bioaccumulation Factors

Bioaccumulation factors relate the COPCs in the environmental media to the concentration in the receptor. Since tissue concentrations were not available for the receptors at the PN site, BAFs were used to calculate COPC concentrations in plant, invertebrate and fish tissues. These factors vary throughout the literature. For the exposure assessment, BAFs were taken from CSA (2014), IAEA (2010) and literature sources, including those suggested in CSA N288.6-12 (CSA, 2012). The BAFs used in the assessment are presented in Table 4.18 and Table 4.19. Bioaccumulation factors for tritium and carbon-14 are calculated using the specific activity model, which is discussed in Section 4.2.3.4.6 and 4.2.3.4.7. As discussed in Section 3.2.4 of the HHRA, the fish BAF for hydrazine and morpholine is based on a QSAR model by Meylan et al. 1999 (as cited in European Commission, 2006). There are no other hydrazine and morpholine BAFs available for other aquatic biota. No BAFs are presented for total residual chlorine as chlorine does not bioaccumulate in plants or animals (ATSDR, 2010).

For cyanide and petroleum hydrocarbon F4, BAFs for transfer from soil to soil invertebrates and terrestrial plants are not warranted as these parameters do not bioaccumulate through the food chain (CCME, 1997, 2008).

Table 4.18: Bioaccumulation Factors (BAFs) for Fish, Amphibians, Benthic Invertebrates, and Aquatic Plants (L/kg fw)

COPC	Fish	Amphibian	Benthic Invertebrate	Aquatic Plant
Cobalt-60	5.40E+01 ¹	5.40E+01 ¹	1.10E+02 ¹	7.90E+02 ¹
Cesium-134	3.50E+03 ¹	3.50E+03 ¹	9.90E+01 ¹	2.20E+02 ¹
Cesium-137	3.50E+03 ¹	3.50E+03 ¹	9.90E+01 ¹	2.20E+02 ¹
Hydrazine	3.16E+00 ²	nd	nd	nd
Morpholine	3.16E+00 ²	nd	nd	nd
Copper	2.70E+02 ³	2.70E+02 ³	4.20E+01 ³	3.00E+03 ³
Aluminum	6.6E+01 ³	6.6E+01 ³	3.4E+03 ³	8.33E+02 ⁴
Sodium	8.40E+00 ¹	8.40E+00 ¹	7.3E+00 ¹	1.8E+01 ¹
Iron	2.40E+02 ¹	2.40E+02 ¹	2.8E+03 ¹	3.1E+03 ¹

Notes:

nd = no data available

¹ CSA, 2014

² European Commission, 2006

³ IAEA, 2010

⁴ Thompson et al, 1972

Table 4.19: Bioaccumulation Factors (BAFs) for Soil Invertebrates and Terrestrial Plants (kg-dw/kg-fw)

COPC	Soil Invertebrate	Terrestrial Plant
Cobalt-60	6.08E-03 ⁴	8.93E-03 ²
Cesium-134	8.94E-02 ⁴	1.01E-02 ³
Cesium-137	8.94E-02 ⁴	1.01E-02 ²
Arsenic	4.43E-02 ¹	4.75E-02 ²
Copper	1.40E-01 ¹	1.52E-01 ³
Lead	9.21E-02 ¹	4.37E-03 ³
Zinc	7.45E-01 ¹	2.47E-01 ²

Notes:
¹ Sample *et al.*, 1998

² CSA, 2014

³ IAEA, 2010

⁴ Beresford, 2008

4.2.3.4.4 Transfer Factors

Transfer factors represent the fraction of daily COPC intake transferred to the tissue of birds and mammals. Ingestion transfer factors are COPC and biota-specific. Transfer factors from feed to tissue for agricultural livestock are available in CSA (2014). An allometric equation (transfer proportional to a $-3/4$ power of body weight) (CSA, 2012), was applied to transfer factors available for beef, rabbit and poultry, to estimate the transfer factors for the bird and mammal receptors. The derived transfer factors are presented in

Table 4.20 and Table 4.21. The transfer factors for tritium and carbon-14 were derived using specific activity methods, which are discussed in Section 4.2.3.4.6 and 4.2.3.4.7.

The CCME (1997) indicates that cyanide does not bioaccumulate in any organisms, but is rapidly degraded by organisms at low doses. As such, the major route of exposure to cyanide for mammals and birds is through soil ingestion.

A transfer factor for petroleum hydrocarbon F4 is also not warranted. The CCME (2008) argues that petroleum hydrocarbons do not accumulate in tissues of plants, mammals and birds. Most petroleum hydrocarbons are quickly metabolized and modified for release from the body. The major route of exposure to petroleum hydrocarbons for mammals and birds is through soil ingestion and not through consumption of plants and other animals.

Table 4.20: Transfer Factors for Riparian Birds and Mammals (d/kg fw)

COPC	Trumpeter Swan	Ring-Billed Gull	Common Tern	Bufflehead	Muskrat
Cobalt-60	2.70E-01	2.13E+00	7.76E+00	2.86E+00	4.62E-02
Cesium-134	7.52E-01	5.93E+00	2.16E+01	7.96E+00	2.36E+00
Cesium-137	7.52E-01	5.93E+00	2.16E+01	7.96E+00	2.36E+00
Copper	8.09E-02	6.38E-01	2.32E+00	8.56E-01	7.36E-01
Iron	3.90E-01	3.08E+00	1.12E+01	4.13E+00	1.50E+00
Sodium	1.95E+00	1.54E+01	5.60E+01	2.06E+01	1.61E+00
Aluminum	N/A	N/A	N/A	N/A	1.61E-01

Notes:

There were no data available to determine transfer factors for hydrazine and morpholine
 Radionuclide, iron and sodium transfer factors were derived from beef and poultry transfer factors from CSA (2014)
 Aluminum transfer factor was derived from beef from ATSDR (2008)
 Copper transfer factors were derived from beef and poultry from Sheppard (2009)

Table 4.21: Transfer Factors for Terrestrial Birds and Mammals (d/kg fw)

COPC	Red-winged Blackbird	Red-tailed Hawk	Meadow vole	Red fox
Cobalt-60	1.45E+01	1.40E+00	6.61E-01	1.68E-02
Cesium-134	4.03E+01	3.90E+00	3.38E+01	8.58E-01
Cesium-137	4.03E+01	3.90E+00	3.38E+01	8.58E-01
Arsenic	1.79E+01	N/A	3.08E+01	N/A
Copper	4.33E+00	N/A	1.05E+01	N/A
Lead	6.03E+00	N/A	1.08E+00	N/A
Zinc	7.01E+00	N/A	2.46E+02	N/A

Notes:

Transfer factors for non-radionuclides were not required for Red-tailed Hawk and red fox, since tissue concentrations were not required for the exposure calculation.

Radionuclide transfer factors were derived from rabbit and poultry transfer factors from CSA (2014)

Arsenic transfer factors were derived from beef and poultry (CSA, 2014)

Lead (for mammals), and zinc transfer factors were derived from beef and poultry (IAEA, 2010)

Copper and lead (for birds) transfer factors were derived from beef and poultry (Sheppard, 2009)

4.2.3.4.5 Dose Coefficients

Radiation dose coefficients (DCs) used for terrestrial and aquatic biota are shown in Table 4.22. These DCs were taken from ICRP (2008) and the ERICA Tool (2011). The surrogate species from these sources were selected to represent the indicator species, considering similarities in body size and likely external exposure media. The DC values for tritium in both sources (ICRP, 2008 and ERICA Tool, 2011) do not incorporate radiation quality factors for relative biological effectiveness (RBE). Therefore, the “low beta” components of the DCs were multiplied by 2 (as per CSA N288.6-12) in order to represent its greater relative effectiveness.

Table 4.22: Dose Coefficients of Surrogate Receptors Used for Radiological Exposure Calculations

Radionuclide	Earthworm		Shrub		Insect Larvae		Vascular Plant	
	Internal DC ($\mu\text{Gy/d}/(\text{Bq/kg})$)	External DC (in soil) ($\mu\text{Gy/d}/(\text{Bq/kg})$)	Internal DC ($\mu\text{Gy/d}/(\text{Bq/kg})$)	External DC ($\mu\text{Gy/d}/(\text{Bq/kg})$)	Internal DC ($\mu\text{Gy/d}/(\text{Bq/kg})$)	External DC ($\mu\text{Gy/d}/(\text{Bq/kg})$)	Internal DC ($\mu\text{Gy/d}/(\text{Bq/kg})$)	External DC ($\mu\text{Gy/d}/(\text{Bq/kg})$)
Tritium	1.38E-04	0.00E+00	1.39E-04	0.00E+00	1.39E-04	5.76E-12	1.39E-04	4.32E-08
Carbon-14	6.80E-04	0.00E+00	6.72E-04	0.00E+00	6.72E-04	1.97E-05	6.48E-04	2.64E-05
Cobalt-60	1.80E-03	3.10E-02	1.78E-03	1.08E-02	1.25E-03	3.36E-02	1.25E-03	3.36E-02
Cesium-134	2.60E-03	2.00E-02	2.40E-03	6.96E-03	1.73E-03	2.21E-02	1.66E-03	2.21E-02
Cesium-137	3.40E-03	7.30E-03	3.36E-03	2.64E-03	2.35E-03	8.88E-03	2.35E-03	8.88E-03

Radionuclide	Rat			Trout	
	Internal DC ($\mu\text{Gy/d}/(\text{Bq/kg})$)	External DC (on soil) ($\mu\text{Gy/d}/(\text{Bq/kg})$)	External DC (in soil) ($\mu\text{Gy/d}/(\text{Bq/kg})$)	Internal DC ($\mu\text{Gy/d}/(\text{Bq/kg})$)	External DC (in water) ($\mu\text{Gy/d}/(\text{Bq/kg})$)
Tritium	1.38E-04	0.00E+00	0.00E+00	1.38E-04	8.50E-12
Carbon-14	6.80E-04	0.00E+00	0.00E+00	6.80E-04	4.40E-07
Cobalt-60	4.00E-03	1.20E-02	2.90E-02	5.10E-03	3.10E-02
Cesium-134	4.10E-03	7.40E-03	1.90E-02	4.90E-03	1.90E-02
Cesium-137	4.10E-03	2.70E-03	6.80E-02	4.40E-03	6.80E-03

Radionuclide	Tadpole		Duck		
	Internal DC ($\mu\text{Gy/d}$)/(Bq/kg)	External DC (in water) ($\mu\text{Gy/d}$)/(Bq/kg)	Internal DC ($\mu\text{Gy/d}$)/(Bq/kg)	External DC (on soil) ($\mu\text{Gy/d}$)/(Bq/kg)	External DC (in water) ($\mu\text{Gy/d}$)/(Bq/kg)
Tritium	1.38E-04	3.20E-10	1.38E-04	0.00E+00	8.50E-12
Carbon-14	6.80E-04	5.50E-06	6.80E-04	0.00E+00	4.30E-07
Cobalt-60	1.50E-03	3.40E-02	5.70E-03	1.10E-02	3.00E-02
Cesium-134	2.30E-03	2.20E-02	5.30E-03	7.00E-03	1.90E-02
Cesium-137	3.20E-03	8.10E-03	4.50E-03	2.60E-03	6.70E-03

Notes:

Earthworm, rat, trout, tadpole and duck DCs from ICRP (2008)

Shrub, insect larvae and vascular plant DCs from ERICA Tool (Brown *et al.* 2008)

Shrub is the surrogate species for all terrestrial plants, insect larvae used for benthic invertebrates, vascular plants for aquatic plants, rat for mammals, and duck for all birds.

Noble gases are assessed using measured values from OPG's EMP and do not require DCs.

4.2.3.4.6 Specific Activity Model for Tritium

For tritium and carbon-14, tissue concentrations were calculated using specific activity models, as recommended in Clause 7.3.4.3.7 of CSA N288.6-12 (CSA, 2012). Aquatic BAFs for tritium assume that the specific activity in the aqueous component of the aquatic animal or plant is the same as the specific activity in the water. BAFs are used to calculate tritium concentrations in plant, invertebrate and fish tissues. Therefore the BAF (L/kg-fw) is:

$$\text{BAF}_{a_HTO} = 1-DW_a$$

or

$$\text{BAF}_{p_HTO} = 1-DW_p$$

where,

$1-DW_a$ = water content of the animal (L water /kg-fw)

$1-DW_p$ = water content of the plant (L water /kg-fw plant)

The transfer of tritium from soil to plant ($P_{HTOsoil_plant}$, kg-dw/kg-fw) is based on the ratio of the transfer of tritium from air to plant and the transfer of tritium from air to soil pore water, and is calculated as follows:

$$P_{HTOsoil_plant} = \frac{P_{air_plant} \cdot \rho_b}{P_{air_spw} \cdot 1000 \cdot \theta}$$

where,

P_{air_plant} = transfer from air to plant ($m^3/kg\text{-fw}$) (49.5 $m^3/kg\text{-fw}$ from Table A.5f CSA, 2014)

P_{air_spw} = transfer from air to soil pore water (m^3/L) (43.5 m^3/L from Table A.4g CSA, 2014)

θ = volumetric moisture content of soil (m^3 water/ m^3 soil) (0.3 from Clause 6.3.4.3 CSA, 2014)

ρ_b = bulk density of the soil (kg/m^3) (1400 kg/m^3 for clay from CSA, 2014)

The tritium BAF for terrestrial invertebrates was obtained from Beresford (2008). All tritium BAFs, which are derived from a specific activity model, are summarized in Table 4.23.

For tritium, the majority of the tritium taken into the animal is from water ingestion and food consumption. Soil ingestion dose from tritium is negligible. The transfer of tritium to animals ($P_{HTOwater_animal}$, L/kg-fw) through water ingestion was determined using the specific activity model from CSA N288.1 (2014), and is calculated as follows:

$$P_{\text{HTOwater_animal}} = k_{\text{aw}} \cdot f_{\text{w-w}} \cdot (1 - \text{DW}_a)$$

where,

- k_{aw} = fraction of water from contaminated sources (assumed to be 1)
 $f_{\text{w-w}}$ = fraction of the animal water intake derived from direct ingestion of water (0.5 from CSA N288.1-14)
 DW_a = dry/fresh weight ratio for animal products (kg-dw/kg-fw) (0.3 from CSA N288.1-14)

The transfer of tritium to animals through food ingestion ($P_{\text{HTOfood_animal}}$, unitless) was also determined using the specific activity model from CSA N288.1 (2014), and is calculated as follows:

$$P_{\text{HTOfood_animal}} = k_{\text{af}} \cdot ((1 - f_{\text{OBT}}) \cdot f_{\text{w-pw}} + 0.5 \cdot f_{\text{w-dw}}) \cdot (1 - \text{DW}_a) / (1 - \text{DW}_p)$$

where,

- k_{af} = fraction of food from contaminated sources (assumed to be 1)
 $f_{\text{w-pw}}$ = fraction of the animal water intake derived from water in the plant feed
 $f_{\text{w-dw}}$ = fraction of the animal water intake that results from the metabolic decomposition of the organic matter in the feed
 f_{OBT} = fraction of total tritium in the animal product in the form of OBT as a result of HTO ingestion
 $1 - \text{DW}_a$ = water content of the animal product (L water/kg-fw)
 $1 - \text{DW}_p$ = water content of the plant/food (L water/kg-fw plant)

For each receptor, the water content of the total diet (DW_p) was determined based on the weighted average of the water content of the individual food items in the receptor's diet. For example, the red fox's diet consists of 50% small mammals, 30% waterfowl and 20% vegetation. The combined DW_p for the red fox was the weighted average of the dry weight fraction for small mammals, waterfowl, and vegetation.

A summary of the input parameters is provided in Table 4.24 and a summary of the transfer factors for tritium are provided in Table 4.26.

Table 4.23: Summary of BAFs for Tritium and Carbon-14

Receptor	Units	Tritium	Carbon-14	References
Fish	L/kg fw	7.50E-01	5.70E+03	As discussed in text
Aquatic Plant	L/kg fw	7.50E-01	5.90E+03	As discussed in text
Benthic Invertebrate	L/kg fw	7.50E-01	5.20E+03	As discussed in text
Amphibian	L/kg fw	7.50E-01	5.70E+03	As discussed in text
Terrestrial Plant	kg-dw/kg-fw	5.31E+00	-	As discussed in text
Terrestrial Invertebrate	kg-dw/kg-fw	1.50E+02	-	Beresford (2008)

4.2.3.4.7 Specific Activity Model for Carbon-14

Aquatic BAFs for carbon-14 assume that the carbon-14 to stable carbon ratio in aquatic animals is equal to the ratio in dissolved inorganic carbon in the water. Therefore the BAF (L/kg-fw) for aquatic animals, invertebrates, and plants is calculated as follows:

$$BAF_{C14} = S_a/S_w$$

where,

S_a = stable carbon content in the aquatic animal/invertebrate/plant (gC/kg-fw)
 S_w = mass of stable carbon in the dissolved inorganic phase in water (gC/L)

S_w is 0.0213 gC/L, consistent with CSA N288.1 (2014). For fish the stable carbon content is 122 gC/kg-fw, for freshwater invertebrates the stable carbon content for marine crustaceans (111 gC/kg-fw) was considered appropriate, and for aquatic plants the stable carbon content for terrestrial plants (500 gC/kg-dw or 125 gC/kg-fw) was considered appropriate (CSA N288.1, 2014).

The transfer of carbon-14 from soil to plant or invertebrate is based on the assumption that the specific activity of carbon-14 ($Bq^{14}C/g-C$) is the same in the plant or soil invertebrate as that measured in soil. That specific activity was multiplied by the stable carbon concentration in the plant or soil invertebrate to obtain the carbon-14 concentration in the plant or soil invertebrate at the soil sampling location. Thus,

$$\frac{Bq^{14}C_{plant}}{kg-C_{plant}} \times \frac{kg-C_{plant}}{kg(dw)_{plant}} = \frac{Bq^{14}C}{kg(dw)_{plant}}$$

For carbon-14, food consumption contributes to the majority of the carbon ingested by the animal, compared to inhalation, water and soil ingestion. The transfer of carbon-14 from food to animals was determined using a specific activity model consistent with that presented in CSA N288.1 2014 update.

$$P_{C14\text{food_animal}} = k_{af} \cdot S_a / S_p$$

where,

- S_a = stable carbon content in the animal (gC/kg-fw) (X_{5_C} in N288.1-14)
 S_p = stable carbon content in the food (gC/kg-fw) ($X_{4_C} \cdot DW_p$ in N288.1-14)

The stable carbon content in the animal was obtained from CSA N288.1 (2014). The beef value was applied for all mammals and the poultry value was applied for all birds. For each receptor, the carbon content of the total diet (S_p) was determined based on the weighted average of the carbon content of the individual food items in the receptor's diet. A summary of the input parameters is provided in Table 4.24 and Table 4.25, and a summary of the transfer factor for carbon-14 is provided in Table 4.26.

Table 4.24: Input Parameters for Specific Activity Calculations for Tritium and Carbon-14

Receptor	f_{w_ww}	f_{w_pw}	f_{w_dw}	f_{OBT}	DW_p (kg-dw/kg-fw)	S_a (gC/kg-fw)	S_p (gC/kg-fw)
Trumpeter Swan	0.22	0.65	0.121	0.1	0.25	244	125
Ring-billed Gull	0.22	0.65	0.121	0.1	0.26	244	129.3
Common Tern	0.22	0.65	0.121	0.1	0.25	244	120.9
Bufflehead	0.22	0.65	0.121	0.1	0.25	244	112.4
Muskrat	0.413	0.509	0.071	0.11	0.25	201	124.4
Red-winged Blackbird	0.22	0.65	0.121	0.1	0.3	244	111
Red-tailed Hawk	0.22	0.65	0.121	0.1	0.3	244	210.8
Red fox	0.413	0.509	0.071	0.11	0.278	201	191
Meadow vole	0.413	0.509	0.071	0.11	0.19	201	95

Notes:

f_{w_w} , f_{w_pw} , f_{w_dw} , and f_{OBT} are from Table 16 and 17 in CSA N288.1 (2014).
 S_a are the beef and poultry values from Table 18 in CSA N288.1 (2014)

Table 4.25: Stable Carbon Content for Food Types

Food Type	Stable Carbon Content (gC/kg-fw)	Reference
aquatic plants	125	CSA 2014
fish	122	CSA 2014
insects/earthworms	111	CSA 2014
small mammals	200	IAEA 2010 (Table 67)
benthic invertebrates	111	CSA 2014
birds	240	IAEA 2010 (Table 67)
vegetation	95	Zach and Sheppard 1992 (adjusted to fw)

Table 4.26: Summary of Transfer Factors for Tritium and Carbon-14

Receptor	P_{HTOwater_animal} (L/kg-fw)	P_{HTOfood_animal} (unitless)	P_{C14food_animal} (unitless)
Trumpeter Swan	0.154	0.60	1.95
Ring-billed Gull	0.154	0.61	1.89
Common Tern	0.154	0.60	2.02
Bufflehead	0.154	0.60	2.17
Muskrat	0.289	0.46	1.61
Red-winged Blackbird	0.154	0.65	2.20
Red-tailed Hawk	0.154	0.65	1.16
Red fox	0.289	0.47	1.05
Meadow vole	0.289	0.42	2.12

4.2.4 Dispersion Models

AERMOD was used by OPG (2015e) to estimate the hydrazine concentration in air at the PN site boundary. Results from AERMOD are reported in this risk assessment.

The MOECC approved model in the Appendix to O.Reg.346/90 was used to estimate maximum ½ hour concentrations of COPCs at the PN site boundary to support the ESDM (OPG, 2015e). Results are reported in this risk assessment. Uncertainties in the model are discussed in Section 3.2.7.

4.2.5 Exposure Point Concentrations and Doses

4.2.5.1 Exposure Point Concentrations

The concentration and doses used for the exposure evaluation are listed in Table 4.27. The exposure values are based on monitoring and measurements at the PN site. There are media-specific concentrations used for the various receptors and receptor locations.

Information from 2011 to 2015 on the radiological contaminants discharged in liquid effluents into the environment was available from 2011 to 2015 monthly liquid effluent releases to the CCW and monthly CCW flow data. The contaminants are reported as tritium, carbon-14 and gross beta/gamma. The gross beta/gamma radionuclide with the most restrictive DRL for aquatic biota, cobalt-60, was chosen to represent the gross beta/gamma emissions in the risk calculations (see Appendix C). The aquatic biota at the outfall is assumed to be exposed to radionuclide concentrations equal to the effluent discharge concentration. Although lake surface water data were available for radionuclides from the 2015 baseline environmental monitoring program, results were generally below detection limits. Emissions data from the EMP provided measured concentrations at lower detection limits; therefore EMP emissions data were used as exposure point concentrations in the EcoRA.

As part of the baseline environmental monitoring program, water and sediment data were collected from the north and south ends of Frenchman's Bay, as discussed in Section 4.1.3.2.3. The concentrations observed at Frenchman's Bay reflect the contribution from PN in addition to urban runoff into the wetland. A surface water model has been developed for PN to support Pickering Safe Storage Project activities (Golder and EcoMetrix, 2017). The surface water model is based on current and temperature data from 2011 and 2012, and is used to predict water concentrations at the inlet to Frenchman's Bay and Ajax WTP based on a tracer concentration for any parameter of 1 mg/L (Golder and EcoMetrix, 2017). A mass-balance model has also been used to predict concentrations in Frenchman's Bay, assuming a completely mixed embayment, with inputs from lake exchange and tributaries. Based on the surface water model and mass balance model, the dilution factors for PN U1-4 and U5-8 releases at the inlet to Frenchman's Bay and inside the bay are approximately 7 and 9 respectively.

The assessment at Frenchman's Bay presented in the EcoRA focuses on parameters identified as COPCs in lake water samples and Frenchman's Bay water samples. The COPCs include: hydrazine, morpholine, copper, aluminum, sodium, iron, total residual chlorine, tritium, carbon-14, cobalt-60, cesium-134, and cesium-137. A longer list of COPCs was identified in Frenchman's Bay sediment samples; however, many of those COPCs are not facility related and the contributions from PN to the sediment concentrations at Frenchman's Bay are small. A comparison between the exposure/risk results from observed water and sediment concentrations at Frenchman's Bay, and PN contributions only, is provided in Appendix E for all parameters exceeding screening levels.

In instances where there were non-detects in the dataset and they were not predominant (<15%), they were replaced with a one-half MDL value, and a mean value was determined. However, when more than 50% of the dataset was comprised of non-detects, there is no method to provide a reliable estimate of the mean (CSA, 2012). To be conservative, in these instances the detection limit was considered to be a measured value and was used in the dataset to calculate the mean, likely overestimating the concentrations found at the location.

Table 4.27: Exposure Values for the PN Exposure Assessment

Location	Media	VEC Category	COPC	Units	Maximum Concentration	Mean Concentration	Notes
Radionuclides							
Outfall	Water	Fish Aquatic invertebrates Riparian bird	Tritium Carbon-14 Gross β/γ represented by Cobalt-60	Bq/L	1.70E+02 1.97E-02 7.18E-02	7.38E+01 1.24E-03 6.57E-03	Max and mean values based on monthly effluent and CCW flow rates from PN U1-4 and PN U5-8 from 2011 to 2015.
	Sediment	Fish Aquatic invertebrates Riparian bird	Carbon-14 Gross β/γ represented by Cobalt-60	Bq/kg dw	1.14E+03 < 5.00E-01	3.67E+02 < 2.88E-01	Max and mean of PN U5-8 Discharge 2006-2009 EMP reports
	Air	Riparian bird	Noble gases (Argon-41)	$\mu\text{Gy/d}$	1.30E-02	5.35E-03	Air Kerma Rates 2011-2015 EMP for Argon-41 for PN site locations (P2, P3, P4, P6, P7, P10, P11)

Location	Media	VEC Category	COPC	Units	Maximum Concentration	Mean Concentration	Notes
Frenchman's Bay	Water	Fish Aquatic invertebrate Riparian birds Amphibians Riparian mammals Aquatic plants	Tritium Carbon-14 Cobalt-60, Cesium-134, Cesium-137	Bq/L	1.62E+01 4.48E-01 <1.00E-01	1.34E+01 1.95E-01 <1.00E-01	2015 Frenchman's Bay Sampling Carbon-14 (sediment concentration/ K_d)
	Sediment	Fish Aquatic invertebrate Riparian birds Amphibians Riparian mammals Aquatic plants	Carbon-14 Cobalt-60 Cesium-134 Cesium-137	Bq/kg	2.24E+01 <1.00E+00 <3.30E+00 3.16E+00	9.73E+00 <1.00E+00 <3.30E+00 2.00E+00	2015 Frenchman's Bay Sampling
	Air	Riparian birds Riparian mammals	Noble gases (Argon-41)	μ Gy/d	2.27E-03	1.90E-03	Air Kerma Rates 2011-2015 EMP for Argon-41 for Frenchman's Bay (P8)

Location	Media	VEC Category	COPC	Units	Maximum Concentration	Mean Concentration	Notes
PN site	Water	Terrestrial plants Terrestrial birds Terrestrial mammals	Tritium Carbon-14 Cobalt-60	Bq/L	1.70E+02 1.97E-02 7.18E-02	7.38E+01 1.24E-03 6.57E-03	Concentrations are those from the outfall
	Soil	Terrestrial plants Terrestrial invertebrates Terrestrial birds Terrestrial mammals	Tritium Cobalt-60 Cesium-134 Cesium-137 Carbon-14	Bq/kg dw Bq/kg dw Bq/kg dw Bq/kg dw Bq/kg-C	9.24E+01 <1.00E+00 <1.00E+00 <1.00E+00 5.57E+02	3.16E+01 <1.00E+00 <1.00E+00 <1.00E+00 1.89E+02	2015 Site Soil Sampling
	Air	Terrestrial plants Terrestrial invertebrates Terrestrial birds Terrestrial mammals	Noble gases (Argon-41)	µGy/d	1.30E-02	5.35E-03	Air Kerma Rates 2011-2015 EMP for Argon-41 for on-site locations (P2, P3, P4, P6, P7, P10, P11)
	Air	Terrestrial birds	Noble gases	Bq•MeV/m ³	3.55E+01	1.62E+01	Estimated air concentration at U7/U8 based on IMPACT model using max and mean of 2011-2015 noble gas emissions data

Location	Media	VEC Category	COPC	Units	Maximum Concentration	Mean Concentration	Notes
Non-Radionuclides							
Outfall	Water	Fish Aquatic invertebrates Riparian bird	Hydrazine Morpholine Copper Total residual chlorine	mg/L	2.50E-04 6.00E-03 8.80E-03 1.20E-03	8.79E-05 < 4.10E-03 < 1.75E-03 < 1.20E-03	2015 Lake Water Sampling Program for max and mean copper, morpholine, , and total residual chlorine (LW-10, LW-21, LW-9, LWE-1 in Figure 3.2) Max and mean hydrazine from EcoMetrix (2015) (Figure 3.3, near outfall)
	Sediment	Fish Aquatic invertebrates Riparian bird	Hydrazine Morpholine Copper Total residual chlorine	mg/kg fw	0.00E+00 0.00E+00 2.21E+01 0.00E+00	0.00E+00 0.00E+00 4.40E+00 0.00E+00	Estimated using water:sediment partitioning (see Section 4.2.2.2)

Location	Media	VEC Category	COPC	Units	Maximum Concentration	Mean Concentration	Notes
Frenchman's Bay	Water	Aquatic invertebrate	Hydrazine	mg/L	2.91E-05	1.02E-05	2015 Frenchman's Bay Sampling Max and mean hydrazine from EcoMetrix (2015) near outfall with dilution factor = 9
			Morpholine		<4.00E-03	<4.00E-03	
		Riparian birds	Copper		2.10E-03	1.69E-03	
		Amphibians	Aluminum		2.70E-01	1.40E-01	
		Riparian mammals	Sodium		9.10E+01	5.70E+01	
			Iron		5.60E-01	2.84E-01	
		Aquatic plants	Total residual chlorine		<1.20E-03	<1.20E-03	
	Sediment	Aquatic invertebrate	Hydrazine	mg/kg dw	0.00E+00	0.00E+00	2015 Frenchman's Bay Sampling For hydrazine morpholine, and total residual chlorine estimated using water:sediment partitioning (see Section 4.2.2.2)
			Morpholine		0.00E+00	0.00E+00	
		Riparian birds	Copper		7.40E+01	4.53E+01	
		Amphibians	Aluminum		1.30E+04	8.86E+03	
		Riparian mammals	Sodium		5.90E+02	3.80E+02	
			Iron		2.10E+04	1.61E+04	
		Aquatic plants	Total residual chlorine		0.00E+00	0.00E+00	

Location	Media	VEC Category	COPC	Units	Maximum Concentration	Mean Concentration	Notes
PN site	Water	Terrestrial plants Terrestrial birds Terrestrial mammals	Arsenic Copper Lead Zinc Cyanide Petroleum hydrocarbon F4	mg/L	<1.10E-03 8.80E-03 <5.00E-04 6.20E-03 - <2.00E-01	<1.00E-03 <1.75E-03 <5.00E-04 <5.03E-03 - <2.00E-01	2015 Lake Water Sampling
	Soil	Terrestrial plants Terrestrial invertebrates Terrestrial birds Terrestrial mammals	Arsenic Copper Lead Zinc Cyanide Petroleum hydrocarbon F4	mg/kg dw	5.80E+01 8.30E+02 2.30E+02 3.20E+03 3.30E-01 5.70E+03	5.46E+00 6.83E+01 2.57E+01 2.87E+02 1.08E-01 1.63E+03	2015 Soil Sampling

4.2.5.2 Exposure Doses

The exposure concentrations in Section 4.2.5.1 (based on data from 2011 to 2015), along with the exposure factors in Section 4.2.3.4, were applied to the equations in Section 4.2.3 to estimate the radiological dose to all biota and non-radiological dose to birds and mammals. The estimated doses are presented in Table 4.28 to Table 4.32. The breakdown of radiological dose to each receptor is shown graphically in Figure 4.10 to Figure 4.12.

Table 4.28: Estimated Radiation Dose for Aquatic Biota at the Outfall (mGy/d)

COPC		Pelagic Fish	Bottom Dwelling Fish	Benthic Invertebrate	Ring-Billed Gull
Tritium	max	1.76E-05	1.76E-05	1.76E-05	1.29E-04
	mean	7.65E-06	7.65E-06	7.67E-06	4.53E-05
Carbon-14	max	7.64E-05	7.65E-05	8.99E-05	7.65E-04
	mean	4.82E-06	4.86E-06	1.11E-05	3.00E-04
Cobalt-60	max	2.20E-05	2.50E-05	2.55E-05	4.78E-05
	mean	2.01E-06	4.04E-06	9.90E-06	4.05E-05
Argon-41	max	-	-	-	1.30E-05
	mean	-	-	-	5.35E-06
Total Dose	max	1.16E-04	1.19E-04	1.33E-04	9.55E-04
	mean	1.45E-05	1.65E-05	2.86E-05	3.91E-04

Table 4.29: Estimated Radiation Dose for Aquatic Biota at Frenchman's Bay (mGy/d)

COPC		Pelagic Fish	Bottom Dwelling Fish	Frog/Turtle	Benthic Invertebrate	Aquatic Plant	Muskrat	Trumpeter Swan	Bufflehead	Common Tern	Ring-Billed Gull
Tritium	max	1.68E-06	1.68E-06	1.68E-06	1.68E-06	1.68E-06	1.41E-06	1.36E-06	1.36E-06	1.36E-06	1.20E-04
	mean	1.39E-06	1.39E-06	1.39E-06	1.39E-06	1.39E-06	1.17E-06	1.12E-06	1.12E-06	1.12E-06	4.17E-05
Carbon-14	max	1.74E-03	1.74E-03	1.74E-03	1.57E-03	1.71E-03	2.89E-03	3.51E-03	3.49E-03	3.47E-03	2.64E-03
	mean	7.54E-04	7.54E-04	7.54E-04	6.80E-04	7.44E-04	1.26E-03	1.52E-03	1.51E-03	1.51E-03	1.15E-03
Cobalt-60	max	3.06E-05	3.37E-05	1.49E-05	3.05E-05	1.02E-04	1.16E-05	1.73E-04	5.63E-05	2.02E-05	5.04E-05
	mean	3.06E-05	3.37E-05	1.49E-05	3.05E-05	1.02E-04	1.16E-05	1.73E-04	5.63E-05	2.02E-05	5.04E-05
Cesium-134	max	1.72E-03	1.72E-03	8.16E-04	5.35E-05	3.88E-05	1.04E-04	1.28E-04	9.14E-05	2.18E-03	1.35E-03
	mean	1.72E-03	1.72E-03	8.16E-04	5.35E-05	3.88E-05	1.04E-04	1.28E-04	9.14E-05	2.18E-03	1.35E-03
Cesium-137	max	1.54E-03	1.54E-03	1.12E-03	3.73E-05	5.26E-05	8.51E-05	1.06E-04	7.43E-05	1.85E-03	1.14E-03
	mean	1.54E-03	1.54E-03	1.12E-03	3.22E-05	5.26E-05	8.43E-05	1.05E-04	7.33E-05	1.85E-03	1.14E-03
Argon-41	max	-	-	-	-	-	2.27E-06	2.27E-06	2.27E-06	2.27E-06	2.27E-06
	mean	-	-	-	-	-	1.90E-06	1.90E-06	1.90E-06	1.90E-06	1.90E-06
Total Dose	max	5.03E-03	5.04E-03	3.69E-03	1.69E-03	1.91E-03	3.09E-03	3.92E-03	3.71E-03	7.53E-03	5.31E-03
	mean	4.04E-03	4.06E-03	2.71E-03	7.98E-04	9.39E-04	1.46E-03	1.93E-03	1.74E-03	5.56E-03	3.73E-03

Note:

Max and mean dose for Cobalt-60, Cesium-134, and Cesium-137 are generally equivalent for most receptors since surface water and sediment concentrations were generally measured below the detection limit.

Table 4.30: Estimated Radiation Doses for Terrestrial Biota at the PN Site (mGy/d)

COPC		Earthworm	Terrestrial Plant	Meadow Vole	Red-Winged Blackbird	Red Fox	Red-Tailed Hawk
Tritium	max	1.92E-03	6.80E-05	3.58E-05	1.24E-03	2.19E-05	2.37E-04
	mean	6.55E-04	2.33E-05	1.29E-05	4.24E-04	8.37E-06	8.15E-05
Carbon-14	max	4.20E-05	3.56E-05	7.61E-05	9.24E-05	1.14E-03	9.32E-05
	mean	1.43E-05	1.21E-05	2.58E-05	3.14E-05	4.92E-04	3.16E-05
Cobalt-60	max	3.11E-05	1.08E-05	1.20E-05	1.12E-05	1.55E-05	1.11E-05
	mean	3.11E-05	1.08E-05	1.20E-05	1.11E-05	1.55E-05	1.10E-05
Cesium-134	max	2.00E-05	2.47E-06	7.42E-06	7.14E-06	1.50E-05	7.10E-06
	mean	2.00E-05	2.47E-06	7.42E-06	7.14E-06	1.50E-05	7.10E-06
Cesium-137	max	7.33E-06	2.67E-06	2.72E-06	2.77E-06	2.10E-05	2.69E-06
	mean	7.33E-06	2.67E-06	2.72E-06	2.77E-06	2.1076E-05	2.69E-06
Argon-41	max	-	1.30E-05	1.30E-05	1.30E-05	1.30E-05	1.30E-05
	mean	-	5.35E-06	5.35E-06	5.35E-06	5.35E-06	5.35E-06
Total Dose	max	2.02E-03	1.20E-04	1.34E-04	1.35E-03	1.22E-03	3.51E-04
	mean	7.28E-04	5.13E-05	6.08E-05	4.77E-04	5.51E-04	1.34E-04

Note:

Max and mean dose for Cobalt-60, Cesium-134, and Cesium-137 are generally equivalent for most receptors since soil concentrations were generally measured below the detection limit.

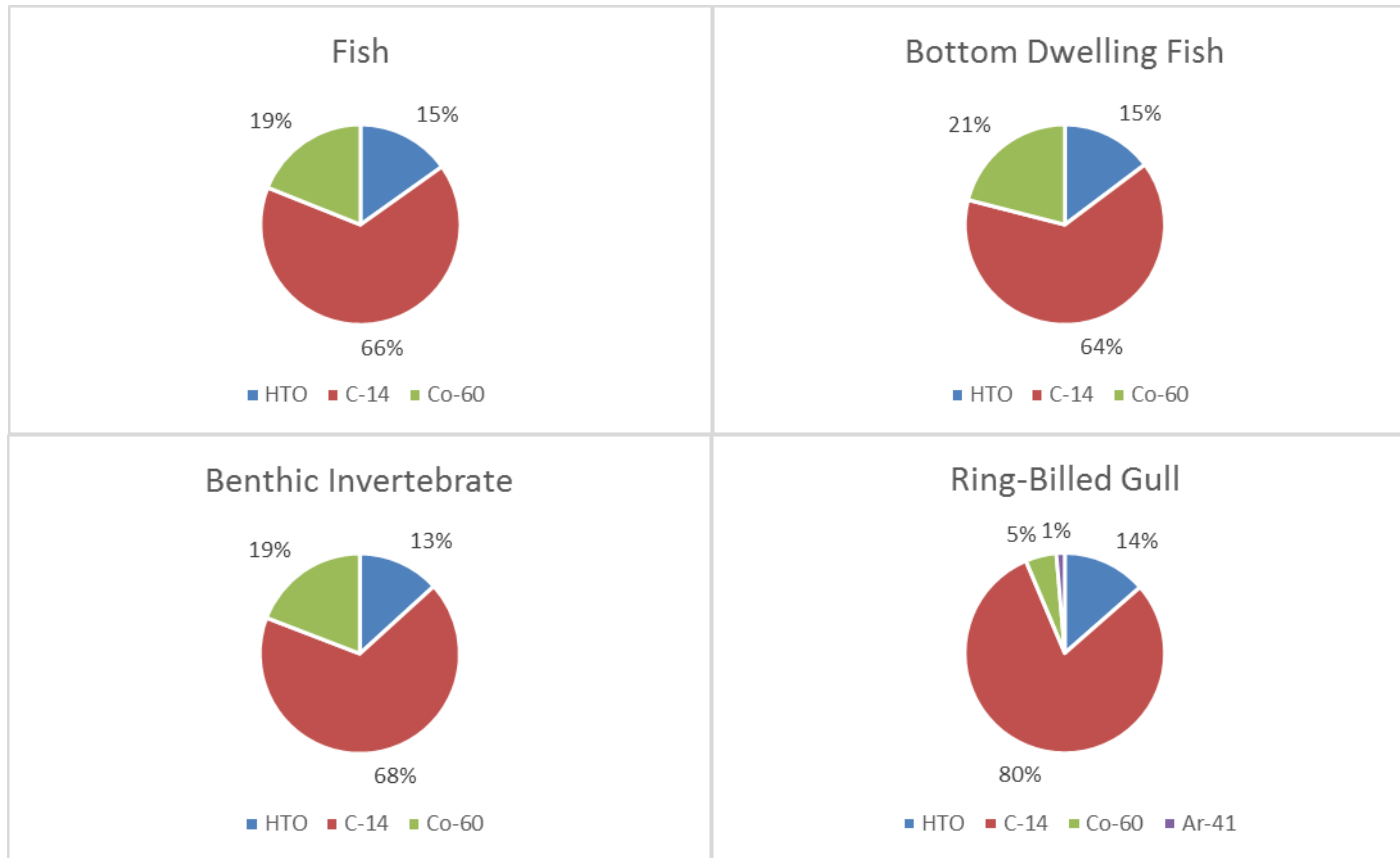

Figure 4.10: Radiological Dose Breakdown for Receptors at the Outfall

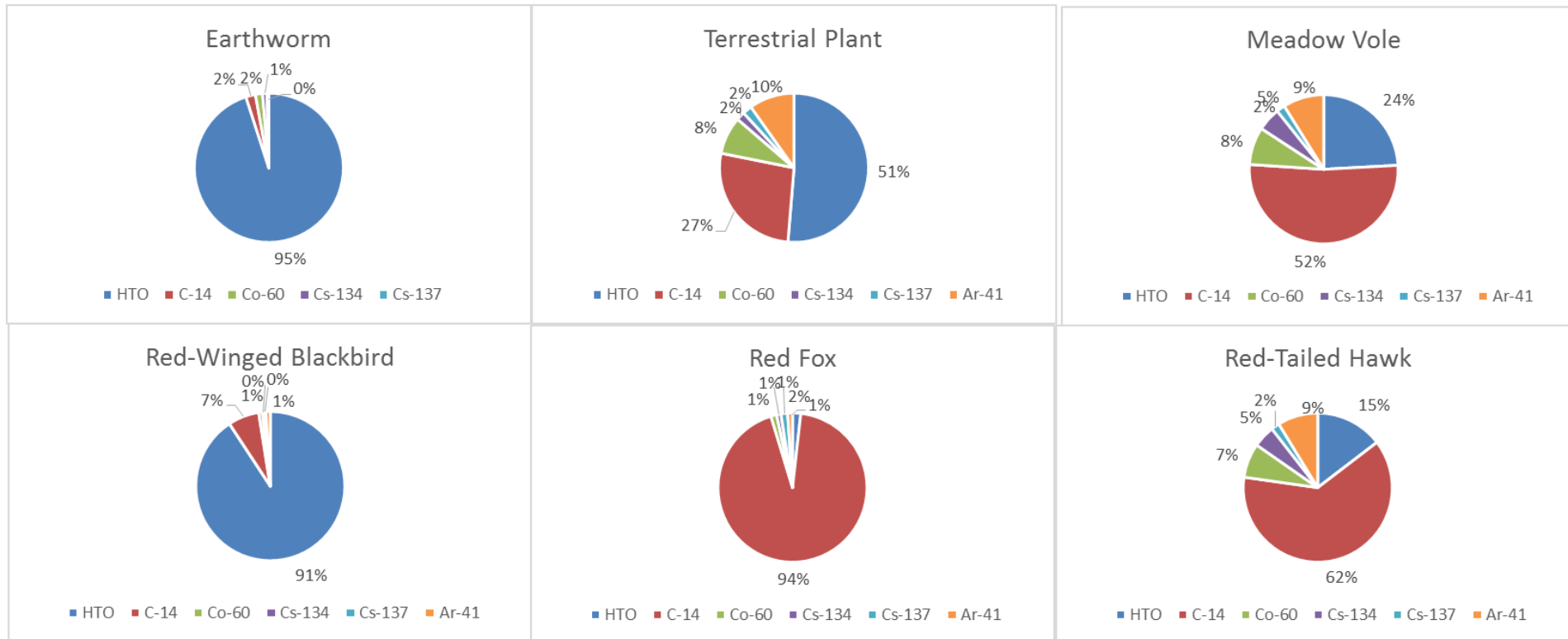

Figure 4.11: Radiological Dose Breakdown for Receptors at the PN Site

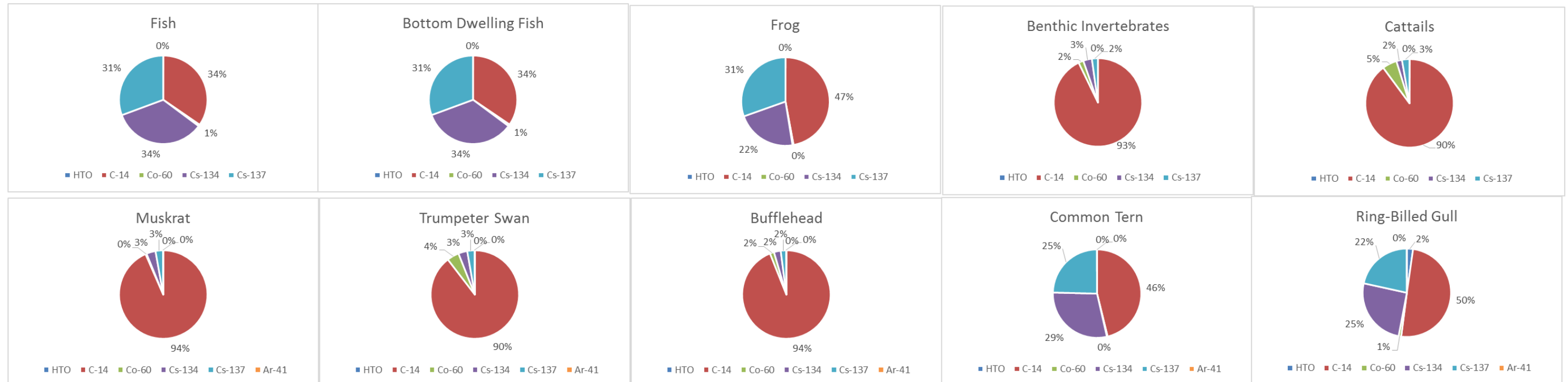

Figure 4.12: Radiological Dose Breakdown for Receptors at Frenchman's Bay

Table 4.31: Estimated Non-Radiological Dose for Riparian Birds and Mammals at PN Outfall and Frenchman's Bay (mg/kg·d)

COPC		PN Outfall	Frenchman's Bay ²				
		Ring-Billed Gull	Muskrat	Trumpeter Swan	Bufflehead	Common Tern	Ring-Billed Gull
Hydrazine	max	1.51E-04 ¹	2.83E-06 ¹	7.78E-07 ¹	2.20E-06 ¹	1.14E-05 ¹	1.76E-05 ¹
	mean	5.33E-05 ¹	9.97E-07 ¹	2.74E-07 ¹	7.73E-07 ¹	4.02E-06 ¹	6.20E-06 ¹
Morpholine	max	3.64E-03 ¹	3.90E-04 ¹	1.07E-04 ¹	3.02E-04 ¹	1.57E-03 ¹	2.42E-03 ¹
	mean	2.48E-03 ¹	3.90E-04 ¹	1.07E-04 ¹	3.02E-04 ¹	1.57E-03 ¹	2.42E-03 ¹
Copper	max	3.94E+00	2.07E+00	8.71E-01	9.97E-01	1.13E-01	3.75E+00
	mean	6.37E-01	1.63E+00	6.85E-01	6.62E-01	8.19E-02	7.29E-01
Chlorine (TRC)	max	2.84E-02	1.81E-02	7.59E-03	6.78E-02	1.55E-02	2.84E-02
	mean	2.84E-02	1.81E-02	7.59E-03	6.78E-02	1.55E-02	2.84E-02
Aluminum	max	N/A	9.97E+01	4.19E+01	4.49E+02	2.20E+01	6.86E+01
	mean	N/A	5.70E+01	2.40E+01	2.54E+02	1.28E+01	4.06E+01
Sodium	max	N/A	5.02E+02	2.09E+02	3.01E+02	9.91E+01	2.69E+02
	mean	N/A	3.14E+02	1.31E+02	1.89E+02	6.21E+01	1.69E+02
Iron	max	N/A	5.73E+02	2.41E+02	8.06E+02	4.87E+01	2.32E+02
	mean	N/A	3.04E+02	1.28E+02	4.63E+02	2.81E+01	1.31E+02

Note:

¹ Doses calculated only account for ingestion of water, sediment and fish/frog ingestion (as applicable) due to the lack of information on tissue concentrations of hydrazine and morpholine in other foods.

² Max and mean dose for morpholine and TRC are generally equivalent for most receptors since surface water concentrations were generally measured below the detection limit.

Table 4.32: Estimated Non-Radiological Dose for Terrestrial Birds and Mammals at the PN Site (mg/kg·d)

COPC		Meadow Vole	Red-winged Blackbird	Red Fox	Red-Tailed Hawk
Arsenic	max	9.87E-01	2.06E+00	1.24E-01	3.43E+00
	mean	9.31E-02	1.94E-01	2.78E-02	3.23E-01
Copper	max	4.24E+01	7.22E+01	2.72E+00	4.66E+01
	mean	3.49E+00	5.94E+00	2.25E-01	3.84E+00
Lead	max	6.86E-01	1.40E+01	1.40E-01	1.29E+01
	mean	7.69E-02	1.57E+00	1.62E-02	1.45E+00
Zinc	max	2.62E+02	1.31E+03	8.78E+01	2.01E+02
	mean	2.35E+01	1.18E+02	7.88E+00	1.80E+01
Cyanide	max	5.16E-04	3.87E-03	1.78E-04	1.82E-02
	mean	1.68E-04	1.26E-03	5.83E-05	5.95E-03
Petroleum Hydrocarbon F4	max	8.93E+00	6.69E+01	3.10E+00	3.15E+02
	mean	2.58E+00	1.92E+01	8.99E-01	9.01E+01

4.2.5.2.1 Pickering Waste Management Facility

The dose rate for ecological receptors in close proximity to the PWMF (approximately 5 m from any wall) could be up to 0.5 $\mu\text{Gy/h}$ (0.012 mGy/d), assuming full capacity of the PWMF, as shown in Section 4.1.3.5.1.

The dose rate to any ecological VEC at the closest PN property boundary would be much lower than 0.5 $\mu\text{Gy/h}$ (0.012 mGy/d).

The above assessment is conservative as it assumes the receptor is always located at the PWMF and does not incorporate an occupancy factor based on the fraction of time a receptor is likely to be in close proximity to the PWMF.

4.2.6 Uncertainties in the Exposure Assessment

Uncertainties in the exposure assessment include the representativeness of media concentrations used in the assessment at each location. Mean concentrations of COPCs were used for each location and media, where possible, and are considered to be representative for all mobile receptors. Maximum concentrations found in various sources were also used as an upper bound on exposure. These values are, by definition, not representative for mobile organisms that can move around the site, effectively averaging their exposure concentrations. In addition, migratory birds were assumed to reside in the area 100% of the time, which further increases their exposure concentrations. Maximum values are representative for exposures of any sessile organisms that reside at the location of the maximum value.

Although the majority of data comes from measured values, partition coefficients were used to estimate COPC concentrations in media that were not measured (i.e., water concentration for carbon-14 was estimated from a sediment concentration). Uncertainties in organism exposure arise from these estimated concentrations and from the use of BAFs to calculate uptake into tissues. In some cases, BAFs for a species of interest were unavailable, and surrogate values were used, e.g., fish values used for frog. The partition coefficients and BAFs used for the exposure assessment were not site-specific, and were taken from reputable sources and are considered to be representative of the conditions found at the site. This is a best estimate.

Wildlife exposure factors, such as intake rates and diets, are a potential source of uncertainty. Reputable sources are used for these factors and are considered to be representative of the organisms assessed.

Dose coefficients were obtained from reputable sources for reference organisms, but have not been derived specifically for all the organisms assessed. Dose coefficients for surrogate organisms were often used. They were selected with attention to similar body size and exposure habits, and are believed to adequately represent the organism

assessed. Dose coefficients for each receptor were not adjusted for body size and dimensions.

Radiation doses were calculated from measured concentrations of radionuclides such as cobalt-60, cesium-134, and cesium-137 in water. The majority of samples resulted in concentrations below the detection limit. Doses were calculated assuming these concentrations were at the detection limit. This is likely a conservative assumption and doses resulting from these radionuclides are likely lower than presented.

Average dilution factors from the surface water model were used to estimate concentrations at Frenchman’s Bay to determine the PN station contribution to exposure at Frenchman’s Bay. Based on maximum and minimum lake water conditions, on an hourly basis, the dilution factors from PN to inside Frenchman’s Bay can range from 4 to 24, with an average dilution factor of 9. The average value is considered to be realistic for chronic exposure estimates.

The main uncertainties and assumptions associated with the exposure assessment are summarized in Table 4.33.

Table 4.33: Summary of Major Uncertainties in the Ecological Exposure Assessment

Risk Assessment Assumption	Justification	Over/Under Estimate Risk?
Average dilution factors from the surface water model were used to estimate water concentrations at Frenchman’s Bay to determine station contribution	Based on maximum and minimum lake water conditions the dilution factors from PN to Frenchman’s Bay can range from 4 to 24, with an average dilution factor of 9.	Neither (value is a best estimate)
Kds, BAFs, intake rates, etc. are from literature when measured information as not available	Reputable literature sources were used	Neither (value is best estimate)
BAF (fish) for hydrazine is based on QSAR model and not measured bioaccumulation data.	Limited information exists on bioaccumulation of hydrazine, although it is expected to be low. Only one study (Slonim and Gisclard, 1976) exists on hydrazine bioaccumulation, and there is large uncertainty surrounding the methods and results.	Neither (value is best estimate)

Risk Assessment Assumption	Justification	Over/Under Estimate Risk?
BAF (fish) for morpholine is based on QSAR model and not measured bioaccumulation data.	No information in literature regarding morpholine BAF, although it is not expected to bioaccumulate.	Neither (value is best estimate)
Dose coefficients for each receptor were not adjusted for exact VEC body size and dimensions	Surrogates selected with attention to similar body size and exposure habits.	Neither (value is best estimate)

4.3 Effects Assessment

The potential for ecological effects from COPC exposure at each location (Section 4.2) was assessed by comparing the exposure levels to toxicological, radiation, and thermal benchmarks. These benchmarks values (BVs) are taken from literature and are compared to the exposure values (EVs) to determine the potential for adverse ecological effects.

4.3.1 Toxicological Benchmarks

For hydrazine, the aquatic toxicity benchmark values were taken from the Federal Environmental Quality Guidelines (EC, 2013). Morpholine aquatic toxicity benchmark values were taken from WHO (1996). Since the benchmarks listed by EC for hydrazine (for fish and benthic invertebrates) and those listed by WHO for morpholine are acute, they were converted to chronic benchmarks by dividing by a factor of 10 (CCME, 1999a; Suter *et al.*, 1993). Chronic benchmarks are appropriate for hydrazine and morpholine, as exposure is based on a continuous release.

All aquatic benchmarks are summarized in Table 4.35, and were generally LCVs obtained from Suter and Tsao (1996). The toxicity benchmarks for copper for aquatic plants and iron for benthic invertebrates were the CCME water quality benchmarks instead of the LCVs from Suter and Tsao (1996), since the LCVs were lower than the CCME water quality benchmark. For assessment of benthic invertebrates toxicity benchmarks have been presented as water concentrations. Benthic invertebrates may reside on the sediment surface where they are exposed to contaminant concentrations in the water column or they reside in the sediment. The latter frequently pump water through their burrows exposing them to aqueous contaminants. In addition, sediment toxicity benchmarks, (MOECC LELs) were also used to assess to assess toxicity to benthic invertebrates (Table 4.36).

Sodium was considered to be essentially non-toxic for birds and mammals, as noted by Health Canada (1992) for people. It is effectively regulated in the body and has not been associated with adverse effects in birds and mammals at environmental concentrations.

The screening benchmark for sulphate (100 mg/L) is the British Columbia Ministry of the Environment (BC MOE) short-term maximum water quality guideline from 2000 for the protection of freshwater aquatic life. At that time not enough toxicity data existed to propose a long-term 30 day average guideline. The 100 mg/L value was based on an acute toxicity test for *H. azteca* of 205 mg/L (96-hour LC₅₀), and incorporates a safety factor of 2. However, in April 2013 the BC MOE published an update to the sulphate water quality guideline based on a number of toxicity studies linking sulphate toxicity to water hardness, as discussed below.

Elphick et al. (2011) performed chronic toxicity tests on nine test organisms over four levels of water hardness (40, 80, 160, and 320 mg/L). For most test organisms, Elphick et al. (2011) observed a decrease in toxicity to test organisms as hardness increased. However, at a hardness of 320 mg/L, *C. dubia* showed increased sensitivity when compared to the test at 160 mg/L. Elphick et al. (2011) concluded that at higher hardness levels (greater than 250 mg/L), osmotic stress could be related to total dissolved solids and not elevated sulphate concentrations.

Pacific Environmental Science Centre conducted chronic toxicity tests on seven test organisms over three levels of water hardness (50, 100, and 150 mg/L) and also found decreasing sulphate toxicity with increasing water hardness. Dr. Chris Kennedy repeated the rainbow trout test under soft water conditions to clarify concerns with control mortality, and also found lowered sulphate toxicity when hardness increased up to 250 mg/L (BC MOE, 2013).

BC MOE has set updated sulphate guidelines (see Table 4.34 and Figure 4.13) based on 21-d rainbow trout embryo to alevin life stage LC₂₀ data at different levels of hardness from the Kennedy study and incorporating a safety factor of 2 (BC MOE, 2013). BC MOE sets guidelines using the critical value approach – using the lowest toxicity test result and applying a safety factor.

Table 4.34: Sulphate Water Quality Guidelines based on Water Hardness

Water Hardness (mg/L)	Sulphate Guideline (mg/L)
Very soft (0-30)	128
Soft to moderately soft (31-75)	218
Moderately soft/hard to hard (76-180)	309
Very hard (181-250)	429
>250	Need to determine based on site water

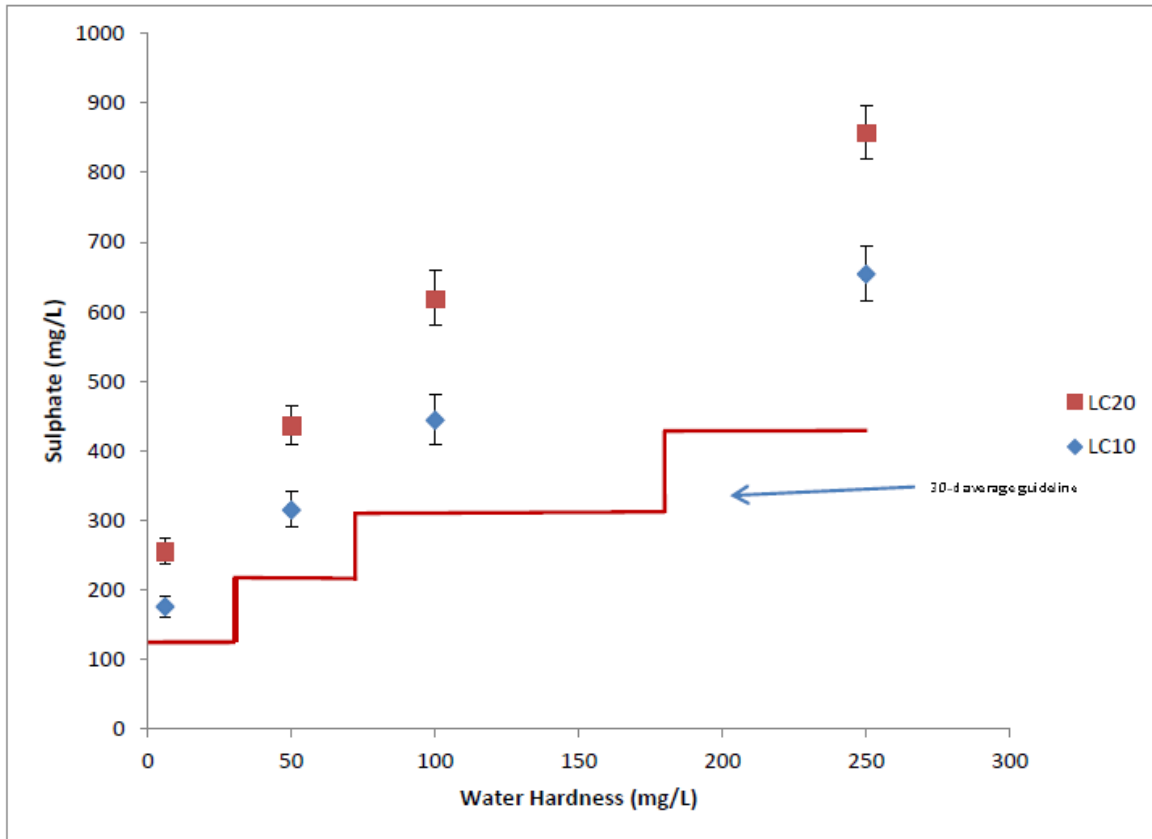

Figure 4.13: Relationship between Sulphate Toxicity and Water Hardness (BC MOE, 2013)

Terrestrial plant and invertebrate benchmarks are based on soil concentrations. The values are Canadian soil quality guidelines (industrial soil contact values) (CCME, 1999a), provincial soil quality guidelines (industrial plant and soil organism values) (MOE, 2011) or Lowest Observable Effect Concentration (LOEC) soil concentrations from Efroymson et al. (1997a,b). The Efroymson values are specific to either earthworms (1997a) or plants (1997b) but are conservative screening levels. Where an Efroymson value was higher than the more stringent of the CCME or MOE guideline values, which occurred only for earthworms, the Efroymson value was used as the benchmark, because it was specific to the terrestrial invertebrate indicator species (earthworm) selected for the EcoRA.

However, if the Efroymson value was lower than the more stringent of the CCME or MOE guideline values, then the more stringent guideline value was used as a benchmark, because these guidelines are considered by the responsible authorities to be adequately protective of plants and soil organisms. The terrestrial plant and invertebrate benchmarks are summarized in Table 4.37.

The benchmark values for birds and mammals (aquatic and terrestrial) are based on doses. The benchmark doses used are the LOAEL values from Sample *et al.* (1996), EC/HC (2011) for hydrazine, and WHO (1996) for morpholine. There were no data available for the

toxicity of hydrazine and morpholine for birds, and iron and sodium for mammals and birds. Hydrazine and morpholine are concerns in the aquatic environment, but due to their rapid degradation in the aquatic system and low octanol-water partition coefficient, the bioaccumulation of hydrazine and morpholine in the food chain is unlikely (EC/HC, 2011). Petroleum hydrocarbon F4 is not a toxicological concern for mammals and birds; therefore TRVs are not warranted (CCME, 2008). The mammal and bird benchmarks used are summarized in Table 4.38 and Table 4.39, respectively.

Table 4.35: Toxicological Benchmarks for Aquatic Receptors

COPC	Receptor	Water TRV (mg/L)	Endpoint	Test Species	Reference
Aluminum	Fish and Frog	3.29E+00	LCV	28-day embryo-larval tests with <i>Pimephales promelas</i>	Kimball, n.d. (cited in Suter and Tsao, 1996)
	Aquatic Plant	4.60E-01	LCV	4-day <i>Selenastrum capricornutum</i>	EPA, 1988 (cited in Suter and Tsao, 1996))
	Benthic Invertebrate	1.90E+00	LCV	<i>Daphnia magna</i>	McCauley et al., 1986 (cited in Suter and Tsao, 1996)
Chlorine (TRC)	Fish and Frog	5.90E-03	96h LC ₅₀ converted to EC ₂₀	Rainbow trout (<i>O. mykiss</i>)	Fisher <i>et al.</i> 1999 (cited in CCME, 1999a)
	Aquatic Plant	5.00E-03	LAV converted to EC ₂₀	Growth of <i>Myriophyllum spicatum</i>	Watkins and Hammerschlag, 1984 (cited in CCME 1999a)
	Benthic Invertebrate	3.20E-03	48h LC ₅₀ converted to EC ₂₀	<i>Daphnia magna</i>	Fisher <i>et al.</i> 1999 (cited in CCME, 1999a)
Copper	Fish and Frog	3.80E-03	LCV	Early life stage test on brook trout (<i>Salvelinus fontinalis</i>)	Sauter <i>et al.</i> , 1976 (cited in Suter and Tsao, 1996)
	Aquatic Plant	2.00E-03	Water quality guideline	-	CCME, 1999
	Benthic Invertebrate	6.07E-03	LCV	<i>Gammarus pseudolimnaeus</i>	Arthur and Leonard, 1970, (cited in Suter and Tsao, 1996)
Iron	Fish and Frog	1.30E+00	LCV	Mortality Rainbow Trout	Amelung, 1981 (cited in Suter and Tsao, 1996)
	Aquatic Plant	1.49E+00	EC ₅₀ converted to EC ₂₀	Growth of <i>Lemna minor</i>	Wang, 1986 (cited in BC MOE, 2008)
	Benthic Invertebrate	3.00E-01	Water quality guideline	-	CCME, 1999

COPC	Receptor	Water TRV (mg/L)	Endpoint	Test Species	Reference
Sodium	Fish and Frog	1.15E+02	EC ₁₀ (Na component of Na ₂ SO ₄)	Developmental effects on <i>Oncorhynchus mykiss</i>	Elphick et al, 2011
	Aquatic Plant	1.71E+02	EC ₂₅ (Na component of Na ₂ SO ₄)	Growth of <i>Fontinalis antipyretica</i>	Elphick et al, 2011
	Benthic Invertebrate	6.80E+02	LCV	Reproductive effects on <i>Daphnia magna</i>	Biesinger and Christensen, 1972 (cited in Suter and Tsao, 1996)
Hydrazine	Fish and Frog	6.1E-02	LC ₅₀ (96 hour) converted to chronic	Common guppy (<i>Lebistes rericulatus</i>)	Slonim, 1977 (cited in EC, 2013)
	Aquatic Plant	2.60E-03	FEQG (HC ₅ acute, converted to chronic)	-	EC, 2013
	Benthic Invertebrate	4.00E-03	LC ₅₀ (48 hour) converted to chronic	Amphipod (<i>Hyalella azteca</i>)	Fisher <i>et al.</i> , (cited in EC, 2013)
Morpholine	Fish and Frog	1.80E+01	LC ₅₀ (96 hour) converted to chronic	Mortality Rainbow trout (<i>Oncorhynchus mykiss</i>) (low hardness)	WHO, 1996
	Aquatic Plant	2.80E+00	EC ₅₀ (96 hour) converted to chronic	Impairment/mortality Algae (<i>Selenastrum capricornutum</i>)	WHO, 1996
	Benthic Invertebrate	1.00E+01	EC ₅₀ (24 hour static) converted to chronic	<i>Daphnia magna</i>	WHO, 1996

Table 4.36: Toxicological Benchmarks for Benthic Invertebrates

COPC	Benthic Invertebrate (mg/kg dw)	Reference
Copper	1.60E+01	Sediment LEL (MOE, 2011)
Iron	2.12E+04	Sediment LEL (MOE, 2011)

Table 4.37: Toxicological Benchmarks for Soil for Terrestrial Invertebrates and Plants

COPC	Soil Invertebrate (mg/kg)	Reference	Terrestrial Plant (mg/kg)	Reference
Arsenic	6.00E+01	Efroymson, 1997a	2.60E+01	CCME, 1999a
Copper	9.10E+01	CCME, 1999a	1.00E+01	Efroymson, 1997b
Lead	6.00E+02	CCME, 1999a	6.00E+02	CCME, 1999a
Zinc	2.00E+02	Efroymson, 1997a	2.00E+02	CCME, 1999a
Cyanide	8.00E+00	CCME, 1997	8.00E+00	CCME, 1997
Petroleum Hydrocarbon F4	3.30E+03	MOE, 2011	3.30E+03	MOE, 2011

Table 4.38: Selected Toxicity Reference Values for Mammals (Aquatic and Terrestrial)

COPC	Mammal LOAEL (mg/kg-d)	Test Species	Endpoint	Test Duration	Reference
Aluminum	1.93E+01	mouse	reproduction	3 generations	Ondreicka et al, 1966 (cited in Sample <i>et al.</i> , 1996)
Arsenic	1.26E+00	mouse	reproduction	3 generations	Schroeder and Mitchner, 1971 (cited in Sample <i>et al.</i> , 1996)
Chlorine (TRC)	5.00E+01	rat	body weight	92 days	Furukawa <i>et al.</i> , 1980 (cited in HHA, 2010)
Copper	1.51E+01	mink	reproduction	375 days	Aulerich <i>et al.</i> , 1982 (cited in Sample <i>et al.</i> , 1996)
Lead	8.00E+01	rat	reproduction	3 generations	Azar <i>et al.</i> , 1973 (cited in Sample <i>et al.</i> , 1996)
Iron	1.82E+03	Rat	growth	91 days	Storey and Greger, 1987
Zinc	3.20E+02	rat	reproduction	days 1-16 of gestation	Schlicker and Cox, 1968 (cited in Sample <i>et al.</i> , 1996)
Hydrazine	1.87E+00	mouse	lung tumour	110-120 weeks	Roe <i>et al.</i> , 1967; Toth, 1969, 1972 (cited in EC/HC, 2011)
Morpholine	9.00E+00	guinea pig	mortality	30 days	WHO, 1996
Cyanide	6.87E+01	rat	reproduction	during gestation and lactation stage	Tewe and Maner, 1980 (cited in Sample <i>et al.</i> , 1996)
Petroleum HydrocarbonF4	N/A	-	-	-	-

Notes:

The TRV for cyanide is a NOAEL. No adverse effects were observed at 500 mg/kg in diet.

The TRV for morpholine is a chronic EC₂₀ value, converted from an acute LD₅₀ using a factor of 10.

Iron TRV was presented as 3042 mg/kg diet (modified by factoring in body weight of 0.4 kg and food ingestion of 0.24 kg/d from BC MOE, 1996).

Table 4.39: Selected Toxicity Reference Values for Birds

COPC	Bird LOAEL (mg/kg-d)	Test Species	Endpoint	Test Duration	Reference
Aluminum	1.10E+02	ringed dove	reproduction	4 months	Carriere et al., 1986 (cited in Sample et al., 1996)
Arsenic	1.28E+01	mallard duck	mortality	128 days	USFWS, 1964 (cited in Sample et al., 1996)
Chlorine (TRC)	nd	-	-	-	-
Copper	6.17E+01	1 day old chicks	growth, mortality	10 weeks	Mehring et al., 1960 (cited in Sample et al., 1996)
Iron	4.65E+01	chicken	growth	22 days	Vahl and Van T'Klooster, 1987
Lead	1.13E+01	Japanese quail	reproduction	12 weeks	Edens et al., 1976 (cited in Sample et al., 1996)
Zinc	1.31E+02	white leghorn hens	reproduction	44 weeks	Stahl et al., 1990 (cited in Sample et al., 1996)
Hydrazine	nd	-	-	-	-
Morpholine	nd	-	-	-	-
Cyanide	0.21	American kestrel	Mortality		Weimeyer et al. 1986 (cited in EC, 1999)
Petroleum Hydrocarbon F4	N/A	-	-	-	-

Note:

nd = no data available

Cyanide TRV incorporates a safety factor of 10 for acute to chronic.

Iron TRV was presented as 680 mg/kg diet (modified by factoring in body weight of 1.9 kg and food ingestion of 0.13 kg/d from BC MOE, 1996).

4.3.2 Radiation Benchmarks

Radiation dose benchmarks of 400 $\mu\text{Gy/h}$ (9.6 mGy/d) and 100 $\mu\text{Gy/h}$ (2.4 mGy/d) (UNSCEAR, 2008) were selected for the PN assessment of effects on aquatic biota and terrestrial biota, respectively, as recommended in the CSA N288.6-12 standard (CSA, 2012). This is a total dose benchmark, therefore the dose to biota due to each radionuclide of concern is summed to compare against this benchmark.

The aquatic biota dose benchmark of 10 mGy/d was initially developed by the NCRP (1991) and was recommended by the IAEA (1992) which concluded that limiting the dose rate to individuals in an aquatic population to a maximum of 10 mGy/d would provide adequate protection for the population. Later reviews by the United Nations Scientific Committee on the Effects of Atomic Radiation (UNSCEAR) (1996, 2008) have supported this recommendation.

The aquatic biota considered by UNSCEAR are organisms such as fish and aquatic invertebrates that reside in water. Birds and mammals with riparian habits are considered to be terrestrial biota. Dose calculations in this ERA follow the same convention.

For terrestrial biota, a level of 1 mGy/d has been widely used as an acceptable level based on IAEA (1992) and UNSCEAR (1996). More recently, UNSCEAR (2008) has supported a slightly higher exposure level of 100 μ Gy/h (2.4 mGy/d) as the threshold for effects of population significance in terrestrial organisms. UNSCEAR (2008) updated its review of radiation effects on natural biota, and noted that the 0.04 mGy/h (1 mGy/d) exposure produced no effect in the most sensitive mammalian study (with dogs), while 0.18 mGy/h produced eventual sterility. Therefore, UNSCEAR chose an intermediate exposure level of 0.1 mGy/h (2.4 mGy/d) as the threshold for effects of population significance in terrestrial organisms. UNSCEAR concluded that lower dose rates to the most highly exposed individuals would be unlikely to have significant effects on most terrestrial communities.

It is recognized that the selection of reference dose levels is a topic of ongoing debate. For example, the CNSC has recommended dose limit values of 0.6 mGy/d for fish, 3 mGy/d for aquatic plants (algae and macrophytes), 6 mGy/d for benthic invertebrates (aquatic invertebrates and zooplankton in this assessment), and 3 mGy/d for terrestrial animals and plants (Bird *et al.*, 2002; EC/HC, 2003). The dose limit value for fish was based on a reproductive effects study in carp in a Chernobyl cooling pond with a history of higher exposures (Makeeva *et al.*, 1995). A value of 0.6 mGy/d was found to be in the range where both effects and no effects were observed. The aquatic plant benchmark was based on information related to terrestrial plants (conifers), which are considered to be sensitive to the effects of radiation. Reproductive effects in polychaete worms were used to derive the dose limit for benthic invertebrates.

The International Commission on Radiological Protection (ICRP) (2008) has suggested “derived consideration levels” as a range of dose rates reflecting a range in potential for effect, for each of several taxonomic groups. The ICRP states that the ranges of dose rates they provide are preliminary and need to be revised as more data become available.

Considering the history and discussions surrounding the selection of radiation benchmarks, 400 μ Gy/h (9.6 mGy/d) and 100 μ Gy/h (2.4 mGy/d) (UNSCEAR, 2008) were selected for the assessment of effects on aquatic biota and terrestrial biota, respectively. These benchmarks were recommended in CSA N288.6-12 (CSA, 2012), and are appropriate for this assessment.

4.3.3 Thermal Benchmarks

Golder (2007b) determined maximum weekly average water temperature (MWAT) criteria relevant to fish spawning and embryo-larval development, based on review of thermal effects literature (e.g., Wismer and Christie, 1987) and following methods outlined in section 304(a) of the U.S. EPA Clean Water Act. These benchmarks (Table 4.44) represent an upper bound of temperature suitable for embryo and larval development under chronic exposure conditions. Golder (2007b) also determined MWAT criteria relevant to growth of juvenile and adult fish (Table 4.49). Criteria were defined for two warm water fish species (Smallmouth Bass and Emerald Shiner) and two cold water species (Round Whitefish and

Lake Trout), which were selected as representative species for assessment of thermal effects.

Cooper (2013) considered MWAT criteria and short-term daily maximum (STDM) criteria relevant to fish spawning and embryo-larval development (Table 4.45), as well as MWAT criteria and STDM criteria relevant to growth of juvenile and adult fish (Table 4.49). The STDM criteria represent upper bound temperatures considered suitable for short periods (24 hours). Both criteria were defined for 15 species found in the vicinity of the Pickering station.

Assessment of thermal effects on Round Whitefish embryos is of particular interest as Round Whitefish is considered to be the most sensitive fish species to elevated water temperatures during the winter months. Lake Whitefish are more tolerant of warmer temperatures than Round Whitefish (i.e., Griffiths (1980) assumed Round Whitefish spawn at 3.9°C whereas Lake Whitefish were assumed to spawn at 5.8°C). Whitefish have an extended period of egg incubation and embryo development that extends from December into March to mid-April making them particularly susceptible to thermal effects over the incubation period.

For these reasons, OPG (2017) assessed the potential effects of the thermal plume on survival of Round Whitefish embryos. The assessment included the use of a thermal survival model to estimate survival loss due to elevated water temperatures in the thermal plume, and the comparison of average water temperature in the thermal plume with the threshold effect level of 6°C. In addition, the possible effects of short-term periodic increases in water temperature in the thermal plume on Round Whitefish was assessed by comparing the total number of hours that water temperature exceeded 10°C in the thermal plume and in the reference areas, and the maximum temperature reached at each station during the winter, with the chronic toxicity data for Round Whitefish embryo survival in Griffiths' (1980) study.

4.3.4 Uncertainties in the Effects Assessment

Toxicological benchmarks used in the risk assessment were selected from sources recommended in the CSA N288.6-12 (CSA, 2012) standard, and other reputable sources. These BVs represent the low end of threshold effect levels in literature for each receptor category. BVs for the test species were not adjusted for body weight and were considered directly applicable to the wildlife species. The BVs are considered to be conservatively representative of the effect threshold for the COPC for the receptor of interest. There is uncertainty because most species of interest have not been tested to determine their effect thresholds. Nevertheless, it is expected that few species will be much more sensitive than indicated by the selected benchmark values.

Also, toxicological benchmarks are not available for certain COPCs (e.g., sodium for terrestrial birds), therefore no quantitative assessment was carried out. Without the

benchmark value, it is difficult to determine potential effects for these biota. However, areas with elevated levels of these COPCs are limited; therefore, these uncertainties are unlikely to have major effects on the overall conclusions of the risk assessment.

Radiation dose benchmarks for biota are a topic of ongoing debate. Uncertainties exist related to some low values that have been suggested based on field studies around Chernobyl. The radiation dose benchmarks chosen follow UNSCEAR (2008) and CSA N288.6-12 (CSA, 2012) in giving more credence to values based on controlled laboratory studies and demonstrated low levels of effect.

Thermal benchmarks represent a variety of species, life stages and endpoints, and vary among literature sources. Selected values vary among literature sources and have varied somewhat among studies of thermal effects at the Pickering station.

4.4 Risk Characterization

4.4.1 Risk Estimation

Ecological risk is estimated by dividing the EV (Section 4.2.5) by the BV (Section 4.3) for a given COPC and receptor species, yielding a HQ. When the EV for an organism at a site exceeds the BV ($HQ > 1$), a potential for adverse ecological effects is inferred. A summary of the radiation doses to each receptor by COPC is presented in Table 4.40, and a summary of non-radiological HQs is presented in Table 4.41 through Table 4.43.

Table 4.40: Summary of Radiation Dose Estimates for Biota at the Pickering Site (mGy/d)

COPC	Tritium		Carbon-14		Cobalt-60		Cesium-134		Cesium-137		Argon-41		Total Dose	
	max	mean	max	mean	max	mean	max	mean	max	mean	max	mean	max	mean
PN Outfall														
Pelagic Fish	1.76E-05	7.65E-06	7.64E-05	4.82E-06	2.20E-05	2.01E-06	-	-	-	-	-	-	1.16E-04	1.45E-05
Bottom Dwelling Fish	1.76E-05	7.65E-06	7.65E-05	4.86E-06	2.50E-05	4.04E-06	-	-	-	-	-	-	1.19E-04	1.65E-05
Benthic Invertebrate	1.76E-05	7.67E-06	8.99E-05	1.11E-05	2.55E-05	9.90E-06	-	-	-	-	-	-	1.33E-04	2.86E-05
Ring-billed Gull	1.29E-04	4.53E-05	7.65E-04	3.00E-04	4.78E-05	4.05E-05	-	-	-	-	1.30E-05	5.35E-06	9.55E-04	3.91E-04
Frenchman's Bay														
Pelagic Fish	1.68E-06	1.39E-06	1.74E-03	7.54E-04	3.06E-05	3.06E-05	1.72E-03	1.72E-03	1.54E-03	1.54E-03	-	-	5.03E-03	4.04E-03
Bottom Dwelling Fish	1.68E-06	1.39E-06	1.74E-03	7.54E-04	3.37E-05	3.37E-05	1.72E-03	1.72E-03	1.54E-03	1.54E-03	-	-	5.04E-03	4.06E-03
Frog	1.68E-06	1.39E-06	1.74E-03	7.54E-04	1.49E-05	1.49E-05	8.16E-04	8.16E-04	1.12E-03	1.12E-03	-	-	3.69E-03	2.71E-03
Benthic Invertebrate	1.68E-06	1.39E-03	1.57E-03	6.80E-04	3.05E-05	3.05E-05	5.35E-05	5.35E-05	3.73E-05	3.22E-05	-	-	1.69E-03	7.98E-04
Aquatic Plant (Cattail)	1.68E-06	1.39E-06	1.71E-03	7.44E-04	1.02E-04	1.02E-04	3.88E-05	3.88E-05	5.26E-05	5.26E-05	-	-	1.91E-03	9.39E-04
Muskrat	1.41E-06	1.17E-06	2.89E-03	1.26E-03	1.16E-05	1.16E-05	1.04E-04	1.04E-04	8.51E-05	8.43E-05	2.27E-06	1.90E-06	3.09E-03	1.46E-03
Trumpeter Swan	1.36E-06	1.12E-06	3.51E-03	1.52E-03	1.73E-04	1.73E-04	1.28E-04	1.28E-04	1.06E-04	1.05E-04	2.27E-06	1.90E-06	3.92E-03	1.93E-03
Bufflehead	1.36E-06	1.12E-06	3.49E-03	1.51E-03	5.63E-05	5.63E-05	9.14E-05	9.14E-05	7.43E-05	7.33E-05	2.27E-06	1.90E-06	3.71E-03	1.74E-03
Common Tern	1.36E-06	1.12E-06	3.47E-03	1.51E-03	2.02E-05	2.02E-05	2.18E-03	2.18E-03	1.85E-03	1.85E-03	2.27E-06	1.90E-06	7.53E-03	5.56E-03
Ring-billed Gull	1.20E-04	4.17E-05	2.64E-03	1.15E-03	5.04E-05	5.04E-05	1.35E-03	1.35E-03	1.14E-03	1.14E-03	2.27E-06	1.90E-06	5.31E-03	3.73E-03
PN Site														
Earthworm	1.92E-03	6.55E-04	4.20E-05	1.43E-05	3.11E-05	3.11E-05	2.00E-05	2.00E-05	7.33E-06	7.33E-06	-	-	2.02E-03	7.28E-04
Terrestrial Plant	6.80E-05	2.33E-05	3.56E-05	1.21E-05	1.08E-05	1.08E-05	2.47E-06	2.47E-06	2.67E-06	2.67E-06	1.30E-05	5.35E-06	1.20E-04	5.13E-05
Meadow Vole	3.58E-05	1.29E-05	7.61E-05	2.58E-05	1.20E-05	1.20E-05	7.42E-06	7.42E-06	2.72E-06	2.72E-06	1.30E-05	5.35E-06	1.34E-04	6.08E-05
Red-winged Blackbird	1.24E-03	4.24E-04	9.24E-05	3.14E-05	1.12E-05	1.11E-05	7.14E-06	7.14E-06	2.77E-06	2.77E-06	1.30E-05	5.35E-06	1.35E-03	4.77E-04
Red Fox	2.19E-05	8.37E-06	1.14E-03	4.92E-04	1.55E-05	1.55E-05	1.50E-05	1.50E-05	2.106E-05	2.10E-05	1.30E-05	5.35E-06	1.22E-03	5.51E-04
Red-tailed Hawk	2.37E-04	8.15E-05	9.32E-05	3.16E-05	1.11E-05	1.10E-05	7.10E-06	7.10E-06	2.69E-06	2.69E-06	1.30E-05	5.35E-06	3.51E-04	1.34E-04

Notes:

Bold and shaded values exceed the aquatic benchmark of 9.6 mGy/d or the terrestrial benchmark of 2.4 mGy/d.

Max and mean dose for Cobalt-60, Cesium-134, and Cesium-137 are generally equivalent for most receptors since surface water, sediment, and soil concentrations were generally measured below the detection limit.

Table 4.41: Non-Radiological Hazard Quotients for Terrestrial Biota

Receptor	Arsenic		Copper		Lead		Zinc		Cyanide		Petroleum Hydrocarbon F4	
	max	mean	max	mean	max	mean	max	mean	max	mean	max	mean
Earthworm	1.0	0.1	9.1	0.8	0.5	0.1	16.0	1.4	0.0	0.0	1.7	0.5
Terrestrial Plant	2.2	0.2	8.3	0.7	0.9	0.1	16.0	1.4	0.0	0.0	1.7	0.5
Meadow Vole	0.8	0.1	2.8	0.2	0.0	0.0	0.8	0.1	0.0	0.0	N/A	N/A
Red-winged Blackbird	0.2	0.0	1.2	0.1	1.2	0.1	10.0	0.9	0.0	0.0	N/A	N/A
Red Fox	0.1	0.0	0.2	0.0	0.0	0.0	0.3	0.0	0.0	0.0	N/A	N/A
Red-Tailed Hawk	0.3	0.0	0.8	0.1	1.1	0.1	1.5	0.1	0.1	0.0	N/A	N/A

Notes:

Bold and shaded values indicate a HQ > 1

N/A denotes that HQs were not calculated because COPC is not of toxicological concern to receptor.

Table 4.42: Non-Radiological Hazard Quotients for Aquatic Biota and Riparian Birds and Mammals

Receptors	Hydrazine		Morpholine		Chlorine (TRC)		Copper		Aluminum		Sodium		Iron	
	max	mean	max	mean	max	mean	max	mean	max	mean	max	mean	max	mean
PN Outfall														
Fish	0.0	0.0	0.0	0.0	0.2	0.2	2.3	0.3	N/A	N/A	N/A	N/A	N/A	N/A
Benthic Invertebrate	0.1	0.0	0.0	0.0	0.4	0.4	1.5	0.4	N/A	N/A	N/A	N/A	N/A	N/A
Ring-billed Gull	nd	nd	nd	nd	nd	nd	0.1	0.4	N/A	N/A	N/A	N/A	N/A	N/A
Frenchman's Bay														
Fish	0.0	0.0	0.0	0.0	0.2	0.2	0.6	0.4	0.1	0.0	0.8	0.5	0.4	0.2
Frog (Tadpole)	0.0	0.0	0.0	0.0	0.2	0.2	0.6	0.4	0.1	0.0	0.8	0.5	0.4	0.2
Benthic Invertebrate	0.0	0.0	0.0	0.0	0.4	0.4	0.3	0.3	0.1	0.1	0.1	0.1	1.9	0.9
Aquatic Plant (Cattail)	0.0	0.0	0.0	0.0	0.2	0.2	1.1	0.8	0.6	0.3	0.5	0.3	0.4	0.2
Muskrat	0.0	0.0	0.0	0.0	0.0	0.0	0.1	0.1	5.2	3.0	N/A	N/A	0.3	0.2
Trumpeter Swan	nd	nd	nd	nd	nd	nd	0.0	0.0	0.4	0.2	N/A	N/A	5.2	2.7
Bufflehead	nd	nd	nd	nd	nd	nd	0.0	0.0	4.1	2.3	N/A	N/A	17.3	9.9
Common Tern	nd	nd	nd	nd	nd	nd	0.0	0.0	0.2	0.1	N/A	N/A	1.0	0.6
Ring-billed Gull	nd	nd	nd	nd	nd	nd	0.1	0.0	0.6	0.4	N/A	N/A	5.0	2.8

Notes:

Bold and shaded values indicate a HQ > 1

nd denotes that no data were available

N/A denotes that parameter not applicable to specific area of assessment

Max and mean HQs for morpholine and TRC are generally equivalent for most receptors since surface water concentrations were generally measured below the detection limit

The HQs for fish, frog, benthic invertebrate, and aquatic plant are based on TRVs for water concentrations

Sodium is considered non-toxic to birds and mammals

Table 4.43: Non-Radiological Hazard Quotients for Benthic Invertebrates from Sediment TRVs

		Benthic Invertebrate	
		PN Outfall	Frenchman's Bay
Copper	max	1.5	4.6
	mean	0.3	2.8
Iron	max	N/A	1.0
	mean	N/A	0.8

Notes:

Bold and shaded values indicate a HQ > 1

N/A denotes that parameter not applicable to specific area of assessment

4.4.2 Discussion of Chemical and Radiation Effects

4.4.2.1 Effects Monitoring Evidence

Data used for the problem formulations, screening and ecological risk assessment were taken from the most recent environmental studies conducted at the PN site. These sources include the 2015 updated baseline environmental monitoring program, the 2014 ERA (EcoMetrix, 2014), recent monitoring reports from the East Landfill, annual EMP reports, annual compliance reports, the 2007 EA and its associated TSDs. No additional data are available to what is presented at this time to clarify potential effects at the site.

4.4.2.2 Likelihood of Effects

4.4.2.2.1 Outfall

Radiological

There are no exceedances of the 9.6 mGy/d radiation benchmark for the aquatic biota at the outfall location including fish and benthic invertebrates. The 2.4 mGy/d radiation benchmark is not exceeded for the Ring-billed Gull. The radiation dose to aquatic biota is mainly driven by carbon-14 in water.

Non-Radiological

Maximum and mean measured concentrations of hydrazine, morpholine, and total residual chlorine in the outfall did not exceed their respective benchmarks for the receptors of interest.

Based on maximum measured copper concentrations in water near the PN outfall, the fish and benthic invertebrate benchmarks were exceeded; therefore the risk (HQ) was above the acceptable risk level of 1. Based on mean copper concentrations in water near the PN outfall, the risk level for fish and benthic invertebrates was acceptable. Since fish swim around, exposure to the mean concentration is more likely. Although a few benthic invertebrates may be exposed to these maximum measured concentrations, the community as a whole is not expected to be affected.

Based on estimated maximum copper concentrations in sediment near the PN outfall, the sediment benchmark for copper was exceeded; therefore the risk (HQ) was marginally above the acceptable risk level of 1. The estimated maximum copper concentration in sediment is based on the maximum measured copper concentration in lake surface water with a sediment partition coefficient (K_d) applied; therefore, there is uncertainty around the sediment concentration. Based on mean measured copper concentrations near the PN outfall, the estimated sediment concentration is below the sediment benchmark for copper; therefore, effects are not expected to the benthic invertebrate community. Additionally,

there is uncertainty surrounding this risk as sediment in Lake Ontario is transient, and the invertebrate community is mainly epifaunal.

The American Eel is identified as a species at risk; therefore the assessment endpoint is the health of the individual. As discussed above, the fish benchmark was exceeded in the outfall for maximum measured water concentrations of copper. However, based on mean measured water concentrations the fish benchmarks were not exceeded for copper. Since fish swim around a wider area, the HQs for mean water concentrations are more representative than maximum concentrations. As such, the American Eel is likely not at risk from PN operations.

4.4.2.2.2 Frenchman's Bay

Radiological

There are no exceedances of the 9.6 mGy/d aquatic radiation benchmark for any aquatic receptors at Frenchman's Bay. There are also no exceedances of the 2.4 mGy/d terrestrial radiation benchmark for birds and mammals at Frenchman's Bay.

Non-Radiological

Maximum and mean measured concentrations of morpholine, total residual chlorine, and sodium at Frenchman's Bay did not exceed the benchmark for any of the aquatic biota identified at Frenchman's Bay.

Maximum and mean modelled concentrations of hydrazine at Frenchman's Bay did not exceed the benchmark for any of the aquatic biota identified at Frenchman's Bay. The benchmark used in the 2014 ERA (EcoMetrix, 2014) was an algal EC₅₀ from the data set used to derive the Federal Water Quality Guideline (a 72-hour EC₅₀ of 0.012 mg/L for algal growth, converted to a chronic value (1.2 µg/L). However, in this assessment, the aquatic plant benchmark used was the FEQG of 2.6 µg/L, since this guideline value is considered protective for all aquatic life (EC, 2013). Maximum concentrations are based on measured lake water data from 2014 from the vicinity of the PN outfalls (EcoMetrix, 2015) with a dilution factor to Frenchman's Bay applied.

There were no toxicity data for hydrazine for birds, as discussed in Section 4.3.1; therefore risks were not calculated for hydrazine to birds. Hydrazine is not expected to be of concern for birds due to the low risk of food chain bioaccumulation.

The maximum measured copper concentration in water at Frenchman's Bay is 2.1 µg/L, which marginally exceeds the aquatic plant benchmark of 2 µg/L. Measured copper concentrations in water at Frenchman's Bay range from 1.4 to 2.1 µg/L. Based on maximum and mean measured copper concentrations in sediment in Frenchman's Bay, the sediment benchmarks were exceeded; therefore the HQ for benthic invertebrates in Frenchman's Bay marginally exceeded the acceptable risk level of 1. Although, the

acceptable risk level of 1 for copper was exceeded for benthic invertebrates based on measured sediment concentrations, the contribution from PN operations to the maximum and mean copper concentrations in water (and then partitioning to the sediment) at Frenchman's Bay is low ranging from 9 to 11 percent for copper (see Appendix E, Table E.9).

The maximum measured iron concentration in water at Frenchman's Bay exceeded the benthic invertebrate benchmark of 300 µg/L; however, the mean measured iron concentration in water at Frenchman's Bay was below the benthic invertebrate benchmark. Although a few benthic invertebrates may be exposed to these maximum measured concentrations, the community as a whole is not expected to be affected. Additionally, the maximum and mean measured iron concentrations in sediment at Frenchman's Bay did not exceed the sediment benchmarks for benthic invertebrates.

The HQs for aluminum for the muskrat; for aluminum and iron for the Bufflehead, and for iron for the Trumpeter Swan, Common Tern, and Ring-billed Gull exceeded the acceptable risk level of 1. With the exception of the Common Tern, the acceptable risk level of 1 was exceeded when receptors were exposed to both the maximum and mean measured water and sediment concentrations. Many of these receptors would not reside at Frenchman's Bay exclusively; therefore the HQs presented are conservative. Additionally, as discussed in Appendix E, exceedances of toxicity benchmarks are not uncharacteristic for an area such as Frenchman's Bay that is highly influenced by urban runoff. PN operations contribute a small proportion of the overall risk to aquatic receptors at Frenchman's Bay. The percent contribution from PN ranges from 0.3% to 22% over all COPCs (see Appendix E).

Least Bittern was identified as a species at risk on the PN site; therefore the assessment endpoint is the health of the individual. The representative species in this ERA is the Common Tern. As discussed above, the HQ for the Common Tern exceeded the acceptable risk level of 1 for maximum concentrations of iron. However, based on mean concentrations the HQ for the Common Tern did not exceed the acceptable risk level of 1. Since the Common Tern is mobile, mean exposure is more representative than maximum exposure. As such, the Least Bittern (represented by the Common Tern) is likely not at risk from iron exposure in Frenchman's Bay.

4.4.2.2.3 Pickering Nuclear Site

Radiological

There are no exceedances of the 2.4 mGy/d radiation benchmark for terrestrial biota on the PN site including earthworms, terrestrial plants, meadow vole, Red-winged Blackbird, red fox, and Red-tailed Hawk.

The 2014 ERA concluded that the total radiological dose benchmark was exceeded by the earthworm and Red-winged Blackbird based on the maximum tritium concentration in site

soil. The exceedance was based on localized, elevated tritium concentrations in soil close to the reactor buildings. As discussed in Section 4.1.3.3, updated soil data were collected in 2015. To inform the baseline sampling program a site inspection was performed to focus the program on areas with vegetation or organic soil cover. Based on the site inspection, the area near PN U1 and U2 were removed from the soil monitoring program as this is a paved area without suitable habitat for terrestrial receptors. As a result, the dose and risk results for this current ERA provide a more realistic assessment of existing conditions.

Non-Radiological

In general, soils on site that exceed benchmark concentrations are localized, suggesting the influence of past industrial operations rather than deposition from atmospheric sources. As such, COPC accumulation in soil over time is not expected. Instead, the range of concentrations should be reduced as affected areas are identified and cleaned up.

The HQs for copper for the meadow vole; for copper, lead and zinc for the Red-winged Blackbird; and for lead and zinc for Red-tailed Hawk, exceeded the acceptable risk level of 1 when exposure to maximum concentrations was assumed. However, these receptors, with the exception of the meadow vole, are highly mobile and are unlikely to be exposed to the maximum concentrations for the entire year. There are no exceedances for mammals or birds exposed to average concentrations in soil, therefore adverse effects are not expected. The higher HQ value for copper for the meadow vole is driven by maximum modelled concentrations in terrestrial plants. The maximum copper concentration in the plant is localized to one sampling location (Site 14 SS5, see Figure 4.5). Therefore any effects on the meadow vole due to copper intake are limited to one area. Although localized effects to individual VECs may occur, the populations on the site as a whole are not expected to be affected.

The higher HQ value for zinc for the Red-winged Blackbird is driven by maximum concentrations in earthworms. Although the Red-winged Blackbird primarily eats insects, for this assessment the earthworm was used as a surrogate for all insects and invertebrates, which is probably conservative. Additionally, the Red-winged Blackbird is mobile; therefore exposure to average concentrations in soil is more likely. The HQ for zinc based on mean concentrations was below the acceptable risk level of 1; therefore, adverse effects are not expected.

Barn Swallow is identified as species at risk; therefore the assessment endpoint is the health of the individual. The representative species in this ERA is the Red-winged Blackbird. As discussed above, HQs for the Red-winged Blackbird exceeded the acceptable risk level of 1 for maximum concentrations of copper, lead, and zinc in soil. However, based on mean concentrations HQs for copper, lead, and zinc did not exceed the acceptable risk level of 1. Since birds are mobile, mean exposure is more representative than maximum exposure. As such, the Barn Swallow is likely not at risk from PN operations.

Copper (maximum), zinc (maximum and mean), and petroleum hydrocarbon F4 (maximum) soil exposure concentrations exceeded benchmark values for earthworms. Although localized effects to individual earthworms may occur, the earthworm community on the site as a whole are not expected to be affected.

Maximum soil concentrations of arsenic, copper, zinc, and petroleum hydrocarbon F4 exceeded benchmark values for terrestrial plants. Mean soil concentrations of zinc also exceeded benchmark values for terrestrial plants. The potential effects on plants due to exposure to arsenic, copper, and petroleum hydrocarbon F4 are expected to be limited to small areas at the PN site. The toxicological benchmarks for these COPCs were exceeded at only 1 out of the 8 sampling locations at the PN site. Arsenic, copper, and petroleum hydrocarbon F4 benchmarks were exceeded at Site 14 SS5 (East Site - ditch north of the east site warehouse, see Figure 4.5). The zinc benchmarks were exceeded at GMS-28, GMS-31, Site 14 SS3 (2 locations), Site 14 SS5 (2 locations), and Site 14 SS6, as shown on Figure 4.5. Although localized effects to individual terrestrial plants may occur, the plant populations on the site as a whole are not expected to be affected.

Butternut is identified as a species at risk; therefore, the assessment endpoint is the health of the individual. The representative species in this ERA is Red ash (terrestrial plant). While individual plants may be exposed to concentrations above the soil benchmark, there are no trees in these areas of maximum soil concentrations, therefore, Butternut is not at risk in the localized areas of benchmark exceedance.

HQs for exposure of terrestrial mammals and birds to petroleum hydrocarbon F4 were not calculated. Petroleum hydrocarbon F4 is not a toxicological concern for mammals and birds (CCME, 2008).

Pickering Waste Management Facility

The maximum dose rate to any ecological VEC residing in close proximity to the PWMF could be up to 0.012 mGy/d, lower than the 2.4 mGy/d radiation benchmark for terrestrial biota. The dose also remains below the radiation benchmark if the maximum dose from the PWMF is combined with the dose to ecological VECs from being exposed to radionuclides through other existing PN operations (Table 4.40).

4.4.2.2.4 East Landfill

As discussed in Section 4.3.1, the BC MOE has published a sulphate water quality guideline based on a number of toxicity studies linking sulphate toxicity to water hardness. The BC guideline states that if natural hardness is greater than 250 mg/L site-specific toxicity testing on several species should be conducted, since the combination of high water hardness and sulphate levels may cause osmotic stress on the organism, likely related to high levels of total dissolved solids. The highest hardness level observed at the East Landfill was 752 mg/L in 2010 from Ditch 6, with a sulphate concentration of 328 mg/L. Although there is uncertainty in the sulphate benchmark at hardness levels above

250 mg/L, the observed sulphate concentration in Ditch 6 is well below the LC₂₀ for trout of 857 mg/L at a hardness of 250 mg/L (BC MOE, 2013) as well as the LC₂₅ for *C. dubia* of 425 mg/L at a hardness of 320 mg/L (Elphick et al., 2011). The maximum sulphate in Ditch 6 is below these effect levels as well as below the sulphate guideline at the maximum hardness. Based on these observations, sulphate levels in Ditch 6 are not likely of concern.

4.4.3 Thermal Effects

4.4.3.1 Thermal Plume Effects on Fish Eggs and Larvae

The potential effects of the thermal plume on fish eggs and larvae were evaluated in the Aquatic Environment TSD for the EA for the refurbishment and continued operation of PN Units 5-8 (Golder, 2007b). The thermal regime as influenced by the existing plume was determined by numerical modelling which described the seasonal and spatial variation in water temperature. The modelled MWATs were compared to MWAT criteria representing an upper bound of temperature suitable for fish embryo and larval development under chronic exposure conditions. Similar evaluations of thermal plume effects on fish eggs and larvae were performed by Cooper (2013) using measured MWATs and STDMS from temperature dataloggers compared to MWAT criteria and STDMS criteria. Results from both studies are presented in this section.

For Round Whitefish, the thermal threshold effect level of 6°C for eggs and larvae is used in preference to MWAT criteria, and models predicting embryo survival have been developed. The evaluation of embryo-larval development for Round Whitefish is presented in Section 4.4.3.1.1. Thermal effects on growth of juvenile and adult fish are considered in Section 4.4.3.2.

The MWAT criteria from Golder (2007b) for embryo and larval development, for Smallmouth Bass, Emerald Shiner and Lake Trout, are shown in Table 4.44. These criteria are calculated from an optimum temperature and an upper lethal temperature, as per the section 304(a) of the U.S. EPA Clean Water Act. They are applicable during the relevant timeframe for embryo-larval development.

Table 4.44: Thermal Criteria Relevant to Embryo and Larval Development of Selected Fish Species (Golder, 2007b)

Fish Species	Life Stage	Optimum Temp (°C)	Upper Lethal Temp (°C)	MWAT Criteria (°C)	Relevant Timeframe
Smallmouth Bass	Embryo	18	37	24.3	mid-Apr-May
	Larvae	21	33	25	mid-Apr-May
Emerald Shiner	Embryo	24	29	27	mid-Apr-May
	Larvae	24	29	27	mid-Apr-May
Lake Trout	Embryo	-	14.8	10	December
	Larvae	-	14.8	10	Dec- Apr

The cold water species (Round Whitefish and Lake Trout) spawn on shoals and rocky substrates located in the shallow nearshore waters east of the PN generating station. Lake Trout spawn in December. The larval periods for both species extend into April.

Among the warm water species, Smallmouth Bass spawn primarily within the intake and discharge channels, which are the primary local habitat for all life stages. The Emerald Shiner prefers nearshore areas with substrate structure. Spawning and embryo-larval development occurs primarily around the armoured break wall and intake channel, and may also include portions of the discharge channel. The spawning and larval periods for both species extend from mid-April through May, although Emerald Shiner may spawn through August.

Golder (2007b, Table A3.1-1) found that modelled MWATs for Smallmouth Bass, Emerald Shiner and Lake Trout did not exceed MWAT criteria for spawning and larval development in any areas of suitable spawning habitat during the relevant timeframe. In April- June, only the discharge channels had modelled values marginally above MWAT criteria (i.e. at 27°C). In the winter period, relevant to Lake Trout, modelled values above MWAT criteria were found in the discharge channels, and at one lake location (N) near the PN U5-8 discharge with modelled values as high as 12°C; these locations do not represent Lake Trout habitat. Therefore, it was concluded that temperatures in the thermal plume are unlikely to have adverse effects on fish embryo-larval development.

Cooper (2013) evaluated lake temperatures in the vicinity of the PN U5-8 discharge using 2011-2012 data provided by OPG from thermal dataloggers placed on the substrate. Temperature results at locations in the thermal plume and in reference areas (Thickson Point and Bonnie Brae Point, 12 km west and 6 km east of Darlington Nuclear (DN), respectively) were compared to thermal criteria for 15 species and HQ values were calculated for relevant time periods for each species at each location. The thermal criteria relevant to fish embryo-larval periods are listed in Table 4.45 for five species that are VECs in the ERA.

Table 4.45: Thermal Criteria Relevant to Spawning and Embryo-Larval Development of Selected Fish Species (Cooper, 2013)

Lake Trout

Stage	MWAT (°C)	STDM (°C)
Spawning	9	
Egg		10
Larvae		

White Sucker

Stage	MWAT (°C)	STDM (°C)
Spawning	10	24.1
Egg		24.1
Larvae	28	30

Brown Bullhead

Stage	MWAT (°C)	STDM (°C)
Spawning	22.5	
Egg		26
Larvae		

Smallmouth Bass

Stage	MWAT (°C)	STDM (°C)
Spawning	17	
Egg		28.3
Larvae		

Walleye

Stage	MWAT (°C)	STDM (°C)
Spawning	8.5	
Egg		20
Larvae		

Notes:

MWAT = maximum weekly average temperature, STDM = short-term daily maximum temperature

Hazard quotients were calculated by taking the measured MWAT or STDM at each location, for the seasonal period relevant to each species, and dividing by the MWAT or STDM criterion.

Table 4.46 presents the HQ values for the selected species. Four had HQ values at least marginally above 1, indicative of potential adverse effects from the thermal plume. The HQ is shown for the highest temperature location in the plume area, and in the reference area. The HQs in the plume area are not substantially elevated relative to the reference area. Round Whitefish and Lake Trout had embryo-larval HQs above 1, but those for Lake Trout round to 1. In both cases, the HQs for reference areas were also above 1, and those in the plume area were only slightly higher.

Table 4.46: Thermal Hazard Quotients Relevant to Spawning and Embryo-Larval Development of Selected Fish Species in Lake Ontario near the PN U5-8 Discharge (Cooper, 2013)

Lake Trout	Plume B		Reference (BB)	
Stage	HQ _{MWAT}	HQ _{STDM}	HQ _{MWAT}	HQ _{STDM}
Spawning	2.33		2.33	
Egg		1.28		1.06
Larvae				

White Sucker	Plume B		Reference (BB)	
Stage	HQ _{MWAT}	HQ _{STDM}	HQ _{MWAT}	HQ _{STDM}
Spawning	1.69	0.79	1.93	0.86
Egg		0.9		0.92
Larvae	0.81	0.8	0.81	0.8

Brown Bullhead	Plume B		Reference (BB)	
Stage	HQ _{MWAT}	HQ _{STDM}	HQ _{MWAT}	HQ _{STDM}
Spawning	0.82			
Egg		0.73		
Larvae				

Smallmouth Bass	Plume B		Reference (BB)	
Stage	HQ _{MWAT}	HQ _{STDM}	HQ _{MWAT}	HQ _{STDM}
Spawning	1.08		1.14	
Egg		0.67		0.73
Larvae				

Walleye	Plume B		Reference (BB)	
Stage	HQ _{MWAT}	HQ _{STDM}	HQ _{MWAT}	HQ _{STDM}
Spawning	1.05		0.96	
Egg		0.89		0.91
Larvae				

Notes:

The HQ shown represents the highest temperature location in each area.
BB = Bonnie Braie Point reference location

4.4.3.1.1 Thermal Increments and Embryo-larval Survival of Round Whitefish

Water temperature on the Round Whitefish spawning beds was monitored by OPG using dataloggers installed over the 2009-2010, 2010-2011 and 2011-2012 embryo-larval incubation periods (OPG 2010e, 2012f, 2013d).

OPG (2017) evaluated the potential effect of lake water temperature in the thermal plume at PN and reference sites on the survival of Round Whitefish using the 2009-2010, 2010-2011 and 2011-2012 temperature data and a thermal survival model. The thermal survival model used a revised Hybrid Block 1 Model and the COG Block 3 Model, where Block 1 refers to the early incubation period of Round Whitefish embryos, and Block 3 refers to the late incubation period. As shown in Table 4.47, the estimated survival loss at the plume stations compared to the reference stations (Thickson Point and Bonnie Brae) was low: 0.80% in 2009-2010, 1.39% in 2010-2011, and 2.51% in 2011-2012. These values are all below the threshold no-effect level of 10% for survival loss of Round Whitefish embryos. However, in 2011-2012, a year with warmer winter water temperatures, the threshold no-effect level of 10% relative survival loss was exceeded at one station, P1 (10.76%).

The areal extent of the plume is provided in Figure 4.14. Contour lines depicting 5 and 10% relative survival loss (black) for the 1 December, 2011, spawning date are overlaid on the substrate map. The cobble substrate suitable for spawning is shown in dark red. Only a small fraction of the suitable habitat is adversely affected by the plume, i.e., 1.2% of the potential spawning habitat area for a 10% relative survival loss and 4% of the area for a 5% relative survival loss. Due to the limited spatial (1.2% of the potential spawning habitat area, Figure 4.14) and temporal effect at P1, the potential for reduced survival of embryos can be considered minor and not significant. Therefore, the thermal plume from PN is not having an adverse effect on Round Whitefish embryo survival and is not having an adverse effect on the local or regional Round Whitefish population, there being only one discrete genetic population of Round Whitefish spawning in the region (Wood et al. 2016).

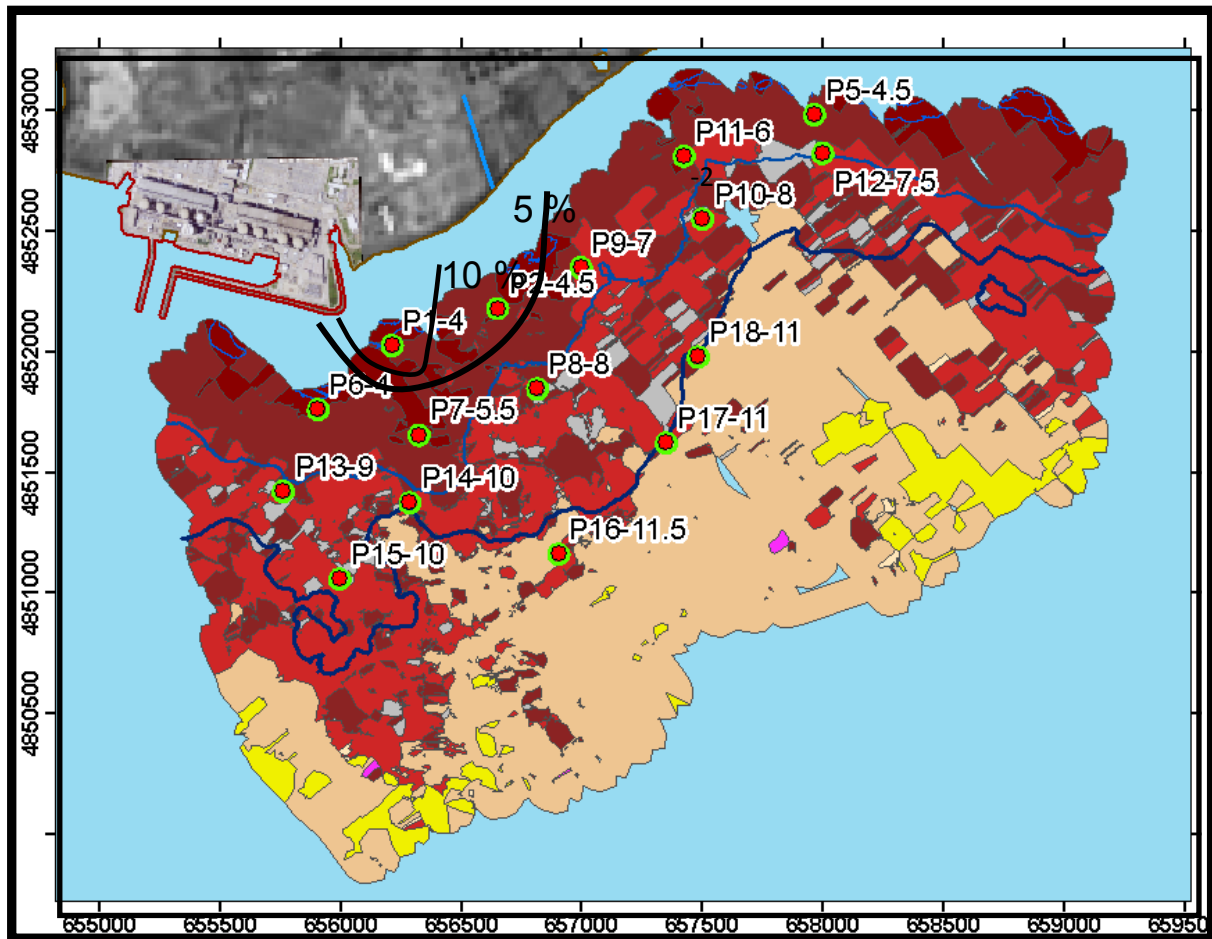

Figure 4.14: Estimated areal extent of potential changes in relative survival loss of Round Whitefish embryos at Pickering Nuclear based on substrate temperatures for a spawning date of 1 December, 2011

An average water temperature of 6°C during the spawning and egg incubation period has been adopted as a threshold effect level. Mean water temperature at all plume stations in 2009-2010, 2010-2011 and 2011-2012 were below the threshold effect level. Likewise, the mean temperature at each of the 16 individual stations in the PN thermal plume was below the threshold effect level of 6°C in each year (OPG, 2017). Further, investigation of the potential effects of pulse (short term) temperature increases revealed that maximum water temperature rarely exceeded 10°C (only for 1 hour at P6 in 2010-2011, for 7 hours at P1, and 1 hour at both Stations P2 and P6 in 2011-2012 over the winter period) (OPG 2017). These temperature increases above 10°C are of short duration compared to greater temperature exposures above 10°C for 6 hours per day over the incubation period where high survival was recorded in the Griffiths (1980) study. Therefore, based on the thermal survival model calculations and the mean water temperatures being below the thermal

effect level, the thermal plume from PN is not having an adverse effect on the development of Round Whitefish embryos.

Table 4.47: Predicted Round Whitefish Egg Survival based on the Revised Hybrid Model and Winter Temperature Data at All Plume Stations (OPG, 2017)

All plume stations included (2009-2010)						
	Block 1		Block 3		Block 1 + 3	
	Ref.	Plume	Ref.	Plume	Ref.	Plume
Mean temperature (°C)	2.28	3.45	4.06	4.18		
Embryo survival	99.10%	98.36%	98.70%	98.64%	97.81%	97.03%
Relative survival loss	0.75%		0.06%		0.80%	
All plume stations included (2010-2011)						
	Block 1		Block 3		Block 1 + 3	
	Ref.	Plume	Ref.	Plume	Ref.	Plume
Mean temperature (°C)	3.26	4.22	1.88	2.68		
Embryo survival	98.58%	97.35%	99.26%	99.12%	97.86%	96.50%
Relative survival loss	1.25%		0.14%		1.39%	
All plume stations included (2011-2012)						
	Block 1		Block 3		Block 1 + 3	
	Ref.	Plume	Ref.	Plume	Ref.	Plume
Mean temperature (°C)	4.67	5.20	3.18	3.94		
Embryo survival	96.45%	94.29%	99.02%	98.71%	95.47%	93.07%
Relative survival loss	2.24%		0.31%		2.51%	

Notes:

Block 1 is the early incubation period of Round Whitefish embryos, 30 days post-fertilization (December 1).
 Block 3 is the late incubation period of Round Whitefish embryos, 30 days prior to median hatch (based on degree days).

4.4.3.2 Thermal Plume Effects on Growth of Juveniles and Adults

The potential effects of the thermal plume on fish growth were evaluated in the Aquatic Environment TSD for the EA for the refurbishment and continued operation of the PN Units 5-8 (Golder, 2007b). The thermal regime as influenced by the existing plume was determined by numerical modelling which described the seasonal and spatial variation in water temperature. The modelled MWATs were compared to MWAT criteria representing an upper bound of temperature suitable for growth under chronic exposure conditions. MWAT criteria were defined for two warm water fish species (Smallmouth Bass and Emerald Shiner) and two cold water species (Round Whitefish and Lake Trout) (Golder, 2007b, Table A2.5-1). These species were selected based on local abundance and identified potential for thermal plume effects. While some other fish species (White Sucker, Walleye, Northern Pike) are common in the area, they are transient or do not have susceptible life history stages. The MWAT criteria for juveniles and adults are considered here (Table 4.48). Thermal effects on spawning and embryo-larval development are considered in Section 4.4.3.1.

Table 4.48: Thermal Criteria Relevant to Growth and Mortality of Selected Fish Species (Golder, 2007b)

Fish Species	Life Stage	Optimum Temp (°C)	Upper Lethal Temp (°C)	MWAT Criteria (°C)	Nearshore Timeframe
Smallmouth Bass	Adult	21	36	29, 33	all year
	Juvenile	28.5	35	29	all year
Round Whitefish	Adult	15	26.7	18.9	mid-Nov-Dec
	Juvenile	17, 18.5	26.7	20.2, 21.2	mid-Nov-Dec
Emerald Shiner	Adult	25	42	30	all year
	Juvenile	23	35	30	all year
Lake Trout	Adult	12	21.5	19.4	mid-Nov-Apr
	Juvenile	12	21.5	19.4	mid-Nov-Apr

The cold water species avoid the Lake Ontario nearshore during the summer period, and are thus not exposed to the thermal plume at this time. For example, Round Whitefish are potentially exposed from mid-November to early December and Lake Trout are potentially exposed from mid-November to April. Golder (2007b, Table A3.1-1) found that modelled MWATs did not exceed criteria for growth of juveniles and adults of Round Whitefish and Lake Trout at the time that they are present in the nearshore area.

The warm water species are potentially exposed to the thermal plume during the summer growth period when water temperatures are highest. The discharge and intake channels have been identified as the primary habitat areas for the Smallmouth Bass in the area. The modelled MWATs marginally exceeded the criteria for growth of juveniles and adults occasionally at one lake location near the PN U5-8 discharge over the July to September

period (e.g., up to 29.93°C vs criterion of 29°C for Smallmouth Bass) and only in the near surface water. Deeper water at the same location did not exceed the criterion. Residing mainly near the bottom, these fish would likely not be exposed to temperatures that are adverse for growth.

In the discharge channel, the maximum modelled MWATs were as high as 34°C over the July to September period, which exceeds the MWAT criteria for growth of juveniles and adults for both Smallmouth Bass (29°C) and Emerald Shiner (30°C). However, the average modelled MWAT over this period was 25°C, well below the MWAT criteria. The upper lethal temperatures for these species were not exceeded.

Algal growth events during the late summer and fall occasionally require the cooling water intake pumps to be shut off to clear the algae, which results in a slightly increased discharge temperature. Hourly temperature values for influent and effluent, and ΔT values, are routinely monitored, and daily average values are calculated for comparison to the ECA ΔT limit of +11°C. Based on results over the 2010 to 2015 period, only PN U5-8 experienced algae events with ΔT limit exceedance. The number of algal events per year has ranged from 1 to 7; and the events typically last 1 or 2 days. During these events, effluent temperature has usually increased by a few degrees, and the daily average temperature has occasionally exceeded the MWAT criterion for Smallmouth Bass (29°C). Weekly average temperatures during these events generally do not exceed the criterion.

In summary, algal events have the potential to slightly increase water temperatures in the discharge channel, and water temperatures near the surface in the lake near the discharge, for short periods of time. These brief and occasional changes in thermal regime due to algal events would not be expected to have any substantial effect on the suitability of nearshore waters for growth of the fish species that reside there at the time of these events.

As discussed in Section 4.4.3.1, Cooper (2013) evaluated lake temperatures in the vicinity of the PN U5-8 discharge using 2011-2012 data provided by OPG from thermal dataloggers placed on the substrate. Temperature results at locations in the thermal plume and in reference areas (Thickson Point and Bonnie Brae Point) were compared to thermal criteria for 15 fish species and HQ values were calculated for relevant time periods for each species at each location. The thermal criteria relevant to juvenile and adult stages are listed in Table 4.49 for five species that are VECs in the ERA.

Table 4.49: Thermal Criteria Relevant to Juvenile and Adult Stages of Selected Fish Species (Cooper, 2013)

Lake Trout

Stage	MWAT (°C)	STDM (°C)
Juvenile	19.4	21.5
Adult		23.5

White Sucker

Stage	MWAT (°C)	STDM (°C)
Juvenile	28	35.6
Adult	28	31.6

Walleye

Stage	MWAT (°C)	STDM (°C)
Juvenile	25	28.5
Adult	25	

Smallmouth Bass

Stage	MWAT (°C)	STDM (°C)
Juvenile	32.5	35
Adult	31	32

Brown Bullhead

Stage	MWAT (°C)	STDM (°C)
Juvenile	32	37
Adult		37.8

Notes:

MWAT=maximum weekly average temperature, STDM= short-term daily maximum temperature

HQs were calculated by taking the measured MWAT or STDM at each location, for the seasonal period relevant to each species, and dividing by the MWAT or STDM criterion.

Table 4.50 presents the HQ values for juvenile and adult stages for the selected species. The HQ is shown for the highest temperature location in the plume area, and in the reference area. The highest HQs were marginally above 1 in the plume for Lake Trout, and White Sucker, but were less than or equal to reference values for both species. Therefore, it is unlikely that there are any effects arising from the thermal plume in the lake for juvenile or adult stages of any fish species.

Table 4.50: Thermal Hazard Quotients Relevant to Juveniles and Adults of Selected Fish Species in Lake Ontario near the PN U5-8 Discharge (Cooper, 2013).

Lake Trout	Plume B		Reference (BB)	
Stage	HQ _{MWAT}	HQ _{STDM}	HQ _{MWAT}	HQ _{STDM}
Juvenile	1.16	1.11	1.16	1.11
Adult		1.02		1.02

White Sucker	Plume B		Reference (BB)	
Stage	HQ _{MWAT}	HQ _{STDM}	HQ _{MWAT}	HQ _{STDM}
Juvenile	0.81	0.67	0.81	0.67
Adult	0.81	0.76	0.81	0.76

Walleye	Plume B		Reference (BB)	
Stage	HQ _{MWAT}	HQ _{STDM}	HQ _{MWAT}	HQ _{STDM}
Juvenile	0.9	0.84	0.91	0.84
Adult	0.9		0.91	

Smallmouth Bass	Plume B		Reference (BB)	
Stage	HQ _{MWAT}	HQ _{STDM}	HQ _{MWAT}	HQ _{STDM}
Juvenile	0.69	0.68	0.7	0.68
Adult	0.73	0.75	0.73	0.75

Brown Bullhead	Plume B		Reference (BB)	
Stage	HQ _{MWAT}	HQ _{STDM}	HQ _{MWAT}	HQ _{STDM}
Juvenile	0.7	0.65		
Adult		0.63		

Notes:

The HQ shown represents the highest temperature location in each area.
BB = Bonnie Braie Point reference location

4.4.3.3 Thermal Plume Contribution to Winter Cold Shock

During an outage, thermal additions to receiving water can be rapidly curtailed, such that water temperature declines more rapidly than fish are able to acclimate to lower temperatures (Coutant, 1977). In this event, called cold shock, water temperature may fall below the lower lethal temperature, and fish mortality may occur. Cold shock can only occur during a full station outage. A full station outage is a rare event and usually only occurs every 10 years when a vacuum building outage is required. In theory, heat shock can also occur when water is rapidly warmed, but temperature rise during start-up seldom occurs at a sufficient rate to cause heat shock.

Fish are most susceptible to cold shock in the winter months (Wismer and Christie, 1987), whereas outages usually occur in spring and fall when demand for power is low. Fish are least susceptible to cold shock in spring and fall. Therefore, cold shock is not a likely occurrence during most outages.

SENES (2001) addressed the potential for cold shock at PN. From October 1999 to January 2001, at a monitoring location near PN U5-8 discharge, winter water temperatures were typically 10°C, or ambient 4°C with an increment of 6°C (SENES, 2001, Figures 8.2-2 and 8.2-4). Coutant (1977) indicates a lower lethal temperature of about 2°C at acclimation temperatures up to 14°C (SENES, 2001, Figure 8.1-1). Thus, a drop from the nearfield plume temperature of 10°C to an ambient temperature of 4°C would be unlikely to induce cold shock. However, the possibility of lower ambient temperatures in winter, and a drop below the lower lethal temperature during a winter outage, is acknowledged.

SENES (2001) notes that natural upwellings in the Lake Ontario nearshore can reduce nearshore water temperature by as much as 10°C in a few hours, resulting in natural cold shock events over a relatively large area. Given that a winter outage during a particularly cold period is a rare event, and that any cold shock effects of an outage would be localized near the plume outfall, such events must represent a small contribution to cold shock risk for fish populations.

4.4.4 Entrainment/Impingement

Fish impingement sampling was conducted at PN from September 2003 to September 2004. Fish egg/larvae entrainment sampling was conducted from mid-March through December 2006. These results were evaluated in 2007 and 2008 in terms population-relevant metrics, comparable to fishery statistics, as recommended in CSA N288.6-12. Subsequently, in October 2008, OPG was ordered by the CNSC to reduce fish impingement at the Pickering station by 80%, and to reduce fish entrainment by 60%, relative to the baseline year (2003/04). In order to reduce impingement, OPG installed a fish diversion system (FDS), in October 2009. No reasonable technological solution is available to reduce entrainment by 60% (OPG, 2012h), but these losses are more than offset by operation of the FDS and by OPG support for projects to create Northern Pike

spawning and nursery habitat (OPG, 2012h), and by OPG participation in the Bring Back the Salmon Program (Lake Ontario Atlantic Salmon Restoration Program, 2011). The latter program is focused on restoration of Atlantic Salmon in Lake Ontario; it includes fish production and stocking, water quality and habitat enhancement, outreach and education, and research and monitoring components.

In 2016, OPG notified DFO and CNSC of their intention to submit an application for a Fisheries Act authorization for PN operational activities associated with the continual intake of cooling water from Lake Ontario. As part of the application, OPG will update the estimates of equivalent loss of fish (Age-1 equivalent and production foregone) considering impingement data after installation of the FDS. For the purpose of meeting the requirements of CSA N288.6-12, section 4.4.4.1 provides an evaluation of impingement and entrainment prior to installation of the FDS.

4.4.4.1 Evaluation of Impingement in 2003/04 and Entrainment 2006

Fish impingement occurs at the combined cooling water intake for PN. Fish were collected on a regular basis from the traveling screen bins in 2003/04 (Golder, 2007g). The most abundant species, in decreasing order of relative abundance, were Alewife (42.9%), Threespine Stickleback (37.9%), Emerald Shiner (9.1%), Rainbow Smelt (3.4%) and Brown Bullhead (2.7%). A total of 36 species were represented in the collections.

Actual counts of each species were scaled up for times not sampled to obtain annual numbers. The annual numbers were scaled up to account for less than full design flow at the time of sampling. Then juvenile numbers were scaled down to account for natural rates of survival to age 1. Impingement losses were expressed as age 1 equivalents. Finally, the biomass production foregone as a result of impingement losses was calculated. The results as presented by Golder (2007b) are summarized in the fish impingement row of Table 4.51.

Table 4.51: Entrainment/Impingement at PN before the FDS (Golder, 2007g)

	Actual Counts	Estimated Annual Loss ^c	Annual Loss for Max Flow ^d	Age-1 Equivalents ^e	Production Foregone (kg) ^f
Fish Impingement	380,590	706,941	831,505	561,484	5,695.6 ^b
Larval Entrainment	53	11,209,435	11,388,876	455,373 ^a	163.3 ^a
Egg Entrainment	347	50,575,743	51,994,686	-	-

Notes:

^a combined egg and larvae contributions

^b includes 3,251.7 kg forage fish, equivalent to 81.9 kg sport fish

^c estimated annual loss accounts for times not sampled;

^d scaled up to represent full design flow

^e numbers scaled down to account for natural survival of younger fish to Age-1

^f represents lost production of fish biomass due to fish entrainment/impingement at PN

Fish eggs and larvae that pass through the screens are entrained with the cooling water. They were sampled in 2006 from March to December (Golder, 2007g) through a hose from the intake, approximately 50 m from the west intake groyne and 1.5 m above the substrate. The species represented, in decreasing order of relative abundance were Common Carp (48.36%), Alewife (34.91%), Round Goby (16.51%) and Freshwater Drum (0.22%). A total of four species were represented.

Actual counts of eggs and larvae were adjusted for times not sampled to obtain annual numbers, and these were scaled up to represent full design flow conditions as described above. The combined egg and larval entrainment losses were expressed as age-1 equivalents, and the biomass production foregone as a result of these losses was calculated. The results as presented by Golder (2007b) are shown in the bottom two rows of Table 4.51.

SENES (2009) analyzed the Golder (2007g) E/I data independently, using slightly different life history assumptions and more realistic methods, focusing on the 15 most common species. Most importantly, while Golder assumed all adult fish were age-1, SENES used their likely ages based on length and weight data. Their results are shown in Table 4.52.

Table 4.52: Entrainment/Impingement at PN before the FDS (SENES, 2009)

Fish Species	Annual Loss for Max Flow	Age-1 Equivalents	Production Foregone (kg)	Annual Loss Represents (Golder, 2007g)
Alewife	356,722	295,632	5,557	0.2% of L. Ontario population
Brown Bullhead	22,483	11,455	1,184	1% of L. Ontario commercial harvest
Brown Trout	604	696	270	2 % of L. Ontario angler harvest
Chinook Salmon	182	289	51	0.4 % of L. Ontario angler harvest
Coho Salmon	9	14	2	2% of L. Ontario angler harvest
Emerald Shiner	75,481	90,713	83	3 kg of sport fish production
Lake Trout	149	80	11	0.1% of L. Ontario angler harvest
Northern Pike	144	146	747	1% of L. Ontario commercial harvest ¹
Rainbow Smelt	28,078	22,920	830	0.01% of L. Ontario population
Round Whitefish	133	189	40	0.14 kg of sport fish production
Smallmouth Bass	180	164	28	0.13% of L. Ontario angler harvest
Threespine Stickleback	314,773	173,956	154	7 kg of sport fish production
Walleye	1,263	492	350	0.2-0,3% of L. Ontario angler harvest

Fish Species	Annual Loss for Max Flow	Age-1 Equivalentents	Production Foregone (kg)	Annual Loss Represents (Golder, 2007g)
White Sucker	2,431	1,754	121	13 kg of sport fish production
Yellow Perch	832	891	5	0.2% of L. Ontario angler harvest
Total	803,464	599,391	9,434	

¹ Northern pike commercial harvest from OCFA (2016).

The numbers of fish lost to entrainment and impingement represent a very small fraction of lake-wide populations, as discussed by Golder (2007b). For example, the Alewife losses represent less than 0.2 % of the lake-wide population. The Brown Bullhead losses represent 1% of the commercial harvest in Lake Ontario. The losses of Emerald Shiner represent an amount that would produce approximately 3 kg of sport fish biomass. The Lake Trout losses represent 0.1% of the catch by fishing boats in Lake Ontario. The Northern Pike losses, at an average weight of 1.76 kg, represent 1% of the commercial harvest from Canadian waters of Lake Ontario (18,664 kg, OCFA, 2016). The losses of Round Whitefish represent an amount that would produce approximately 0.14 kg of sport fish biomass. The Smallmouth Bass losses represent 0.13% of the angler harvest in eastern Lake Ontario. The losses of Threespine Stickleback, represent an amount that would produce approximately 7 kg of sport fish biomass. The Walleye losses represent 0.2 to 0.3% of the amount harvested annually by anglers in Lake Ontario. It is unlikely that the losses at the Pickering station have any appreciable effect on the success of Lake Ontario fish populations.

4.4.4.2 Impingement Reduced by the Fish Diversion Structure

A FDS consisting of a barrier net around the Pickering cooling water intake was installed in October, 2009. It is maintained in place from April through November. It is removed during the winter months because water conditions are unsafe for divers who must maintain the nets free of algae and other debris.

Studies of FDS performance were undertaken in 2010 through 2015. Performance was evaluated in terms of the reduction in impinged fish biomass, on an annual basis, relative to the baseline year (2003/04) (OPG, 2011i, 2012h, 2013e, 2014b, 2015c, 2016b). Table 4.53 summarizes the results.

Table 4.53: Impinged Biomass and Percent Reduction in 2010 and 2012 (OPG, 2013e, 2014b, 2015c, 2016b)

Fish Species	2003/04	2010	2011	2012	2013	2014	2015	2010	2011	2012	2013	2014	2015
	Biomass (kg)	Biomass (kg)	Biomass (kg)	Biomass (kg)	Biomass (kg)	Biomass (kg)	Biomass (kg)	Reduction (%)	Reduction (%)	Reduction (%)	Reduction (%)	Reduction (%)	Reduction (%)
Freshwater Drum	4803.4	128.9	204.1	95.1	76.0	64.0	27.0	97.3	95.8	98.0	98.4	98.7	99.4
Brown Bullhead	3287.2	48.7	46.0	11.4	70.0	34.0	26.0	98.5	98.6	99.7	97.9	99.0	99.2
Alewife	3134.6	2591.9	1912.1	165.3	442.0	747.0	6382.0	17.3	39.0	94.7	85.9	76.2	-103.6
Carp	2621.7	347.2	462.5	263.0	365.0	949.0	507.0	86.8	82.4	90.0	86.1	63.8	80.7
Gizzard Shad	1702.0	393.1	327.2	528.2	834.0	1189.0	721.0	76.9	80.8	69.0	51.0	30.1	57.6
Salmonids	717.8	260.5	237.4	155.3	283.0	500.0	553.0	63.7	66.9	78.4	60.6	30.3	23.0
Walleye	617.8	27.8	0.0	3.5	29.0	0.0	0.0	95.5	100.0	99.4	95.3	100.0	100.0
White Sucker	608.3	77.9	94.9	33.5	93.0	56.0	84.0	87.2	84.4	94.5	84.7	90.8	86.2
Threespine Stickleback	279.0	0.6	0.3	0.2	4.0	5.0	0.0	99.8	99.9	99.9	98.6	98.2	100.0
Emerald Shiner	136.0	23.7	4.1	7.5	6.0	1.0	1.0	82.6	97.0	94.5	95.6	99.3	99.3
Smallmouth Bass	84.2	11.2	17.8	8.9	8.0	26.0	10.0	86.7	78.9	89.4	90.5	69.1	88.1
Northern Pike	66.9	51.2	120.4	132.9	188.0	112.0	70.0	23.5	-79.9	-98.7	-181.0	-67.4	-4.6
Rainbow Smelt	41.7	124.5	132.5	4.7	96.0	3.0	0.0	-198.6	-217.8	88.7	-130.2	92.8	100.0
American Eel	38.5	0.5	12.3	53.6	13.0	43.0	63.0	98.7	68.1	-39.2	66.2	-11.7	-63.6
Yellow Perch	16.6	15.3	18.1	23.2	30.0	50.0	5.0	7.8	-8.8	-39.8	-80.7	-201.2	69.9
Sea Lamprey	4.4	36.1	14.7	7.2	24.0	3.0	1.0	-714.2	-231.8	-63.6	-445.5	31.8	77.3
Round Goby	0.0	287.5	155.6	120.8	167.0	82.0	25.0	NA	NA	NA	NA	NA	NA
Total Biomass	18,214.0	4616.5	3782.0	1706.0	2926.0	3953.0	8553.0	74.7	79.2	90.6	83.9	78.3	53.0
mg / m ³ Flow	4.35	0.95	0.84	0.35	0.60	0.82	2.24	78.8	80.6	92.0	86.2	81.1	48.5

For many fish species there have been substantial reductions in the biomass lost to impingement since the installation of the FDS. For a few species, such as Rainbow Smelt, the biomass lost to impingement has increased in some years relative to the baseline year (2003/04). Both Rainbow Smelt and Alewife have been increasing in abundance in the lake (GLFC, 2010 and 2011). The Round Goby was not impinged in the baseline year, thus a reduction in goby impingement cannot be calculated. This is an invasive species that has recently extended its range into the Pickering area and may still be undergoing rapid population growth here.

In order to estimate a percent reduction in fish impingement that is not influenced by the arbitrary selection of a baseline year, OPG conducted hydroacoustic and gill netting surveys to estimate fish abundance inside and outside the FDS net face. Using these data it was possible to predict the fish biomass that would have been impinged in each year if the FDS was not deployed. The impinged biomass in 2010 and 2011 was then compared to that which would have been impinged in the absence of the FDS. Using this method, the reduction in impinged biomass was estimated at 88% in 2010 and 85% in 2011 (OPG, 2012h). These results suggest greater FDS efficiency than that illustrated in Table 4.53.

Overall, biomass lost to impingement was reduced relative to baseline by 75 to 91% on an annual basis over the 2010 to 2014 period (average 81%). Biomass per unit of CCW flow was reduced by 79 to 92% on an annual basis over the same period (average 84%). These reductions in impinged biomass are considered to meet or exceed the 80% reduction target.

In 2015, the biomass lost was reduced only 53% on an annual basis (OPG, 2016b). This was due to a single impingement event on 28 May, 2015, in which large numbers of alewife were impinged. This event occurred during the installation of the FDS, which is installed annually after the ice melts in Lake Ontario. During the first phase of affixing two pieces, the FDS came apart, allowing the fish to be impinged. Except for this one event, impingement was typical of that observed over the 2010 to 2014 period, at 0.67 mg/m³ of flow.

The FDS only reduces the impingement component of fish losses at the Pickering cooling water intake. The entrainment losses will be similar to those reported prior to FDS installation. The impact of entrainment losses, in terms of production foregone, is an order of magnitude less than the impact of impingement losses (Table 4.52).

The combined losses prior to the FDS installation, considering adult equivalents and production foregone, were found to be very small relative to commercial and recreational harvests (Golder, 2007g; SENES, 2008). Since the major part of this loss has been reduced by approximately 80%, losses that were of little ecological consequence before the FDS will be smaller and even less consequential now that the FDS is in operation. Since OPG is seeking an authorization under the Fisheries Act, any further mitigation would be determined as a result of the authorization process.

4.4.4.2.1 Northern Pike

The loss of Northern Pike has not been reduced overall by the FDS, likely because this species is prevalent in the winter when the FDS is not in place. OPG has participated with the TRCA in tagging Northern Pike captured in the Pickering area nearshore, Frenchman's Bay and Duffins Creek Marsh (OPG, 2016b). Over the 2010 – 2015 period only one tagged fish has been impinged. This result suggests that impinged pike represent a small fraction of the local population, consistent with the Golder (2007b) finding (Section 4.4.4.1) that impinged pike represent a small fraction of the commercial harvest in the Canadian waters of Lake Ontario.

4.4.4.2.2 American Eel

The American Eel is listed as endangered under Ontario's Endangered Species Act. It declined through the 1980s to a low point in the late 1990s. It has recovered slightly since then, implementation of fish passage programs, and with closure of all commercial and recreational fishing in Ontario in 2004. OPG has operated the Saunders eel ladder at the Moses-Saunders dam on the St. Lawrence River since 2007, while the New York Power Authority operates a ladder on the American side. In 2015, the combined passage of eels was 28,215 (Ontario MNRF, 2016b). The annualized estimate of 79 eels impinged at PN in 2015 represents 0.3% of this number. By operating the Saunders eel ladder on the St. Lawrence, and the FDS at PN, OPG attempts to keep eel mortality as low as possible.

4.4.5 Uncertainties in the Risk Characterization

There are uncertainties associated with the components contributing to the overall risk assessment. This includes receptor exposure factors, such as transfer factors, intake rates and bioaccumulation factors, partition coefficients, dose coefficients and averaging assumptions (uncertainties discussed in Section 4.2.6), as well as benchmarks values used to determine risk of potential effects (uncertainties discussed in Section 4.3.4).

Overall, considering uncertainties in the exposure assessments and the benchmark values, it is reasonable to consider that HQs above 1 for a COPC, receptor and location are indicative of a potential for adverse effects. However it does not necessarily imply adverse effects. In some cases, field studies may be appropriate to clarify whether effects are occurring.

A probabilistic risk assessment to quantify uncertainty in the risk estimate has not been performed and is not considered necessary, since it is not likely to provide a better basis for risk management/decision making. According to CSA N288.6-12 (CSA, 2012), a qualitative or semi-quantitative evaluation of uncertainty is considered sufficient for evaluation of uncertainty.

5.0 CONCLUSIONS AND RECOMMENDATIONS

5.1 Conclusions

5.1.1 Conclusions of Human Health Risk Assessment (HHRA)

5.1.1.1 Non-Radiological HHRA

Potential risks to human receptors were characterized quantitatively in terms of Hazard Quotients (HQs) for non-carcinogens (morpholine) and Incremental Lifetime Cancer Risks (ILCRs) for potential carcinogens (hydrazine).

No risks to the urban resident, commercial/industrial worker, and correctional institution resident are expected due to exposure to modelled maximum and mean morpholine concentrations in drinking water - all HQs were less than the acceptable risk level of 0.2. With respect to the sport fisher, risks from morpholine through fish ingestion are below the acceptable risk level of 0.2 for non-cancer risk, indicating that no increased risk from fish ingestion is expected. The fish tissue concentration was estimated based on measured morpholine concentrations in the PN outfalls, and an assumed BAF for morpholine.

Risks from modelled hydrazine for the urban resident, correctional institution resident and industrial/commercial worker through water ingestion (Ajax WSP), are below the acceptable cancer risk level of 10^{-6} for both maximum and mean modelled hydrazine concentrations.

Exposure to the mean hydrazine concentration for the sport fisher through fish ingestion is below the acceptable cancer risk level of 10^{-6} . Since fish are mobile, exposure to the mean hydrazine concentration is more realistic than exposure to the maximum. The maximum would be above the acceptable cancer risk level of 10^{-6} . The maximum risk estimate is conservative. The fish tissue concentration was estimated based on measured hydrazine concentrations in the PN outfalls, and an assumed BAF for hydrazine.

The estimated risks to the urban resident and the commercial/industrial worker from inhalation of hydrazine (ILCRs) are below the acceptable cancer risk level of 10^{-6} . The risk estimates to the Urban Resident and Correctional Institution were $1.34\text{E-}07$ and $1.01\text{E-}07$, respectively. These risk estimates are based on updated modelling results for hydrazine in air using AERMOD (OPG, 2015e). The modelling results represent a worst-case hydrazine emissions scenario, but reduce some of the conservatism used in the 2014 ERA for the hydrazine assessment. The farm and dairy farm receptors were outside of the AERMOD modelling boundary, but are bound by the other human receptors evaluated.

In the 2014 ERA, the air concentrations at receptor locations were estimated using the dispersion factors used for the derived release limits and annual EMP dose calculations.

Risks at all receptor locations assessed due to inhalation of hydrazine are considered acceptable.

5.1.1.2 Radiological HHRA

For exposure of human receptors to radiological COPCs, the relevant exposure pathways and human receptors (critical groups) were those presented in the annual OPG EMP reports. Radiological dose calculations followed the methodology outlined in CSA N288.1-14. Table 5.1 presents a summary of the maximum dose to the critical group from 2011 to 2015. The annual dose during this five year period ranged from 0.9 to 1.2 μSv and the critical group was the urban resident (adult). The dominant pathways and radionuclides that contribute significantly to the total dose are inhalation of tritium and external exposure to noble gases.

Over the five year period (2011-2015), the public dose estimates for the critical group (urban resident) are approximately 0.1% of the regulatory public dose limit of 1 mSv/a and approximately 0.1% of the Canadian background radiation. Since the critical group receives the highest dose from PN, the demonstration that they are protected implies that other receptor groups near PN are also protected.

The Sport Fisher may receive a maximum dose up to 0.14 $\mu\text{Sv/a}$ from exposure to the PWMF (Phase I and Phase II) at full capacity. The dose to the Sport Fisher from existing PN operations is approximately 0.3 $\mu\text{Sv/a}$ (OPG, 2012d); therefore the total dose from PN operations and the PWMF may be up to 0.44 $\mu\text{Sv/a}$; however, this is still a small fraction of the regulatory public dose limit.

Facility releases are considered to be adequately controlled, and further optimization of PN operations is not required. Nevertheless, the ALARA principle is applied at PN to reduce emissions as much as is reasonably possible.

Since the dose estimates are a small fraction of the regulatory public dose limit and natural background exposure, no discernable health effects are anticipated due to exposure of potential groups to radioactive releases from PN.

Table 5.1: Summary of Annual Dose to Critical Group from 2011 to 2015

Year	Critical Group	Effective Dose (μSv)	Percentage of Regulatory Limit (%)	Percentage of Canadian Background Radiation (%)
2011	Urban Resident (adult, 10 year old child)	0.9	0.1	0.1
2012	Urban Resident (adult)	1.1	0.1	0.1
2013	Urban Resident (adult)	1.1	0.1	0.1
2014	Urban Resident (adult)	1.2	0.1	0.1
2015	Urban Resident (adult)	1.2	0.1	0.1

5.1.1.3 Noise Effects

The Acoustic Assessment Report (OPG, 2011c) prepared for PN demonstrates that PN operates in compliance with applicable MOECC noise limits. The 2011 Acoustic Assessment Report was subsequently reviewed and approved by the MOECC. In issuing the ECA for PN (OPG, 2015f), the MOECC verified that the findings of the Acoustic Assessment Report adequately demonstrate that PN does not cause a substantial noise impact at the identified PORs.

Although there are periods of recorded maximum sound levels above the MOECC NPC 300 Class 1 and Class 2 sound level limits, based on site observations these are unlikely to be directly associated with PN activities. These elevated sound levels are likely the result of localized events such as road traffic or human activity in the vicinity of the noise monitoring locations. It is common for noise levels in populated urban areas, such as near the PN site, to occasionally exceed the applicable prescribed sound level limit. As these occasional periods of elevated sound levels are not likely associated with PN activities, it is not expected that noise from PN activities is having a direct adverse effect on human receptors near the PN site.

5.1.2 Results of Ecological Risk Assessment (EcoRA)

5.1.2.1 Non-radiological EcoRA

The potential for ecological effects was assessed by comparing exposure levels to toxicological benchmarks, and characterized quantitatively in terms of Hazard Quotients (HQs). A HQ greater than 1 indicates a need to more closely assess the risk to the concerned VEC.

Outfall

Maximum and mean measured concentrations of hydrazine, morpholine, and total residual chlorine in the outfall did not exceed their respective benchmarks for the receptors of interest.

Based on estimated maximum copper concentrations in water near the PN outfall, the fish and benthic invertebrate benchmarks were exceeded; therefore the risk (HQ) was above the acceptable risk level of 1. Based on mean copper concentrations in water near the PN outfall, the risk level for fish and benthic invertebrates was acceptable. Since fish swim around, exposure to the mean concentration is more likely. Although a few benthic invertebrates may be exposed to these maximum measured concentrations, the community as a whole is not expected to be affected.

Based on estimated maximum copper concentrations in sediment near the PN outfall, the sediment benchmark for copper was exceeded; therefore the risk (HQ) was marginally above the acceptable risk level of 1 for benthic invertebrates. The estimated maximum

copper concentration in sediment is based on the maximum measured copper concentration in lake surface water with a sediment partition coefficient (K_d) applied; therefore, there is uncertainty around the sediment concentration, especially since sediment near the PN outfall is transient due to strong water currents in the outfall. Based on measured mean copper concentrations in water near the PN outfall, the estimated sediment concentration is below the sediment benchmark for copper; therefore, effects are not expected to the benthic invertebrate community. Additionally, there is uncertainty surrounding this risk as sediment in Lake Ontario is transient, and the invertebrate community is mainly epifaunal. It is unlikely that benthic invertebrates are at risk from PN operations because risks were not identified for benthic invertebrates exposed to copper via the surface water pathway.

The American Eel is identified as a species at risk; therefore the assessment endpoint is the health of the individual. As discussed above the fish benchmark was exceeded in the outfall for maximum measured water concentrations of copper. However, based on mean measured water concentrations the fish benchmark was not exceeded for copper. Since fish swim around a wider area, the HQs for mean water concentrations are more representative than maximum concentrations. As such, the American Eel is likely not at risk from any COPCs arising from PN operations.

Overall, the risk to fish at the outfall is low, and fish are not expected to experience any adverse effects due to PN operations.

Frenchman's Bay

Maximum and mean measured concentrations of morpholine, total residual chlorine, and sodium at Frenchman's Bay did not exceed the benchmarks for any of the aquatic biota identified at Frenchman's Bay.

Maximum and mean modelled concentrations of hydrazine at Frenchman's Bay did not exceed the benchmark for any of the aquatic biota identified at Frenchman's Bay. The benchmark used in the 2014 ERA (EcoMetrix, 2014) was an algal EC_{50} from the data set used to derive the Federal Water Quality Guideline (a 72-hour EC_{50} of 0.012 mg/L for algal growth, converted to a chronic value (1.2 $\mu\text{g/L}$). However, in this assessment, the aquatic plant benchmark used was the FEQG of 2.6 $\mu\text{g/L}$, since this guideline value is considered protective for all aquatic life (EC, 2013). Maximum concentrations are based on measured lake water data from 2014 from the vicinity of the PN outfalls (EcoMetrix, 2015) with a dilution factor of 9 to Frenchman's Bay applied.

There were no toxicity data for hydrazine for birds, as discussed in Section 4.3.1; therefore risks were not calculated for hydrazine to birds. Hydrazine is not expected to be of concern for birds due to the low risk of food chain bioaccumulation.

The maximum measured copper concentration in water at Frenchman's Bay is 2.1 $\mu\text{g/L}$, which marginally exceeds the aquatic plant benchmark of 2 $\mu\text{g/L}$. Measured copper

concentrations in water at Frenchman's Bay range from 1.4 to 2.1 µg/L. Based on maximum and mean measured copper concentrations in sediment in Frenchman's Bay, the sediment benchmarks were exceeded; therefore the HQ for benthic invertebrates in Frenchman's Bay marginally exceeded the acceptable risk level of 1. Although, the acceptable risk level of 1 for copper was exceeded for benthic invertebrates based on measured sediment concentrations, the contribution from PN operations to the copper concentration in water (and then partitioning to the sediment) at Frenchman's Bay is low ranging from 9% to 11% for copper (see Appendix E, Table E.9).

The maximum measured iron concentration in water at Frenchman's Bay exceeded the benthic invertebrate benchmark of 300 µg/L; however, the mean measured iron concentration in water at Frenchman's Bay was below the benthic invertebrate benchmark. Although a few benthic invertebrates may be exposed to these maximum measured concentrations, the community as a whole is not expected to be affected. Additionally, the maximum and mean measured iron concentrations in sediment at Frenchman's Bay did not exceed the sediment benchmarks for benthic invertebrates.

The HQs for aluminum for the muskrat; for aluminum and iron for the Bufflehead, and for iron for the Trumpeter Swan, Common Tern, and Ring-billed Gull exceeded the acceptable risk level of 1. With the exception of the Common Tern, the acceptable risk level was exceeded when receptors were exposed to both the maximum and mean measured water and sediment concentrations. Many of these receptors would not reside at Frenchman's Bay exclusively; therefore the HQs presented are conservative. Additionally, as discussed in Appendix E, exceedances of toxicity benchmarks are not uncharacteristic for an area such as Frenchman's Bay that is highly influenced by urban runoff. PN operations contribute a small proportion of the overall risk to aquatic receptors at Frenchman's Bay. The percent contribution from PN ranges from 0.3% to 22% over all COPCs (see Appendix E).

Least Bittern was identified as a species at risk on the PN site; therefore the assessment endpoint is the health of the individual. The representative species in this ERA is the Common Tern. As discussed above, the HQ for the Common Tern exceeded the acceptable risk level of 1 for maximum concentrations of iron. However, based on mean concentrations the HQ for the Common Tern did not exceed the acceptable risk level of 1. Since the Common Tern is mobile, mean exposure is more representative than maximum exposure. As such, the Least Bittern (represented by the Common Tern) is likely not at risk from iron exposure in Frenchman's Bay.

Pickering Nuclear Site

In general, soils on site that exceed benchmark concentrations are localized, suggesting the influence of past industrial operations rather than deposition from atmospheric sources. As such, COPC accumulation in soil over time is not expected. The soil sampling program focused on areas of previously identified contamination. Although, soil sampling only

occurred in areas identified as potential habitat, many of these areas on the PN site are not likely to be frequented by the selected VECs since they are near PN operations and not in highly vegetated areas.

The HQs for copper for the meadow vole; for copper, lead and zinc for the Red-winged Blackbird; and for lead and zinc for Red-tailed Hawk, exceeded the acceptable risk level of 1 when exposure to maximum concentrations was assumed. However, these receptors, with the exception of the meadow vole, are mobile and are unlikely to be exposed to the maximum concentrations for the entire year. There are no exceedances for mammals or birds exposed to average concentrations in soil, therefore adverse effects are not expected. The higher HQ value for copper for the Meadow Vole is driven by maximum modelled concentrations in terrestrial plants. The maximum copper concentration in the plant is localized to one sampling location (Site 14 SS5, see Figure 4.5). Therefore any effects on the meadow vole due to copper intake are limited to one area. Although localized effects to individual VECs may occur, the populations on the site as a whole are not expected to be affected.

The higher HQ value for zinc for the Red-winged Blackbird is driven by maximum concentrations in earthworms. Although the Red-winged Blackbird primarily eats insects, for this assessment the earthworm was used as a surrogate for all insects and invertebrates, which is likely conservative, since earthworms generally have higher contaminant concentrations than adult (flying) insects. Additionally, the Red-winged Blackbird is mobile; therefore exposure to average concentrations in soil is more likely. The HQ for zinc based on mean concentrations was below the acceptable risk level of 1; therefore, adverse effects are not expected.

Barn Swallow is identified as species at risk observed on the PN site; therefore the assessment endpoint is the health of the individual. The representative species in this ERA is the Red-winged Blackbird. As discussed above, HQs for the Red-winged Blackbird exceeded the acceptable risk level of 1 for maximum concentrations of copper, lead, and zinc. However, based on mean concentrations, HQs for copper, lead, and zinc did not exceed the acceptable risk level of 1. Since birds are mobile, mean exposure is more representative than maximum exposure. As such, the Barn Swallow is likely not at risk from PN operations.

Copper (maximum), zinc (maximum and mean), and petroleum hydrocarbon F4 (maximum) exposure concentrations exceeded benchmark values for earthworms. Although localized effects to individual earthworms may occur, the earthworm community on the site as a whole are not expected to be affected.

Maximum soil concentrations of arsenic, copper, zinc, and petroleum hydrocarbon F4 exceeded benchmark values for terrestrial plants. Mean soil concentrations of zinc also exceeded the benchmark value for terrestrial plants. The potential effects on plants due to exposure to arsenic, copper, and petroleum hydrocarbon F4 are expected to be limited to

small areas at the PN site. The toxicological benchmarks for these COPCs were exceeded at only 1 out of the 8 sampling locations at the PN site. Arsenic, copper, and petroleum hydrocarbon F4 benchmarks were exceeded at Site 14 SS5 (East Site - ditch north of the east site warehouse, see Figure 4.5). The zinc benchmarks were exceeded at GMS-28, GMS-31, Site 14 SS3 (2 locations), Site 14 SS5 (2 locations), and Site 14 SS6, as shown on Figure 4.5. Although localized effects to individual terrestrial plants may occur, the plant populations on the site as a whole are not expected to be affected.

Butternuts are identified as a species at risk; therefore, the assessment endpoint is the health of the individual. The representative species in this ERA is Red Ash (terrestrial plant). While individual plants may be exposed to concentrations above the soil benchmark, there are no trees in the areas on the PN site where soil concentrations were elevated, therefore, Butternut is not at risk in the localized areas of benchmark exceedance.

HQs for exposure of terrestrial mammals and birds to petroleum hydrocarbon F4 were not calculated. Petroleum hydrocarbon F4 is not a toxicological concern for mammals and birds (CCME, 2008).

East Landfill

The maximum sulphate concentration observed in Ditch 6 (the final surface water discharge point from the East Landfill to Lake Ontario located southeast of the landfill) was 328 mg/L, which exceeds the benchmark of 100 mg/L from the BC MOE. However, in April 2013 the BC MOE published an update to the sulphate water quality guideline based on a number of toxicity studies linking sulphate toxicity to water hardness. The revised BC guideline states that if natural hardness is greater than 250 mg/L site-specific toxicity testing on several species should be conducted, since the combination of high water hardness and sulphate levels may cause osmotic stress on the organism, likely related to high levels of total dissolved solids. The highest hardness level observed on site was 752 mg/L in 2010 from Ditch 6, with a sulphate concentration of 328 mg/L. Although there is uncertainty in the sulphate benchmark at hardness levels above 250 mg/L, the observed sulphate concentration in Ditch 6 is well below the LC₂₀ for trout of 857 mg/L at a hardness of 250 mg/L (BC MOE, 2013) as well as the LC₂₅ for *C. dubia* of 425 mg/L at a hardness of 320 mg/L (Elphick et al., 2011). The maximum sulphate in Ditch 6 is below these effect levels as well as below the sulphate guideline at the maximum hardness. Based on these observations, sulphate levels in Ditch 6 are not likely of concern.

5.1.2.2 Radiological EcoRA

Radiation dose benchmarks of 400 µGy/h (9.6 mGy/d) and 100 µGy/h (2.4 mGy/d) (UNSCEAR, 2008) were selected for the assessment of effects on aquatic biota and terrestrial biota, respectively, as recommended in the CSA N288.6-12 standard (CSA, 2012).

Outfall

There were no exceedances of the radiation dose benchmarks for the aquatic biota at the outfall location including fish, benthic invertebrates, and Ring-billed Gull.

Frenchman's Bay

There were no exceedances of the radiation dose benchmarks for any aquatic receptors at Frenchman's Bay.

Pickering Nuclear Site

There were no exceedances of the radiation dose benchmark for terrestrial biota on the PN site including earthworms, terrestrial plants, Meadow Vole, Red-winged Blackbird, Red Fox, and Red-tailed Hawk.

The 2014 ERA concluded that the total radiological dose benchmark was exceeded by the earthworm and Red-winged Blackbird based on the maximum tritium concentration in site soil. The exceedance was based on localized, elevated tritium concentrations in soil close to the reactor buildings. As discussed in Section 4.1.3.3, updated soil data were collected in 2015. To inform the baseline sampling program a site inspection was performed to focus the program on areas with vegetation or organic soil cover. Based on the site inspection, the area near PN U1 and U2 was removed from the soil monitoring program as this is a paved area without suitable habitat for terrestrial receptors. As a result, the dose and risk results for this current ERA provide a more realistic assessment of existing conditions.

Pickering Waste Management Facility

The maximum dose rate to any ecological VEC residing in close proximity to the PVMF could be up to 0.012 mGy/d; lower than the 2.4 mGy/d radiation benchmark for terrestrial biota. The dose also remains below the radiation benchmark if the maximum dose from the PVMF is combined with the dose to ecological VECs from being exposed to radionuclides through other existing PN operations (Table 4.40).

5.1.2.3 Physical Stressors

Thermal stressors, entrainment and impingement were the relevant physical stressors evaluated in the EcoRA since they are widely recognized as being of primary concern in nuclear power plants, as recommended by CSA N288.6-12.

Thermal Effects

Cooper (2013) evaluated lake temperatures in the vicinity of the PN U5-8 discharge using 2011-2012 data provided by OPG from thermal dataloggers placed on the substrate. Temperature results at locations in the thermal plume and in reference areas (Thickson

Point and Bonnie Brae Point) were compared to thermal criteria for 15 fish species and HQ values were calculated for relevant time periods for each species at each location. Thermal criteria relevant to spawning and embryo-larval periods, and juvenile and adult stages were presented for weekly and daily averaging periods (MWAT and STDM criteria).

An HQ above 1 is indicative of potential adverse effects from the thermal plume. HQs were presented for the highest temperature location in the plume area, and in the reference area. For fish spawning and embryo-larval development, the highest HQs were marginally above 1 in the plume, but usually very similar in the reference.

OPG (2017) evaluated the effect of lake water temperature from the thermal plume at PN on Round Whitefish embryo survival for the winters of 2009-2010, 2010-2011 and 2011-2012 using a thermal survival model. The model used a revised Hybrid Block 1 Model and the COG Block 3 Model, where Block 1 refers to the early incubation period of Round Whitefish embryos and Block 3 refers to late incubation period. The estimated survival loss at the plume stations compared to the reference stations (Thickson Point and Bonnie Brae) was 0.80% in 2009-2010, 1.39% in 2010-2011, and 2.51% in 2011-2012. These values for survival loss are all below a survival loss of 10%, the recommended threshold for no-effect on Round Whitefish embryo survival. Therefore, the thermal plume from PN is not having an effect on Round Whitefish embryo survival.

An average water temperature of 6°C during the spawning and egg incubation period has been adopted as a threshold effect level. All plume stations in 2009-2010, 2010-2011 and 2011-2012 were below the threshold effect level. Likewise, the mean temperature at each of the 16 individual stations in the PN thermal plume was below the threshold effect level of 6°C in each year (OPG, 2017). Therefore, based on the thermal survival model calculations and the mean water temperatures being below the thermal effect level, the thermal plume from PN is not having an adverse effect on the development of Round Whitefish embryos.

For fish growth (juvenile and adult), the highest HQs were marginally above 1 in the plume for Lake Trout, Rainbow Trout, White Sucker and Threespine Stickleback, but were less than or equal to reference values for all these species. Therefore, it is unlikely that there are any effects arising from the thermal plume in the lake for juvenile or adult stages of any fish species.

Entrainment and Impingement

In October 2008, OPG was ordered by the CNSC to reduce fish impingement at the Pickering station by 80%, and to reduce fish entrainment by 60%, relative to the baseline year (2003/04). In order to reduce impingement, OPG installed a barrier net in October 2009. No reasonable technological solution is available to reduce entrainment by 60% (OPG, 2012h), but these losses are more than offset by operation of the FDS and by OPG support for projects to create Northern Pike spawning and nursery habitat (OPG, 2012h),

and by OPG participation in the Bring Back the Salmon Program (Lake Ontario Atlantic Salmon Restoration Program, 2011).

Overall, biomass lost to impingement was reduced relative to baseline by 75 to 91% on an annual basis over the 2010 to 2014 period (average 81%). Biomass per unit of CCW flow was reduced by 79 to 92% on an annual basis over the same period (average 84%). These reductions in impinged biomass are considered to meet or exceed the 80% reduction target.

In 2015, the biomass lost was reduced only 53% on an annual basis. This was due to a single impingement event on 28 May, 2015, in which large numbers of alewife were impinged. This event occurred during the installation of the FDS, which is installed annually after the ice melts in Lake Ontario. During the first phase of affixing two pieces, the FDS came apart, allowing the fish to be impinged. Except for this one event, impingement was typical of that observed over the 2010 to 2014 period, at 0.67 mg/m³ of flow.

The FDS only reduces the impingement component of fish losses at the Pickering cooling water intake. The entrainment losses will be similar to those reported prior to FDS installation. The impact of entrainment losses, in terms of production foregone, is an order of magnitude less than the impact of impingement losses.

The combined losses prior to the FDS installation, considering adult equivalents and production foregone, were found to be very small relative to commercial and recreational harvests (Golder, 2007g; SENES, 2008). Since the major part of this loss has been reduced by approximately 80%, losses that were of little ecological consequence before the FDS will be smaller and even less consequential now that the FDS is in operation. Since OPG is seeking an authorization under the Fisheries Act, any further mitigation would be determined as a result of the authorization process.

5.2 Recommendations for the Monitoring Program

Based on sampling conducted from 2014 to 2015 (and parts of 2016), OPG has addressed many of the recommendations for supplementary monitoring recommended in the 2014 ERA (EcoMetrix, 2014). If radiation or chemical doses were predicted to exceed benchmarks and the exceedances are reasonably expected to be facility related, it is recommended that OPG confirm exposure conditions, and proceed either to monitor for the effects relevant to benchmark exceedances, or to evaluate options for risk management if the need for risk management is clear. The confirmation of exposure may involve refinement of exposure estimates from existing data, or obtaining new monitoring data where exposures were based on predicted concentrations.

In order to clarify risk in future human and ecological assessments, the following specific recommendations for monitoring are provided:

- Although site soil data from 2015 confirms localized areas of contamination (Site 14 SS3, SS5, SS6, GMS-28, and GMS-31, as shown on Figure 4.5), no specific monitoring or remediation is recommended at this stage, as the contamination will be addressed during decommissioning of the PN site. According to the preliminary decommissioning plan for the PN site all contamination exceeding the established clearance levels for a 'brown field' site will be removed from the site or remediated on site in order to restore the site to a state suitable for other OPG uses (OPG, 2016f).
- To further assess the potential for thermal effects to Round Whitefish embryos in the thermal plume over the period of continued operation of PN, it is recommended that a thermal monitoring study be conducted in the vicinity of the PN U5-8 CCW discharge to confirm the predictions made in the ERA and the associated potential effects on the survival of Round Whitefish embryos. The study should be conducted during one winter season (December to April). The thermal monitoring study and the effects assessment on Round Whitefish survival will then be incorporated into the next ERA update.

In order to reduce uncertainty in future human and ecological assessments, the following specific recommendations for monitoring are provided:

- As identified in the 2014 ERA, the only exposure pathway for receptors at Hydro Marsh is through airborne deposition of tritium from atmospheric emissions from PN. Sampling of water at Hydro Marsh could be performed to confirm that effects from tritium deposition in the marsh are minor. This one time supplementary study is being conducted as part of the EMP in the 2016 sampling year. The results will be available in the 2016 EMP report published in 2017.

5.3 Risk Management Recommendations

No risk management recommendations are made at this time.

6.0 REFERENCES

Agency for Toxic Substances and Disease Registry (ATSDR). 2010. Toxicological Profile for Chlorine. November.

Agency for Toxic Substances and Disease Registry (ATSDR). 2008. Toxicological Profile for Aluminum. September.

Ager, D., X. Lin and D. Rodgers. 2008. Pickering Nuclear Generating Station Thermal Plume Discharge Studies 2006-2007. Report prepared for Ontario Power Generation. Report No. P-REP-00541-0242524. March.

Auer, M.T., L.M. Tomlinson, S.N. Higgins, S.Y. Malkin, E.T. Howell and H.A. Bootsma. 2010. Great Lakes *Cladophora* in the 21st Century: same algae – different ecosystem. J. Great Lakes Res. 36:248-255.

Barbiero, R.P. and M.L. Tuchman. 2001. Results from the U.S. EPA's Biological Open Water Surveillance Program of the Laurentian Great Lakes: I. Introduction and Phytoplankton Results. J. Great Lakes Res. 27(2): 134-154.

Barbiero, R.P., R.E. Little and M.L. Tuchman. 2001. Results from the U.S. EPA's Biological Open Water Surveillance Program of the Laurentian Great Lakes: III. Crustacean Zooplankton. J. Great Lakes Res. 27(2): 167-184.

Beresford, N.A., Barnett, C.L., Howard, B.J., Scott, W.A., Brown, J.E., Coplestone, D. 2008. Derivation of transfer parameters for use within the ERICA Tool and the default concentration ratios for terrestrial biota. Journal of Environmental Radioactivity, 99. 1393-1407.

Beyer, W.N., E. Connor, and S. Gerould. 1994. Estimates of Soil Ingestion by Wildlife. J. Wildl. Manage. 58(2): 375-382.

Bird, G.A., P.A. Thompson, C.R. MacDonald and S.C. Sheppard. 2002. Assessment of the Impact of Radionuclide Releases from Canadian Nuclear Facilities on Non-Human Biota. Third Int. Symposium on the Protection of the Environment from Ionizing Radiation. Darwin, Australia.

Borgmann, U., Couillard, Y., Doyle, P. and Dixon, D.G. 2005. Toxicity of Sixty-Three Metals and Metalloids to *Hyalella Azteca* at Two Levels of Water Hardness. *Journal of Environmental Toxicology and Chemistry*. 24(3), 641-652.

British Columbia Ministry of Environment (BC MOE). 2013. Ambient Water Quality Guidelines for Sulphate. Technical Appendix Update. April.

- British Columbia Ministry of Environment (BC MOE). 2008. Ambient Water Quality Guidelines for Iron.
- British Columbia Ministry of Environment (BC MOE). 1996. Animal Weights and Their Water and Food Requirements.
- Brown, J., Strand, P., Hosseini, A. and Borretzen, P. 2003. Handbook for Assessment of the Exposure of Biota to Ionising Radiation from Radionuclides in the Environment. FASSET Deliverable 5.
- Canadian Council of Ministers of the Environment (CCME). 2008. Canada-Wide Standard for Petroleum Hydrocarbons (PHC) in Soil: Scientific Rationale Supporting Technical Document. PN 1399. January.
- Canadian Council of Ministers of the Environment (CCME). 1999a. Canadian Environmental Quality Guidelines. Canadian Council of Ministers of the Environment.
- Canadian Council of Ministers of the Environment (CCME). 1999b. Canadian Soil Quality Guidelines for the Protection of Environmental and Human Health: Thallium 1999.
- Canadian Council of Ministers of the Environment (CCME). 1997. Canadian Soil Quality Guidelines for the Protection of Environmental and Human Health: Cyanide (Free) 1997.
- Canadian Environmental Protection Act, 1999* (S.C. 1999, c. 33). Persistence and Bioaccumulation Regulations SOR/2000-107.
- Canadian Nuclear Safety Commission (CNSC). 2009. CNSC Letter, L. Levert to D.P. McNeil, OPG. Record of Proceedings – Ontario Power Generation Inc. January 26, 2009, e-Doc 3330500, CD# NK30-CORR-00531-05083.
- Canadian Nuclear Safety Commission (CNSC). 2008a. Pickering NGS A- Return to Service Environmental Assessment: Request for Approval in Principle to Revised the Scope of the Follow-up and Monitoring Program, New Action #2008-4-12. NA44-CORR-00531-05915.
- Canadian Nuclear Safety Commission (CNSC). 2008b. CNSC Letter, J. Bouchard to M. Elliott, Record of Proceeding – Ontario Power Generation Inc. December 2008. NA44-CORR-00531-05978.
- Canadian Nuclear Safety Commission (CNSC). 2004. CNSC Letter, S. Locatelli to K. Nash, Record of Proceedings – Ontario Power Generation. May 28, 2004. CD# 92896-CORR-00531-00233.

- Canadian Nuclear Safety Commission (CNSC). 2001. Record of Proceedings, Including Reasons for Decision. November. http://www.nuclearsafety.gc.ca/eng/the-commission/pdf/PICK_E.pdf
- Canadian Standards Association (CSA). 2012. Environmental risk assessments at Class I nuclear facilities and uranium mines and mills. CSA N288.6-12.
- Canadian Standards Association (CSA). 2011. Effluent monitoring programs at Class I nuclear facilities and uranium mines and mills. CSA N288.5-11.
- Canadian Standards Association (CSA). 2010. Environmental monitoring programs at Class I nuclear facilities and uranium mines and mills. CSA N288.4-10.
- Canadian Standards Association (CSA). 2008. Guidelines for calculating derived release limits for radioactive material in airborne and liquid effluents for normal operation of nuclear facilities. CSA N288.1-08.
- Chapman, G. A., S. Ota, and F. Recht. n.d. Effects of water hardness on the toxicity of metals to *Daphnia magna*. U.S. Environmental Protection Agency, Corvallis, Oregon
Daphnia magna. U.S. Environmental Protection Agency, Corvallis, Oregon.
- CH2M Gore and Storrie, 2000. Tritium in Groundwater Study. Report No. NA44-REP-07010-10001. September.
- CH2M Hill. 2007. Phase II Environmental Site Assessments Site #14 – Site Drainage Ditches. Report No. NK30-REP-10120-00008. April.
- CH2M Hill. 2006. Phase II Environmental Site Assessments Site #4 – East Site Pipe Fabrication Shop Pickering NGS. Report No. NK30-REP-10120-00038. September.
- CH2M Hill. 2005a. Phase II Environmental Site Assessments Site #1 – PN5-8 Transformer Area and Oil Tank Farm Area Pickering NGS. Report No. NK30-REP-10120-10039. September.
- CH2M Hill. 2005b. Phase II Environmental Site Assessments Site #3 – East Site Old Hazardous Goods Storage Building Pickering NGS. Report No. NK30-REP-10120-00037. September.
- CH2M Hill. 2005c. Phase II Environmental Site Assessments Site #12 – Oil and Chemical Storage Building Pickering NGS. Report No. NK30-REP-10120-00036. September.
- Cooper, F. 2013. Thermal effects Risk Assessment for the Darlington and Pickering Nuclear Generating Stations. COG-12-3053. CANDU Owners Group.

- Coutant, C.C. 1977. Cold shock to aquatic organisms: guidance for power plant siting, design and operation. *Nuclear Safety* 18:329-342.
- Cuthbert, F.J., L.R. Wires, and K. Timmerman. 2003. Status Assessment and Conservation Recommendations for the Common Tern (*Sterna hirundo*) in the Great Lakes Region. Prepared for the U.S. Fish and Wildlife Service. September 2003.
- Durham Region Health Department (DRHD). 2016. Population at a Glance. Available at: https://www.durham.ca/departments/health/health_statistics/popAtAGlance.pdf
- Durham Region Health Department (DRHD). 2007. Radiation and Health in Durham Region 2007. April.
- Durham Region Health Department (DRHD). 1996. Radiation and Health in Durham Region. Durham Region Health Department
- Durham Region Planning Department (DRPD). 2015. Durham Region Profile. Demographics and Socio-economic Data. Available at: <http://www.durham.ca/departments/planned/planning/stats-n-facts/durhamprofile/DetailedReport.pdf>
- EcoMetrix. 2015. Pickering EMP Supplementary Study – Hydrazine in Lake Water – 2014. February. Report No. P-REP-03443-0538647.
- EcoMetrix. 2014. Environmental Risk Assessment Report for Pickering Nuclear. OPG Report No. P-REP-07010-10012. January.
- EcoMetrix. 2012. Pickering Nuclear Generating Station Groundwater Monitoring Program. Report No. P-REP-10120-10037-R000. September.
- Efroymsen, R.A., M.E. Will, G.W. Suter II. 1997a. Toxicological Benchmarks for Contaminants of Potential Concern for Effects on Soil and Litter Invertebrates and Heterotrophic Process: 1997 Revision. Office of Environmental Management, Oak Ridge National Laboratory. ES/ER/TM-126/R2.
- Efroymsen, R.A., M.E. Will, G.W. Suter, II and A.C. Wooten. 1997b. Toxicological Benchmarks for Screening Contaminants of Potential Concern for Effects on Terrestrial Plants: 1997 Revision. ES/ER/TM-85/R3. Oak Ridge National Laboratory, Oak Ridge.
- Elphick, J., Davies, M., Gilron, G., Canaria, E., Lo, B. and Bailey, H. 2011. An Aquatic Toxicological Evaluation of Sulfate: The Case for Considering Hardness as a Modifying Factor in Setting Water Quality Guidelines. *Journal of Environmental Toxicology and Chemistry*. 30(1), 247-253.
- Environment Canada (EC). 2013. *Canadian Environmental Protection Act*, 1999 Federal Environmental Quality Guidelines Hydrazine. February.

- Environment Canada (EC). 2009a. Durham Regional Coastal Wetland Monitoring Project: 6-year Technical Report. Module 1 – Introduction and Assessment Methods.
- Environment Canada (EC). 2009b. Durham Regional Coastal Wetland Monitoring Project: 6-year Technical Report. Module 3 – Biological Condition.
- Environment Canada (EC). 1999. Canadian Soil Quality Guidelines for Free Cyanide (Environmental Effects) – Scientific Supporting Document –December.
- Environment Canada (EC). 1997. The Canada Country Study: Climate Impacts and Adaptation. Ontario Region Executive Summary. Available at: <http://www.on.ec.gc.ca/canada-country-study/#current>
- Environment Canada and Health Canada (EC/HC), 2011. Screening Assessment for the Challenge. Hydrazine. CAS Registry Number 302-01-2.
- Environment Canada and Health Canada (EC/HC). 2003. Priority Substances List Assessment Report: Releases of Radionuclides from Nuclear Facilities (Impact on Non-Human Biota).
- Environment Canada, US EPA and NYDEC, 1998, Lakewide Management Plan for Lake Ontario. Environment Canada, USEPA, Ontario, NYDEC. Available at: <http://www.epa.gov/greatlakes/lakeont/ch-3.pdf>
- ERICA Tool. 2011. ERICA Tool version June 2011.
- European Chemicals Agency (ECHA). 2008. Morpholine Calc Key Distribution Modelling. Available at: <https://echa.europa.eu/registration-dossier/-/registered-dossier/13364/5/5/4>
- European Commission. 2006. Review of QSAR Models for Bioconcentration. Report No. EUR 22327.
- Faure, Gunter. 1998. Principles and Applications of Geochemistry. Prentice Hall. New Jersey.
- Fisher, D.J., D.T. Burton, L.T. Yonkos, S.D. Turley and G.P. Ziegler. 1999. The relative acute toxicity of continuous and intermittent exposures of chlorine and bromine to aquatic organisms in the presence and absence of ammonia. Water Res. 33: 760-768.
- Gangon. 2011. Effects of PNGS Thermal Plume on Round Whitefish Embryos. OPG Report No. NK30-REP-07250-0380641.
- Golder Associates Ltd. and EcoMetrix Incorporated (Golder and EcoMetrix). 2017. Pickering Safe Storage Project Predictive Effects Assessment. Report No. P-REP-07701-00002, R0. April.

- Golder Associates Ltd. (Golder). 2014. Emission Summary and Dispersion Modelling Report – Appendix E Emergency Equipment Assessment Version 1.1. Report No. P-REP-00541-00014 R000. May.
- Golder Associates Ltd. (Golder). 2011. Emission Summary and Dispersion Modelling Report. Report No. P-REP-00541-00014-R000. May.
- Golder Associates Ltd. (Golder). 2009. Surface Water Environment Existing Environmental Conditions Technical Support Document New Nuclear – Darlington Environmental Assessment. Report No. NK054-REP-07730-00002. September.
- Golder Associates Ltd. (Golder). 2007a. Surface Water Resources Technical Support Document Refurbishment and Continued Operation of Pickering B Nuclear Generating Station Environmental Assessment. Report No. NK30-REP-07701-00007. April.
- Golder Associates Ltd. (Golder). 2007b. Aquatic Environment Technical Support Document Refurbishment and Continued Operation of Pickering B Nuclear Generating Station Environmental Assessment. Report No. NK30-REP-07701-00008. March.
- Golder Associates Ltd. (Golder). 2007c. Terrestrial Environment Technical Support Document Refurbishment and Continued Operation of Pickering B Nuclear Generating Station Environmental Assessment. Report No. NK30-REP-07701-00009. March.
- Golder Associates Ltd. (Golder). 2007d. Geology, Hydrogeology and Seismicity Technical Support Document Refurbishment and Continued Operation of Pickering B Nuclear Generating Station Environmental Assessment. Report No. NK30-REP-07701-00006. March.
- Golder Associates Ltd. (Golder). 2007e. Element 3.2 – Surface Water 2006 Post-Restart Follow-Up Monitoring Program Pickering A Return to Service. Report No. NA44-REP-07701-0196511. February.
- Golder Associates Ltd. (Golder). 2007f. Element 3.6 – Storm Water Quality Follow-Up Monitoring Program Pickering A Return to Service. Report No. NA44-REP-07701-0196512. March.
- Golder Associates Ltd. (Golder). 2007g. Pickering Nuclear Generating Station B Final Report Analysis of Impingement and Entrainment Impacts on the Lake Ontario Fishery. NK30-REP-07260-00001. Ontario Power Generation.
- Golder Associates Ltd. 2003. Geology and Hydrogeology Technical Support Document to Pickering Water Management Facility Phase II Environmental Assessment Study. Report No. 92896-REP-07701-00007. June.

- Government of Canada. 2016. Canadian Climate Normals 1981-2010. Available at: http://climate.weather.gc.ca/climate_normals/
- Great Lakes Fishery Commission (GLFC). 2016. Lake Ontario Fish Communities and Fisheries: 2015 Annual Report of the Lake Ontario Management Unit. Report ISSN 1201-8449.
- Great Lakes Fishery Commission (GLFC). 2011. Lake Ontario Fish Communities and Fisheries: 2010 Annual Report of the Lake Ontario Management Unit. Report ISSN 1201-8449.
- Great Lakes Fishery Commission (GLFC). 2010. Lake Ontario Fish Communities and Fisheries: 2009 Annual Report of the Lake Ontario Management Unit. Report ISSN 1201-8449.
- Griffiths, J.S. 1980. Potential Effects of Unstable Thermal Discharges on Incubation of Round Whitefish Eggs. Ontario Hydro Research Division Report No. 80-140-K.
- Hart, D. 2008. Derived Release Limits. 2008. COG-06-3090-R2-I. November.
- Hart, D. and K. Peterson. 2013. Results of Site Specific Sampling and Analysis of Sediments near Canadian CANDU Facilities. COG-12-3045. April
- Health Canada (HC). 2012. Guidelines for Canadian Drinking Water Quality - Summary Table. Water, Air and Climate Change Bureau, Healthy Environments and Consumer Safety Branch, Health Canada, Ottawa, Ontario.
- Health Canada (HC). 2010. Federal Contaminated Site Risk Assessment in Canada, Part I: Guidance on Human Health Preliminary Quantitative Risk Assessment (PQRA), Version 2.0. Contaminated Sites Program. September
- Health Canada (HC). 2009. Guidelines for Canadian Drinking Water Quality – Chlorine Guideline Technical Document. June.
- Health Canada (HC). 2004. Federal Contaminated Site Risk Assessment in Canada, Part I: Guidance on Human Health Preliminary Quantitative Risk Assessment (PQRA). Contaminated Sites Program. September.
- Health Canada (HC). 2002. A Summary of the Health Hazard Assessment of Morpholine in Wax Coatings of Apples. Available at: http://www.hc-sc.gc.ca/fn-an/securit/facts-faits/exec_summary-resume_exec-eng.php
- Health Canada (HC). 1992. Guidelines for Canadian Drinking Water Quality: Guideline Technical Document - Sodium

- Higgins, S.N., S.Y. Malkin, E.T. Howell, S.J. Guildford, L. Campbell, V. Hiriart-Baer and R.E. Hecky. 2008. An Ecological Review of *Claodphora Glomerata* (Chlorophyta) in the Laurentian Great Lakes. *J. Phycol.* 44(4): 839-854.
- International Atomic Energy Agency (IAEA). 2010. Handbook of Parameter Values for the Prediction of Radionuclide Transfer in Terrestrial and Freshwater Environments. Technical Reports Series No. 472.
- International Atomic Energy Agency (IAEA). 1992. Effects of Ionizing Radiation on Plants and Animals at Levels Implied by Current Radiation Protection Standards. TRS No. 332. IAEA, Vienna.
- International Commission on Radiological Protection (ICRP). 2008. Environmental Protection: The Concept and Use of Reference Animals and Plants. Publication 108.
- International Joint Commission (IJC). 1997. Inventory of Radionuclides for the Great Lakes. December
- Kjølholt, Jesper, Frank Stuer-Lauridsen, Anders Skibsted Mogensen and Svend Havelund. 2003. *The Elements in the Second Rank – an Environmental Problem Now or in the Future*. Danish Environmental Protection Agency, Environmental Project 770, 2003, Miljøprojekt. March.
- Lake Ontario Atlantic Salmon Restoration Program. 2011. Bring Back the Salmon. Summer 2011 Newsletter.
- Lampman, G.G. and Makarewicz, J.C. 1999. The phytoplankton zooplankton link in the Lake Ontario food web. *J. Great Lakes Res.* 25:239–249.
- MacDonald. D.D. 1999. A Compendium of Environmental Quality Benchmarks. MacDonald Environmental Sciences Limited, Prepared for Environment Canada.
- Madejon, P., Murillo, J.M., Maranon, T., Lepp, N.W. 2007. Factors affecting accumulation of thallium and other trace elements in two wild Brassicaceae spontaneously growing on soils contaminated by tailings dam waste. *Chemosphere*, 67: 20-28.
- Makeeva, A.P., N.G. Yemel'yanova, N.B. Velova and I.N. Ryabou. 1995. Radiobiological analysis of Silver Carp, *Hypophthalmichthys molitrix*, from the cooling pond of the Chernobyl Nuclear Power Plant since the time of the accident. 2. Development of the reproductive system in the first generation of offspring. *J. Ichthyology*, 35: 40-64.
- NatureServe. 2013. NatureServe Explorer: An Online Encyclopedia of Life. Verson 7.1 (2 February 2009). Updated July 2013. Available at: <http://www.natureserve.org/explorer/>

- Nuclear Safety and Control Act. SC 1997, c.9 General Nuclear Safety and Control Regulations. SOR/2000-202. Radiation Protection Regulations. SOR/2000-203.
- Ontario Commercial Fisheries Association (OCFA). 2016. Fisheries Statistics. Lake Ontario. Available at: <http://www.ocfa.ca/fisheries-industry/fisheries-statistics>
- Ontario Ministry of the Environment and Climate Change (MOECC). 2013a. Ontario Drinking Water Surveillance Program. Available at: <http://www.ontario.ca/data/drinking-water-surveillance-program>
- Ontario Ministry of the Environment and Climate Change (MOECC). 2013b. Environmental Noise Guideline, Stationary and Transportation Sources – Approval and Planning. NPC 300.
- Ontario Ministry of the Environment (MOE). 2012. Ontario's Ambient Air Quality Criteria. Standards Development Branch. April.
- Ontario Ministry of the Environment (MOE). 2011. Rationale for the Development of Soil and Ground Water Standards for Use at Contaminated Sites in Ontario. Standards Development Branch. April.
- Ontario Ministry of the Environment (MOE). 2009a. Procedure for Preparing an Emission Summary and Dispersion Modelling Report. Version 3.0. PIBs # 3614e03. March.
- Ontario Ministry of the Environment (MOE). 2009b. Hinterland Who's Who: Red-winged Blackbird. Available at: <http://www.hww.ca/assets/pdfs/factsheets/red-winged-blackbird-en.pdf>
- Ontario Ministry of Environment and Energy (MOEE). 1994. Water Management: Policies Guidelines Provincial Water Quality Objectives of the Ministry of Environment and Energy. Ontario Ministry of Environment and Energy, Queen's Printer for Ontario. July.
- Ontario Ministry of Environment and Energy (MOEE). 1993. Ontario Typical Range of Chemical Parameters in Soil, Vegetation, Moss Bags and Snow. Ontario Ministry of Environment and Energy, Queen's Printer for Ontario. December.
- Ontario Ministry of Environment and Energy (MOEE). 1979. Rationale for Establishment of Ontario's Provincial Water Quality Objectives. Ontario Ministry of Environment and Energy.
- Ontario Ministry of Natural Resources and Forestry (MNR). 2016a. Genetic analysis of round whitefish (*Prosopium cylindraceum*) stock structure in Lake Ontario. Technical Report TR-11.

- Ontario Ministry of Natural Resources and Forestry (MNR). 2016b. Lake Ontario Fish Communities and Fisheries: 2015 Annual Report of the Lake Ontario Management Unit. Ontario Ministry of Natural Resources and Forestry, Picton, Ontario, Canada.
- Ontario Ministry of Natural Resources and Forestry (MNR). 2015. Lake Ontario Fish Communities and Fisheries: 2014 Annual Report of the Lake Ontario Management Unit. Ontario Ministry of Natural Resources and Forestry, Picton, Ontario, Canada
- Ontario Power Generation (OPG). n.d. Health and Safety Management System. OPG-PROG-0010.
- Ontario Power Generation (OPG). n.d. Radiation Protection. N-PROG-RA-0013 R007.
- Ontario Power Generation (OPG). 2017. Potential Effect Of The Thermal Plume From The Pickering Nuclear Generating Station On The Survival Of Round Whitefish Embryos. P-REP-07250-00005-R000. March.
- Ontario Power Generation (OPG). 2016a. Pickering Nuclear Site Species List 2015. P-LIST-07811-00001-R005. April.
- Ontario Power Generation (OPG). 2016b. Pickering Nuclear 2015 Impingement Monitoring Report. P-REP-07263-00009-R000. April.
- Ontario Power Generation (OPG). 2016c. 2015 Results of Environmental Monitoring Programs. Report No. N-REP-03443-10015-R00. April.
- Ontario Power Generation (OPG). 2016d. 2015 Pickering Nuclear Groundwater Monitoring Program Results. Report No. P-REP-10120-00041. March.
- Ontario Power Generation (OPG). 2016e. 2015 Pickering Nuclear Environmental Compliance Approval (Industrial Sewage - #4881-5MHQ9F and #4988-6R6J73) Annual Performance Report. Report No. P-REP-00541-00022. May.
- Ontario Power Generation (OPG). 2016f. Preliminary Decommissioning Plan - Pickering Generating Stations A & B. Report No. P-PLAN-00960-00001.
- Ontario Power Generation (OPG). 2015a. 2014 Results of Environmental Monitoring Programs. Report No. N-REP-03443-10014-R00. April.
- Ontario Power Generation (OPG). 2015b. 2014 Pickering Nuclear Groundwater Monitoring Program Results. Report No. P-REP-10120-00040. March.
- Ontario Power Generation (OPG). 2015c. Pickering Nuclear 2014 Impingement Monitoring Report. Report No. P-REP-07263-00008. June.

- Ontario Power Generation (OPG). 2015d. 2014 MISA Annual Report - Pickering Nuclear (MISA Company Code 0001840206). Report No. P-REP-00541.08-00005. February.
- Ontario Power Generation (OPG). 2015e. Emission Summary and Dispersion Modelling Report. Report No. P-REP-00541-00014-R001. August.
- Ontario Power Generation (OPG). 2015f. 2015 Pickering Nuclear Environmental Compliance Approval (#4766-A3YMB9). Report No. P- CORR-00541-00820. December.
- Ontario Power Generation (OPG). 2015g. 2014 Pickering Nuclear Environmental Compliance Approval (Industrial Sewage 4881-5MHQ9F). Report No. P-REP-00541-00020-R000. May.
- Ontario Power Generation (OPG). 2014a. Reassessment of the impact of thermal plumes on round whitefish egg survival and hatch using the new COG model. Memorandum from D. Brown to S. Rapin. N-REP-07250-0518222. 17 October.
- Ontario Power Generation (OPG). 2014b. Pickering Nuclear 2013 Impingement Monitoring Report. Report No. P-REP-07263-00007. June.
- Ontario Power Generation (OPG). 2014c. Pickering Nuclear Environmental Compliance Approval (Industrial Sewage 4881-5MHQ9F) Annual Performance Report – 2013. Report No. P-REP-00541-00019-R000. May.
- Ontario Power Generation (OPG). 2013a. Pickering Waste Management Facility - Safety Report. Report No. 92896·SR·01320·10002·R005. November
- Ontario Power Generation (OPG). 2013b. Review of the Pickering Nuclear Site Specific Survey. Report No. P-REP-03481-00001. February.
- Ontario Power Generation (OPG). 2013c. 2011-2013 East Landfill Perpetual Care Program Report. Report No. P-REP-10120-10038. May.
- Ontario Power Generation (OPG). 2013d. PNGS Thermal Plume Monitoring During Winter of 2011-2012. Report No. P-REP-07250-00004. October.
- Ontario Power Generation (OPG). 2013e. Pickering Nuclear Generating Station 2012 Impingement Monitoring Report. Report No. P-REP-07263-00006. July.
- Ontario Power Generation (OPG). 2013f. Pickering Nuclear Environmental Compliance Approval (Industrial Sewage 4881-5MHQ9F) Annual Performance Report – 2012. Report No. P-REP-00541-00018-R000. May.
- Ontario Power Generation (OPG). 2012a. Pickering A Safety Report. Report No. NA44-SR-01320-00001-R015. July.

- Ontario Power Generation (OPG). 2012b. Pickering Nuclear 2011 Municipal Industrial Strategy for Abatement (MISA) Annual Data Summary Report. Report No. P-REP-67090-0413215. May.
- Ontario Power Generation (OPG). 2012c. Pickering Nuclear Site Species List – 2011. P-LIST-07811-00001. July.
- Ontario Power Generation (OPG). 2012d. 2011 Results of Radiological Environmental Monitoring Programs. Report No. N-REP-03481-10010. April.
- Ontario Power Generation (OPG). 2012e. Pickering Nuclear Consolidated Certificate of Approval (Industrial Sewage 4881-5MHQ9F) Annual Performance Report – 2011. Report No. P-REP-00541-00017-R000. May.
- Ontario Power Generation (OPG). 2012f. PNGS Thermal Plume Monitoring During Winter of 2010-2011. Report No. P-REP-07250-00003. May.
- Ontario Power Generation (OPG). 2012g. Mitigation of Fish Entrainment at PNGS. P-REP-07262-00001-R000. April.
- Ontario Power Generation (OPG). 2012h. Pickering Nuclear Generating Station 2011 Impingement Monitoring Report. Report No. P-REP-07263-00003-R000. July.
- Ontario Power Generation (OPG). 2011a. Derived Release Limits and Environmental Action Levels for Pickering Nuclear Generating Station A. Report No. NA44-REP-03482-00001 Rev 002. January.
- Ontario Power Generation (OPG). 2011b. Derived Release Limits and Environmental Action Levels for Pickering Nuclear Generating Station B. Report No. NK30-REP-03482-00001 Rev 002. January.
- Ontario Power Generation (OPG). 2011c. Acoustic Assessment of Pickering Nuclear Generating Station, Supporting Document for a Renewal of a Basic Comprehensive Certificate of Approval (C of A) – Air & Noise). Report No. P-REP-00541-00015 R00.
- Ontario Power Generation (OPG). 2011d. Pickering Nuclear Site Biodiversity and Natural Areas Management Plan: 2012-2014. Report No. P-REP-07811-00011. September.
- Ontario Power Generation (OPG). 2011e. Pickering Nuclear 2010 Municipal Industrial Strategy for Abatement (MISA) Annual Data Summary Report. Report No. P-REP-67090-0373981. May.
- Ontario Power Generation (OPG). 2011f. 2009-2010 East Landfill Perpetual Care Program Bi-Annual Report. Report No. P-REP-10120-00034. June.

- Ontario Power Generation (OPG). 2011g. 2010 Results of Radiological Environmental Monitoring Programs. Report No. N-REP-034181-10009-R000. April.
- Ontario Power Generation (OPG). 2011h. 2008-2010 Spill Trend Report. Report No. N-REP-07292-10004. May.
- Ontario Power Generation (OPG). 2011i. Pickering Nuclear 2010 Impingement Monitoring Report. Report No. P-REP-07263-00001-R000. July.
- Ontario Power Generation (OPG). 2011j. Amendment to Certificate of Approval Industrial Sewage Works Number 4881-5MHQ9F. P-CORR-00541-00712-R000. February 10, 2011.
- Ontario Power Generation (OPG). 2010a. 2010 PN and DN DRL Supporting Document – Meteorological Data, N-REP-03482-10021.
- Ontario Power Generation (OPG). 2010b. Methodology for Data Analysis and Public Dose Determination for the Radiological Environmental Monitoring Program. Report No. N-INS-03481.21-10000. May.
- Ontario Power Generation (OPG). 2010c. Pickering Nuclear 2009 MISA Year End Summary Report. Report No. P-REP-67090-0280021. May.
- Ontario Power Generation (OPG). 2010d. 2009 Results of Radiological Environmental Monitoring Programs. Report No. N-REP-03481-10008-R000. April.
- Ontario Power Generation (OPG). 2010e. Impact of PNGS Thermal Discharge During the Winter of 2010 on Potential Round Whitefish Spawning. Report No. P-REP-07250-00001-R000. August.
- Ontario Power Generation (OPG). 2010f. OPG Letter, N. Mihalic to P. Jones, Pickering Waste Management Facility Phase II – Environmental Assessment Follow-up Report 2010 – Submission of Enclosures. July 30, 2010. E-Doc 3589043, CD# 92896-CORR-00531-00532.
- Ontario Power Generation (OPG). 2009a. Pickering B Safety Report – Part 1. Report No. NK30-SR-01320-00001-R003. September.
- Ontario Power Generation (OPG). 2009b. 2008 Results of Radiological Environmental Monitoring Programs. Report No. N-REP-03481-10007. April.
- Ontario Power Generation (OPG). 2008. OPG Letter, W.M. Elliot to T.E. Schaubel, Pickering NGS-A – Guaranteed Defuelled State Environmental Impact Statement Submission. June 30, 2008. CD# NA44-CORR-0053 1-05809.

- Ontario Power Generation (OPG). 2007a. Annual Follow-up And Monitoring Report 2006 Pickering Nuclear Generating Station A Return To Service Environmental Assessment. Report No. NA44-REP-07701-0196518. April 30.
- Ontario Power Generation (OPG). 2007b. OPG Letter, D.P. McNeil to T.E. Schaubel, CNSC, Pickering B Environmental Assessment (EA) for Proposed Refurbishment and Continued Operation – Submission of Final EA Study Report. December 17, 2007. CD# NK30-CORR-00531-04644.
- Ontario Power Generation (OPG). 2007c. Dosimetry and Radiological Environmental Quality Assurance Program Manual. Document No. N-MAN-03416.3-0020, November.
- Ontario Power Generation (OPG). 2006a. Review of Pickering Nuclear Site Specific Survey. Report No. P-REP-03481-00001. November.
- Ontario Power Generation (OPG). 2006b. Assessment of Gross Alpha Monitoring Requirement for RLWMS and ALW at Pickering and Darlington Nuclear. Report No. N-REP-03480-10007. October.
- Ontario Power Generation (OPG). 2005a. OPG Letter, K.E. Nast to K.Klassen, Pickering Waste Management Facility Phase II – Environmental Assessment Follow-up Plan, Mary 31, 2005, 92896-CORR-00531-00277.
- Ontario Power Generation (OPG). 2005b. Gross Alpha Monitoring in Radioactive Effluent Monitoring Program. Document No. N-CORR-00531-03171. February.
- Ontario Power Generation (OPG). 2003. OPG Letter, K.E. Nash to M. Ben Belfadhel, “Pickering Waste Management Facility Phase II Project - Submission of Final Environmental Assessment Study Report,” December 19, 2003, CD# 92896-CORR-00531-00205.
- Ontario Power Generation (OPG). 2002a. Pickering Wind Turbine – Results of Environmental Monitoring Program to Determine Bird Mortality. P-CORR-00531-01271.
- Ontario Power Generation (OPG). 2002b. Metal Concentrations in Sediments and Other Endpoints In The Vicinity Of Pickering NGS "A" -2000-2001, P-REP-07000.015-00001, March 2002.
- Ontario Power Generation (OPG). 2001. Follow-Up and Monitoring Program, Pickering NGS-A Return to Service Environmental Assessment. Report NA44-REP-07701.1-00001. August
- Ontario Power Generation (OPG). 2000a. Pickering A Return to Service Environmental Assessment Report Volume 1 Main Report. Report NA44-REP-07730-{372537}. April.

- Ontario Power Generation (OPG). 2000b. OPG Letter, G. Preston to Dr. M. P. Measures (CNSC). Development of Generic Criterion for Tritium in Groundwater not used as Drinking Water. Sept 28, 2000. N-CORR-00531-00892.
- ORTECH Power. 2008. Review and Performance Assessment of the Darlington and Pickering Nuclear Meteorological Tower Data for Ontario Power Generation Inc., N-REP-03481-0309535, 2008-12-15.
- Patrick, P., Mason, E., Parks, J., Powell, J. Garisto, N., and Janes. A. 2014. Effects of fixed and fluctuation temperatures on mortality and hatch of Round Whitefish and Lake Whitefish eggs. COG Report COG-13-3025. October.
- Pinchin Environmental (Pinchin). 2010. Final Human Health and Ecological Risk Assessment Update Pickering Nuclear Generating Station Standby Generator Stations SG-A and SG-B. Report No. NK30-REP-54600-00113. October.
- Poupin P., N. Truffaut, B. Combourieu, P. Besse, M. Sancelme, H. Veschambre, and A.M. Delort. 1998. Degradation of Morpholine by an Environmental *Mycobacterium* Strain Involves a Cytochrome P-450. Appl. Environm. Microbiol. 64(1): 159-165.
- Sample, B.E., J.J. Beauchamp, R.A. Efrogmson, G.W. Suter II, and T.L. Ashwood. 1998. Development and Validation of Bioaccumulation Models for Earthworms. ES/ER/TM-220. February.
- SENES Consultants Limited (SENES). 2009. 34300 – Pickering Impingement Age-1 Equivalent and Production Foregone Preliminary Estimates. Memorandum to Ontario Power Generation. Report No. NK30-REF-07730-0265050. May.
- SENES Consultants Limited (SENES). 2007a. Ecological Risk Assessment Technical Support Document Refurbishment and Continued Operation of Pickering B Nuclear Generating Station Environmental Assessment. Report No. NK30-REP-07701-00005. June.
- SENES Consultants Limited (SENES). 2007b. Human Health Technical Support Document Refurbishment and Continued Operation of Pickering B Nuclear Generating Station Environmental Assessment. Report No. NK30-REP-07701-00015. December.
- SENES Consultants Limited (SENES). 2007c. Radiation and Radioactivity Technical Support Document Refurbishment and Continued Operation of Pickering B Nuclear Generating Station Environmental Assessment. Report No. NK30-REP-07701-00004. April.
- SENES Consultants Limited (SENES). 2007d. Atmospheric Environment Technical Support Document Refurbishment and Continued Operation of Pickering B Nuclear Generating Station Environmental Assessment. Report No. NK30-REP-07701-00003. February.

- SENES Consultants Limited (SENES). 2007e. Refurbishment and Continued Operation of Pickering B Nuclear Generating Station Environmental Assessment. Report No. NK30-REP-07701-00002. December.
- SENES Consultants Limited (SENES). 2002. Tier 3 Ecological Risk Assessment of Pickering Nuclear Phase (iv). Report No. P-REP-07010-10009. December.
- SENES Consultants Limited (SENES). 2001. Tier 2 Ecological Risk Assessment of Pickering Nuclear Phase (iii) Pickering Nuclear Screening Ecological Risk Assessment. Report No. P-REP-07010-10009. November.
- SENES Consultants Limited (SENES). 2000. Ecological Risk Assessment of Pickering Nuclear Phase (ii) Pickering Nuclear Screening Ecological Risk Assessment. Report No. P-REP-07010-10008. September.
- SENES Consultants Limited (SENES). 1999. Ecological Risk Assessment of Pickering Nuclear Phase (i): Methodology and Work Plan Supporting Document. October. Report No. P-REP-07010-10007 Rev: 000.
- Sheppard, S.C., J.M. Long and B. Sanipelli. 2010. Measured elemental transfer factors for boreal hunter/gatherer scenarios: fish, game and berries. *J. Environ. Radioact.* 101(11): 902-909.
- Sheppard, S.C., J.M. Long and B. Sanipelli. 2009. Field measurements of the transfer factors for iodine and other trace elements. NWMO TR-2009-35. December.
- Shibata, M.A., Kurata, Y., Ogiso, T., Tamano, S., Fukushima, S., and Ito, N. 1987. Combined chronic toxicity and carcinogenicity studies of morpholine oleic acid salt in B6C3F1 mice. *Food Chem. Toxicol.* 25: 569-574.
- Skoryna, S.C. 1981. Effects of Oral Supplementation with Stable Strontium. *CMA Journal* 125: 703-712.
- Slonim AR, Gisclard JB. 1976. Hydrazine degradation in aquatic systems. *Bull. Environ. Contam. Toxic.* 01(16): 301-309.
- Storey, M.L. and J.L. Greger. 1987. Iron, Zinc and Copper Interaction: Chronic Versus Acute Responses of Rats. *J. Nutr.* 117(8):1434-1442.
- Suter, G.W. II. 1996. Risk Characterization for Ecological Risk Assessment of Contaminated Sites. Oak Ridge National Laboratory. Oak Ridge.
- Suter, G.W., Barnthouse, L.W., Bartell, S.M., Mill, T., Mackay, D., Paterson, S.. 1993. Ecological Risk Assessment. Lewis Publishers, Chelsea, MI.

- Suter, G.W., Tsao, C.L. 1996. Toxicological Benchmarks for Screening Potential Contaminants of Concern for Effects on Aquatic Biota. ES/ER/TM-96/R2. June.
- Suter, G.W.II., B.E. Sample, D.S. Jones. T.L. Ashwood, and J.M. Loar. 1995. Approach and Strategy for Performing Ecological Risk Assessments for the U.S. Department of Energy's Oak Ridge Reservation: 1995 Revision. U.S. Department of Energy.
- Texas Commission on Environmental Quality (TCEQ). 2015. Effects Screening Levels. Retrieved from, <http://www.tceq.texas.gov/toxicology/esl/ESLMain.html/#elevels>
- Thompson et al. 1972. Concentration Factors of Chemical Elements in Edible Aquatic Organisms. UCRL-50564.
- Toronto and Region Conservation Authority (TRCA). 2015. Ontario Power Generation Terrestrial Long-Term Monitoring Project (2015 Monitoring Season). December. Report No. P-REP-07811-0584553.
- Toronto and Region Conservation Authority (TRCA). 2014. Ontario Power Generation Terrestrial Long-Term Monitoring Project (Year 5). March. Report No. P-REP-07811-00012.
- Toronto and Region Conservation Authority (TRCA). 2013. Ontario Power Generation Landfill. Terrestrial Biological Inventory and Assessment. December. Report No. P-REP-07811-0508418.
- Toronto and Region Conservation Authority (TRCA). 2009a. OPG Study Area Terrestrial Biological Inventory and Assessment. January. Report No. P-REP-07811-0615910.
- Toronto and Region Conservation Authority (TRCA). 2009b. Frenchman's Bay Harbour Entrance Environmental Impact Study. March. Available at: <http://www.trca.on.ca/dotAsset/50330.pdf>
- Toronto and Region Conservation Authority (TRCA). 2007. Terrestrial Natural Heritage System Strategy. Available at: <https://trca.ca/conservation/greenspace-management/terrestrial-natural-heritage/>
- UNSCEAR. 2008. Sources and Effects of Ionizing Radiation. UNSCEAR 2008 Report to the General Assembly with Scientific Annexes. Annex E. Effects of Ionizing Radiation on Non-human Biota. United Nations Scientific Committee on Effects of Ionizing Radiation. United Nations, New York
- UNSCEAR. 1996. Sources and Effects of Ionizing Radiation. United Nations Scientific Committee on the Effects of Atomic Radiation, 1996 Report to the General Assembly, with annexes. United Nations Sales Publication E.96.IX.3. United Nations, New York, NY.

- Urban, D.J. and N.J. Cook. 1986. Hazard Evaluation, Standard Evaluation Procedure, Ecological Risk Assessment. EPA-540/9-85-001. U.S. Environmental Protection Agency. Washington, D.C.
- U.S. Army Center for Health Promotion and Preventive Medicine (USACHPPM). 2004. Development of Terrestrial Exposure and Bioaccumulation Information for the Army Risk Assessment Modeling System (ARAMS). Available at:
<http://el.erdc.usace.army.mil/arams/pdfs/usachppm.pdf>
- U.S. Environmental Protection Agency (US EPA). 2009. Integrated Risk Information System – Hydrazine/Hydrazine Sulfate. Available from <http://www.epa.gov/iris/subst/0352.htm>
- U.S. Environmental Protection Agency (US EPA). 2005. Human Health Risk Assessment Protocol for Hazardous Waste Combustion Facilities. EPA/530-R-05-006.
- U.S. Environmental Protection Agency (US EPA). 2003. Region 5 RCRA Ecological Screening Levels. August 22, 2003. Available from
<http://www.epa.gov/Region5/waste/cars/pdfs/ecological-screening-levels-200308.pdf>
- U.S. Environmental Protection Agency (US EPA). 2001. 2001 Update of Ambient Water Quality Criteria for Cadmium. April 2001.
- U.S. Environmental Protection Agency (US EPA). 1995. Final National Pollutant Discharge Elimination System Storm Water Multi-Sector General Permit for Industrial Activities; Notice, September 29, 1995.
- U.S. Environmental Protection Agency (U.S. EPA). 1993. Wildlife Exposure Factors Handbook. EPA/600/R-93/187. U.S. EPA, Washington, D.C.
- U.S. Environmental Protection Agency (US EPA). 1991. Hydrazine/Hydrazine sulfate (CASRN 302-01-2). Integrated Risk Information System. Available at:
<http://www.epa.gov/iris/subst/0352.htm#carc>
- U.S. Environmental Protection Agency (US EPA). 1983. Water Quality of Typical Urban Runoff- US EPA NURP.
- U.S. Department of Health and Human Services (HHA). 2010. Toxicological Profile for Chlorine. November 2010.
- Vahl, H.A. and A.T. Van T'Klooster. 1987. Dietary Iron and Broiler Performance. Br. Poultry Sci. 28(4):567-576.
- Wang, Y.-Y., B.M. Biber and C. Yu. 1993. A Compilation of Radionuclide Transfer Factors for the Plant, Meat, Milk, and Aquatic Food Pathways and the Suggested Default Values for the RESRAD Code, ANL/EAIS/TM-103, prepared by Argonne National Laboratory,

Ill., for the U.S. Department of Energy, Office of Environmental Guidance and Office of Environmental Restoration, Washington, D.C.

Winter, J.G., E.T. Howell and L.K. Nakamoto. 2012. Trends in nutrients, phytoplankton, and chloride in nearshore waters of Lake Ontario: Synchrony and relationships with physical conditions. *J. Great Lakes Res.* 38: 124 – 132.

Wismer, D.A. and A.E. Christie. 1987. Temperature Relationships of Great Lakes Fishes. A Data Compilation. Great Lakes Fishery Commission Special Publication No. 87-3.

Wood, J., J.A. Hoyle, and C. Wilson. 2016. Genetic analysis of round whitefish (*Prosopium cylindraceum*) stock culture in Lake Ontario. Ministry of Natural Resources and Forestry Technical Report TR-11.

World Health Organization (WHO). 2011. Guidelines for Drinking Water Quality Fourth Edition.

World Health Organization (WHO). 2010. Strontium and Strontium Compounds. Concise International Chemical Assessment Document 77.

World Health Organization (WHO). 1996. Environmental Health Criteria for Morpholine. Available at:
<http://www.inchem.org/documents/ehc/ehc/ehc179.htm#SubSectionNumber:4.2.3>

Zach, R. and S.C. Sheppard. 1992. *The Food-Chain and Dose Submodel, CALDOS, for the Assessment of Canada's Nuclear Fuel Waste Management Concept*. Atomic Energy of Canada Limited, Report No. AECL-10165, COG-91-195.

Appendix A Screening Tables Used for the HHRA and EcoRA

Table A.1: Non-Radiological Screening of Air COPCs for Human Health

Contaminant	CAS No.	Aggregate Emission Rate (g/s)					Max 1/2 Hour POI Concentration (µg/m³) ^a	1/2 hour Limit (µg/m³)	Limiting Effect	Regulation Schedule No.	% of Limit	Annual Concentration (µg/m³)	Derived Annual Criteria (µg/m³)	Reference for Derived Annual Criteria	Carried Forward as COPC?
		2011-1 ^b	2011-2 ^c	2015-1 ^b	2015-2 ^c	Max (g/s)									
2-(2-aminoethoxy) ethanol	929-06-6	5.50E-02	5.50E-02	5.50E-02	5.50E-02	5.50E-02	5.49E-01	5.56E-01		Previously approved limit in CoFA	98.68	0.036	38	TCEQ, 2015	No
Acetic Acid	64-19-7	3.33E-01	3.33E-01	3.33E-01	3.33E-01	3.33E-01	3.32E+00	25000	Odour	Schedule 2	0.01	N/A	N/A	N/A	No
Acetone	67-64-1	3.36E-02	3.36E-02	3.36E-02	3.36E-02	3.36E-02	3.35E-01	3.56E+04	Health	Schedule 2	0.00	N/A	N/A	N/A	No
Ammonia	7664-41-7	2.12E+01	2.12E+01	2.12E+01	2.12E+01	2.12E+01	2.11E+02	300	Health	Schedule 2	70.49	N/A	N/A	N/A	No
Ammonium Hydroxide	1336-21-6	2.14E-03	2.14E-03	2.14E-03	2.14E-03	2.14E-03	2.13E-02	3.00E+02		JSL	0.01	N/A	N/A	N/A	No
Amyl Alcohol	71-41-0	1.07E-04	1.07E-04	1.07E-04	1.07E-04	1.07E-04	1.07E-03	1.11E-03		Previously approved limit in CoFA	96.16	6.92E-05	73	TCEQ, 2015	No
Carbon monoxide	630-09-0	1.48E+01	2.47E+01	1.48E+01	2.47E+01	2.47E+01	1.45E+02	6000	Health	Schedule 2	2.42	N/A	N/A	N/A	No
Deuterium	7782-39-0	3.17E-07	3.17E-07	3.17E-07	3.17E-07	3.17E-07	3.16E-06	3.00E-01		De minimus	0.00	N/A	N/A	N/A	No
Ethanolamine	141-43-5	1.10E+00	1.10E+00	1.10E+00	1.10E+00	1.10E+00	1.10E+01	1.11E+01		Previously approved limit in CoFA	98.86	0.711	7.00	TCEQ, 2015	No
Ethylene	74-85-1	9.53E-02	9.53E-02	9.53E-02	9.53E-02	9.53E-02	9.51E-01	9.60E-01		Previously approved limit in CoFA	99.03	0.062	34	TCEQ, 2015	No
Formic Acid	64-18-6	2.40E-01	2.40E-01	2.40E-01	2.40E-01	2.40E-01	2.39E+00	1.50E+03	Health	Schedule 2	0.16	N/A	N/A	N/A	No
Glycolic Acid	79-14-1	8.90E-03	8.90E-03	8.90E-03	8.90E-03	8.90E-03	8.88E-02	1.71E-01		Previously approved limit in CoFA	51.92	0.006	2	TCEQ, 2015	No
Fuel Oil No. 2	68476-30-2	2.80E-01	2.80E-01	2.80E-01	2.80E-01	2.80E-01	2.79E+00	1.20E+03		JSL	0.23	N/A	N/A	N/A	No
Hexane	110-54-3	7.01E-03	7.01E-03	7.01E-03	7.01E-03	7.01E-03	6.99E-02	2.25E+04	Health	Schedule 2	0.00	N/A	N/A	N/A	No
Hydrazine	302-01-2	Replaced in 2015	1.87E-03	1.87E-03	1.87E-03	1.87E-03	1.80E-04	Annual Concentration from AERMOD			0.00	6.9E-04 ^d	2.00E-04	US EPA IRIS	Yes
Hydrogen Chloride	7647-01-0	2.14E-02	2.14E-02	2.14E-02	2.14E-02	2.14E-02	2.13E-01	60	Health	Schedule 2	0.36	N/A	N/A	N/A	No
Hydroquinone	123-31-9	8.90E-03	8.90E-03	8.90E-03	8.90E-03	8.90E-03	8.88E-02	8.99E-02		Previously approved limit in CoFA	98.76	0.006	2	TCEQ, 2015	No
Isopropyl Alcohol	67-63-0	2.14E-03	2.14E-03	2.14E-03	2.14E-03	2.14E-03	2.13E-02	2.20E+04	Health	Schedule 2	0.00	N/A	N/A	N/A	No
Methane	74-82-8	1.61E-03	1.61E-03	1.61E-03	1.61E-03	1.61E-03	1.61E-02	3.00E-01		De minimus	5.35	N/A	N/A	N/A	No
Methanol	67-56-1	6.73E-02	6.73E-02	6.73E-02	6.73E-02	6.73E-02	6.71E-01	1.20E+04	Health	Schedule 2	0.01	N/A	N/A	N/A	No
Methylamine	74-89-5	1.40E-01	1.40E-01	1.40E-01	1.40E-01	1.40E-01	1.40E+00	25	Odour	Schedule 2	5.59	N/A	N/A	N/A	No
Methylene Chloride	75-09-2	2.25E-01	2.25E-01	2.25E-01	2.25E-01	2.25E-01	2.24E+00	6.60E+02	Health	Schedule 2	0.34	N/A	N/A	N/A	No
Mineral Spirits	N/A	2.14E-03	2.14E-03	2.14E-03	2.14E-03	2.14E-03	2.13E-02	3000	Odour	Schedule 2	0.00	N/A	N/A	N/A	No
Morpholine	110-91-8	3.00E+01	3.00E+01	3.00E+01	3.00E+01	3.00E+01	2.99E+02	48		JSL	623.47	19.40	40	TCEQ, 2015	No
Nitric Acid	7697-37-2	1.07E-02	1.07E-02	1.07E-02	1.07E-02	1.07E-02	1.07E-01	100	Corrosion	Schedule 2	0.11	N/A	N/A	N/A	No
Nitrogen oxides	10102-44-0	5.29E+01	8.53E+01	5.29E+01	8.53E+01	8.53E+01	4.78E+02	500	Health	Schedule 2	95.60	N/A	N/A	N/A	No
Particulate matter	N/A	9.54E-01	4.04E+01	9.54E-01	4.04E+01	4.04E+01	2.42E+01	100	Visibility	Schedule 2	24.20	N/A	N/A	N/A	No
Phosphoric Acid (as P2O5)	7664-38-2	2.14E-03	2.14E-03	2.14E-03	2.14E-03	2.14E-03	2.13E-02	100	Particulate	Schedule 2 (2013)	0.02	N/A	N/A	N/A	No
Polyethylene glycol ether	84133-50-6	8.65E-01	8.65E-01	Removed	Removed	Removed	N/A	N/A	N/A	N/A	N/A	N/A	N/A	N/A	No
Sodium hypochlorite	7681-52-9	1.19E+00	1.19E+00	1.19E+00	1.19E+00	1.19E+00	1.19E+01	12.1		Previously approved limit in CoFA	98.11	0.770	5	TCEQ, 2015	No
Sulphur dioxide	7446-09-5	3.34E+01	4.21E+01	3.34E+01	4.21E+01	4.21E+01	3.33E+02	830	Health	Schedule 2	40.12	N/A	N/A	N/A	No
Sulphur hexafluoride	2551-62-4	3.46E-03	3.46E-03	3.46E-03	3.46E-03	3.46E-03	3.45E-02	1.80E+06	Health	POJ	0.00	N/A	N/A	N/A	No
Sulphuric Acid	7664-93-9	8.55E-03	8.55E-03	8.55E-03	8.55E-03	8.55E-03	8.53E-02	15	Health	Schedule 2 (2013)	0.57	N/A	N/A	N/A	No
Toluene	108-88-3	6.41E-05	6.41E-05	6.41E-05	6.41E-05	6.41E-05	6.39E-04	2.00E+03	Odour	Schedule 2	0.00	N/A	N/A	N/A	No
Total hydrocarbons	N/A	2.73E-01	5.18E+00	2.73E-01	5.18E+00	5.18E+00	7.07E+00	9.03		Previously approved limit in CoFA	78.29	0.458	100	TCEQ, 2015 (Fuel Oil No. 2)	No
Trimethylbenzene, 1,2,4-	95-63-6	2.95E+00	2.95E+00	2.95E+00	2.95E+00	2.95E+00	2.94E+01	660	Odour	Schedule 2 (2013)	4.46	N/A	N/A	N/A	No
Xylenes	1330-20-7	2.14E-04	2.14E-04	2.14E-04	2.14E-04	2.14E-04	2.13E-03	2200	Health	Schedule 2	0.00	N/A	N/A	N/A	No

Notes:

ND = No Data, N/A = Not Applicable

^a Concentration estimated based dispersion factor at property line of 9.9755 µg/m³ (Golder, 2011; OPG, 2015e).

^b Maximum Emission Scenario 1: One Standby Gas Turbine Generating Set -A Side (ER1), two Standby Gas Turbine Generating Sets -B Side (ER2), Base Case sources

^c Maximum Emission Scenario 2: Two Standby Gas Turbine Generating Sets B Side (ER2), One S7 MW Combustion Turbine with Associated Generator (ERS7), Base Case sources

^d Maximum annual concentration at property boundary (OPG, 2015e)

Table A.2: Human Health Screening of Non-Radiological Final Station Effluent from Condenser Cooling Water

Parameters	Unit	PWQO	Canadian DWQG (HC, 2012)	ECA Limit	Selected Screening Level	Max Conc.	PN U1-4					PN U5-8					Carried forward as COPC?
							Annual Range (2011)	Annual Range (2012)	Annual Range (2013)	Annual Range (2014)	Annual Range (2015)	Annual Range (2011)	Annual Range (2012)	Annual Range (2013)	Annual Range (2014)	Annual Range (2015)	
Unionized Ammonia	mg/L	0.02	None required	0.02	0.02	0.02	<0.001-0.011	<0.01-0.01	<0.01-0.015	<0.01-0.019	<0.01-0.01	<0.01-0.02	<0.01-0.01	<0.01-0.018	<0.01-0.01	<0.01-0.01	No
Hydrazine	mg/L	-	0.00001 ^a	0.1	0.00001 ^d	0.033	<0.002-0.006	<0.002-0.009	<0.002-0.015	<0.002-0.017	<0.002-0.006	<0.002-0.005	<0.002-0.011	<0.002-0.015	<0.002-0.033	<0.002-0.008	Yes
Morpholine	mg/L	0.004 ^a	-	0.02	0.004 ^a	0.007	0.001-0.004	<0.001-0.002	<0.001-0.005	<0.001-0.007	<0.001-0.002	0.001-0.168 ^c	0.001-0.004	<0.001-0.006	<0.001-0.003	<0.001-0.082 ^a	Yes
pH	pH units	6.5-8.5	6.5-8.5	6.0-9.5	6.5-8.5	8.9	7.9-8.3	8.0-8.6	8.0-8.7	7.9-8.9	7.9-8.4	7.9-8.4	8.0-8.5	8.0-8.6	8.1-8.7	8.1-8.4	No
TRC	mg/L	0.002	0.04-2.0 ^b	0.01	0.04-2.0 ^b	0.01	<0.001-0.016	<0.001-0.004	<0.002-0.007	<0.002-0.002	<0.002-0.004	<0.001-0.004	<0.001-0.01	<0.002-0.002	0-0.004	<0.002-0.003	No

Notes:

^a Interim PWQO is conservatively derived based on limited information; no scientific criteria document.

^b No limit set, but at these concentrations, taste and odour related to chlorine or its by-products are generally within the range of acceptability for most consumers, according to Health Canada.

^c This elevated number was retracted since it was determined through a third-party review that the elevated concentrations were suspect and due to mislabeling or sample contamination during analysis

^d This elevated number was not supported by morpholine usage and discharges and was likely related to contamination during sampling or analysis

^e US EPA cited in EC/HC (2011) - Drinking water concentration that corresponds to a cancer risk level of 1x10⁻⁶

Table A.3: Screening of Lake Water COPCs for Human Health

General Chem	Analyte	Unit	Detection Limit	PWQO	Interim PWQO	Canadian Drinking Water Quality Guidelines (HC, 2012)	ODWS/MOE GW1 Component Value (MOE, 2011)	CCME	2015 Mean Background (LWC-1)	Surface Water Screening Level ¹⁾	Ref	Max Observed 2015 Lake Water	Carried Forward as COPC?	% above/below background	Notes
Alkalinity (Total as CaCO3)	mg/L		1						93	93	(2)	110	No	15%	Exceeds background by <20% (Suter et al. 1995; Suter, 1996)
Ammonia Nitrogen	mg/L		0.05						<0.05	--		<0.05	--		
Un-ionized Ammonia, calculate	mg/L		0.0032	0.02				0.019	<0.0016	0.02	(4)	<0.0020	--		
Biochemical Oxygen Demand, 5 Da	mg/L		2						2.26	--		3	--		
Chemical Oxygen Demand	mg/L		4						5.4	--		8.6	--		
Conductivity	ms/cm		0.001						0.314	--		0.5	--		
Conductivity, field measure	ms/cm								0.259	--		0.375	--		
Hardness, Calcium Carbonate	mg/L		1			None requirec			127.5	--		160	--		
Temperature, field measure	°C								12.33	--		23.11	--		
Total Suspended Solids	mg/L		1						<1-<10	<1-<10	(2)	6	No	47%	
pH	pH units			6.5-8.5				6.5-9.0	7.9025	6.5 - 8.5	(4)	8.18	No		
pH, field measure	pH units								8.14	6.5 - 8.5	(4)	8.34	No		
Total Residual Chlorine, field measured	mg/L		0.0012	0.002		0.04- 2.0 ⁷⁾		0.0005	<0.0012	0.002	(4)	<0.0012	No		
Metals/Metalloids															
Aluminum	mg/L		0.005			0.1		0.1	0.007	0.1	(7)	0.033	No		
Aluminum, filtered	mg/L		0.005		0.075				0.009	0.075	(4)	<0.0050	No		
Antimony	mg/L		0.0005		0.02	0.006	0.006		<0.0005	0.006	(7)	<0.0005	No		
Arsenic	mg/L		0.001	0.1		0.01	0.025	0.005	<0.0010	0.01	(7)	<0.0011	No		
Barium	mg/L		0.002			1			0.02225	1	(7)	0.024	No		
Beryllium	mg/L		0.0005	1.1			0.004		<0.0005	0.004	(3)	<0.0005	No		
Bismuth	mg/L		0.001						<0.001	<0.001	(2)	<0.001	No		
Boron	mg/L		0.01		0.2 ¹⁰⁾	5	5	1.5	0.0255	5	(7)	0.028	No		
Cadmium	mg/L		0.0001	0.0002	0.0005	0.005	0.005	0.00004 - 0.00037	0.0000095	0.005	(7)	0.000019	No		
Calcium	mg/L		0.2						34	34	(2)	37	No	8%	Exceeds background by <20% (Suter et al. 1995; Suter, 1996)
Chromium	mg/L		0.005	0.0089			0.05	0.0089	<0.0050	0.05	(3)	<0.0050	No		
Cobalt	mg/L		0.0005	0.0009			0.003		<0.0005	0.003	(3)	<0.0005	No		
Copper	mg/L		0.001	0.005	0.005	1	1	0.002	<0.0010	1	(7)	0.0088	No		
Lead	mg/L		0.1	0.025	0.005	0.01	0.01	0.001-0.007	<0.0005	0.01	(7)	<0.0005	No	0%	
Lithium	mg/L		0.0005						<0.005	<0.005	(2)	<0.005	No		
Magnesium	mg/L		0.005						8.775	8.775	(2)	9	No	3%	Exceeds background by <20% (Suter et al. 1995; Suter, 1996)
Manganese	mg/L		0.05	1 ¹⁰⁾		0.05	0.05		<0.0020	0.05	(7)	0.017	No		
Mercury	mg/L		0.0001	0.0002		0.001	0.001	0.000026	0.00001	0.001	(7)	0.00001	No		
Molybdenum	mg/L		0.002		0.04		0.07	0.073	0.0013	0.07	(3)	0.0014	No		
Nickel	mg/L		0.0005	0.025			0.1	0.025-0.15	0.001025	0.1	(3)	0.0015	No		
Potassium	mg/L		0.001						1.625	1.625	(2)	1.7	No	4%	Exceeds background by <20% (Suter et al. 1995; Suter, 1996)
Selenium	mg/L		0.2	0.1		0.01	0.01	0.001	0.00013875	0.01	(7)	0.00021	No		
Silicon	mg/L		0.05						0.26	--		0.86	--		
Silver	mg/L		0.002	0.0001		none requirec	0.1	0.0001	<0.0001	0.1	(3)	<0.0001	No		
Sodium	mg/L		0.0001			≤200	200		14.5	≤200	(7)	23	No		
Strontium	mg/L		0.1						0.18	0.18	(2)	0.19	No	5%	Exceeds background by <20% (Suter et al. 1995; Suter, 1996)
Tellurium	mg/L		0.001						<0.0010	<0.0010	(2)	<0.0010	No	0%	
Thallium	mg/L		0.001		0.0003 ¹⁰⁾		0.002	0.0008	<0.000050	0.002	(3)	<0.000050	No		
Tin	mg/L		0.00005						<0.0010	<0.0010	(2)	<0.0010	No	0%	
Titanium	mg/L		0.001						<0.005	<0.005	(2)	<0.005	No	0%	
Tungsten	mg/L		0.005		0.03				<0.0010	0.03	(6)	<0.0010	No		
Uranium	mg/L		0.001		0.005 ¹⁰⁾	0.02	0.02	0.015	0.0003675	0.02	(7)	0.00042	No		
Vanadium	mg/L		0.0001				0.006	0.0062	<0.0005	0.0062	(3)	0.00059	No		
Zinc	mg/L		0.0005	0.03	0.02	≤5	5	0.03	<0.0050	≤5	(7)	0.0062	No		
Zirconium	mg/L		0.005		0.004				<0.0010	0.004	(6)	<0.0010	No		
Iron	mg/L		0.001	0.3		0.3		0.3	<0.1	0.3	(7)	<0.1	No		
PetriHydroCarb															
Petroleum Hydrocarbons - F1 (C6-C10)-BTE	mg/L		0.025				0.82	0.167	<0.025	0.82	(3)	<0.025	No		
Petroleum Hydrocarbons - F1 (C6-C10)	mg/L		0.025				0.82	0.167	<0.025	0.82	(3)	<0.025	No		
Petroleum Hydrocarbons - F2 (C10-C16)	mg/L		0.1				0.3	0.042	<0.1	0.3	(3)	<0.1	No		
Petroleum Hydrocarbons - F3 (C16-C34)	mg/L		0.2				1		<0.2	1	(3)	<0.2	No		
Petroleum Hydrocarbons - F4 (C34-C50)	mg/L		0.2				1.1		<0.2	1.1	(3)	<0.2	No		
Other															
Micopholime	mg/L		0.004		0.004				<0.004	0.004	(6)	0.006	Yes		
Hydrazine	mg/L		0.00005			0.00001 ¹⁰⁾				0.00001	(10)	0.00029 ¹¹⁾	Yes		
Radionuclides															
Tritium	Bq/L		4.4	7000		7000	7000		<4.4	7000	(7,8)	69.1	No		
Carbon-14	Bq/L		0.1				200		<0.1	200	(8)	<0.1	No		
Cobal-60	Bq/L		0.1				2		<0.1	2	(8)	<0.1	No		
Cesium-134	Bq/L		0.1				7		<0.1	7	(8)	<0.3	No		Assessed quantitatively for public interest purposes
Cesium-137	Bq/L		0.1				10		<0.1	10	(8)	<0.1	No		

Notes:
 1. Bold and shaded indicates exceedance of selected surface water quality benchmark. Concentrations of parameters that exceeded background by <20% were not identified as exceedances in the 1
 2. Mean background concentration from LWC-1
 3. Ontario Ministry of the Environment (MOE), 2011. Rationale for the Development of Soil and Ground Water Standards for Use at Contaminated Sites in Ontario. Standards Development Branch.
 4. PWQO Ontario MOE
 5. Interim PWQO was set based on readily available information and was not peer reviewed; the drinking water guideline is used in preference
 6. Interim PWQO
 7. Canadian Drinking Water Quality Guidelines (HC, 2012
 8. Ontario Drinking Water Standards (ODWS, 2002
 9. BC MOE (2001) for hardness of 100 mg/L
 10. US EPA cited in EC/HC (2011) - Drinking water concentration that corresponds to a cancer risk level of 1x⁻⁶
 11. Maximum value from 2014 Supplementary EMP Study (EcoMetric, 201

Table A.4: Screening of Stormwater COPCs for Human and Ecological Health - PN U1-4

Station ID	Catchment 2				Catchment 1				Max Con. At Discharge	Final Conc. In CCW	PWQO	Interim PWQO	CCME Protection of Aquatic Life	Toxicity Benchmark	2015 Mean Background ^(a)	Selected Benchmark	Ref ^(b)	Carried Forward in Risk Assessment?	
	Sample Date	MH137		MH149		20-Aug-15	28-Oct-15	19-Nov-15											11-Jun-16
		20-Aug-15	28-Oct-15	19-Nov-15	11-Jun-16														
General																			
Chloride	mg/L	25	25	27	24	650	110	790	150	790	1.5			640		640	(7)	No	
Conductivity	mS/cm	0.31	0.301	0.323	0.29	2.32	0.521	2.99	0.714	2.99					0.3135			--	
Hardness, Calcium Carbonate	mg/L	120	120	130	120	260	93	430	98	430	1				127.5			--	
pH	pH units	7.97	8.03	8.12	8.01	7.72	7.81	8.11	7.66	8.12		6.5-8.5		6.5-9.0	7.9025	6.5 - 8.5	(4)	No	
Phosphorous	mg/L	0.026	0.059	0.025	0.023	0.069	0.044	0.029	0.11	0.11	0.0002	0.02				0.02	(4)	No	
Total Suspended Solids	mg/L	<10	46	<10	<10	57	17	<10	70	70	0.1				<1-<10	<1-<10	(2)	No	
Toxicity																			
% Mortality of Daphnia Magna in 100% Effluent Treatment	%	0	0	0	0	0	0	0	0	0						--		--	
% Mortality of Rainbow Trout in 100% Effluent Treatment	%	0	0	0	0	0	0	0	0	0						--		--	
Metals																			
Aluminum	ug/L	67	300	110	19	680	350	57	1400	1400	3			100		7.075	100	(7)	No
Antimony	ug/L	<0.50	<0.50	<0.50	<0.50	1	<0.50	0.59	0.56	1	0.002		20		<0.5	20	(6)	No	
Arsenic	ug/L	<1.0	<1.0	<1.0	<1.0	<1.0	<1.0	<1.0	<1.0	<1.0	<0.002	100		5		5	(6)	No	
Barium	ug/L	26	28	26	22	64	19	67	31	67	0.1				22.25	22.25	(2)	No	
Beryllium	ug/L	<0.50	<0.50	<0.50	<0.50	<0.50	<0.50	<0.50	<0.50	<0.5	<0.001	1100			<0.5	1100	(4)	No	
Bismuth	ug/L	<1.0	<1.0	<1.0	<1.0	<1.0	<1.0	<1.0	<1.0	<1.0	0.002				<1	1	(2)	No	
Boron	ug/L	26	19	24	15	32	11	19	<10	32	0.06		200 ^(c)	1500		25.5	1500	(7)	No
Cadmium	ug/L	<0.10	<0.10	<0.10	<0.10	<0.10	<0.10	<0.10	<0.10	<0.10	<0.0002	0.2	0.5	0.04 - 0.37	0.0095	0.04 - 0.37	(7)	No	
Calcium	ug/L	35000	38000	38000	32000	96000	29000	140000	48000	140000	274				34000	34000	(2)	No	
Chromium	ug/L	<5.0	<5.0	<5.0	<5.0	<5.0	<5.0	<5.0	<5.0	<5.0	<0.01	8.9		8.9	<5	8.9	(4.7)	No	
Cobalt	ug/L	<0.50	<0.50	<0.50	<0.50	0.65	<0.50	<0.50	1	1	0.002	0.9			<0.5	0.9	(4)	No	
Copper	ug/L	3.7	5.7	3.7	1.9	7.3	6.5	3.7	8.6	8.6	0.02	5	5	2	<1	2	(7)	No	
Iron	ug/L	110	570	200	<100	1200	450	130	1800	1800	4	300		300	<100	300	(4.7)	No	
Lead	ug/L	<0.50	1.1	<0.50	<0.50	2.7	1.5	<0.50	5.2	5.2	0.01	25	5	1 - 7	<0.5	1 - 7	(7)	No	
Lithium	ug/L	<5.0	<5.0	<5.0	<5.0	<5.0	<5.0	<5.0	<5.0	<5	<0.01				<5	5	(2)	No	
Magnesium	ug/L	8900	8400	8700	8100	13000	3500	5200	20000	20000	39				8775	8775	(2)	No	
Manganese	ug/L	13	37	9.3	2.8	110	59	16	120	120	0.2	1000 ^(d)			<2	1000	(9)	No	
Mercury (filtered)	ug/L	<0.01	<0.01	<0.01	<0.01	<0.01	<0.01	<0.01	<0.01	<0.01	<0.00002	0.2		0.026	0.01	0.026	(7)	No	
Molybdenum	ug/L	1.2	0.96	1.2	1.1	1.3	<0.50	1.2	0.84	1.3	0.003		40	73	1.3	40	(6)	No	
Nickel	ug/L	<1.0	1.3	<1.0	<1.0	2.5	<1.0	2.6	2.6	2.6	0.005	25		25 - 150	1.025	25	(4)	No	
Potassium	ug/L	1700	1600	1700	1600	2200	1100	2400	1900	2400	5				1625	1625	(2)	No	
Selenium	ug/L	<2.0	<2.0	<2.0	<2.0	<2.0	<2.0	<2.0	<2.0	<2	<0.004	100		1	0.13875	1	(7)	No	
Silicon	ug/L	240	810	530	370	2900	1300	2800	3400	3400	7				260	--		--	
Silver	ug/L	<0.10	<0.10	<0.10	<0.10	<0.10	<0.10	<0.10	<0.10	<0.10	<0.0002	0.1		0.1	<0.1	0.1	(4.7)	No	
Sodium	ug/L	15000	14000	16000	14000	380000	63000	430000	99000	430000	842			68000	14500	68000	(12)	No	
Strontium	ug/L	180	170	190	170	680	190	890	300	890	2				180	180	(2)	No	
Tellurium	ug/L	<1.0	<1.0	<1.0	<1.0	<1.0	<1.0	<1.0	<1.0	<1.0	<0.002				<1	1	(2)	No	
Thallium	ug/L	<0.050	<0.050	<0.050	<0.050	<0.050	<0.050	<0.050	0.053	0.053	0.0001		0.3 ^(c)	0.8	<0.05	0.8	(7)	No	
Tin	ug/L	<1.0	<1.0	<1.0	<1.0	<1.0	<1.0	<1.0	<1.0	<1.0	<0.002				<1	1	(2)	No	
Titanium	ug/L	<5.0	16	7.1	<5.0	30	11	<5.0	49	49	0.1				<5	5	(2)	No	
Tungsten	ug/L	<1.0	<1.0	<1.0	<1.0	<1.0	<1.0	<1.0	<1.0	<1.0	<0.002		30		<1	30	(6)	No	
Uranium	ug/L	0.89	0.46	0.62	0.45	0.3	0.33	0.58	0.37	0.89	0.002		5 ^(c)	15	0.3675	15	(7)	No	
Vanadium	ug/L	0.83	1.1	<0.50	<0.50	2.9	1.2	<0.50	3.6	3.6	0.007	6			<0.5	6	(4)	No	
Zinc	ug/L	<5.0	20	12	<5.0	83	43	39	84	84	0.2	30	20	30	<5	20	(6)	No	
Zirconium	ug/L	<1.0	<1.0	<1.0	<1.0	<1.0	<1.0	<1.0	1.1	1.1	0.002		4		<1	4	(6)	No	
Petroleum Hydrocarbons (and BTEX)																			
Benzene	ug/L	<0.20	<0.20	<0.20	<0.20	<0.20	<0.20	<0.20	<0.20	<0.20	<0.0004		100	370		100	(6)	No	
Toluene	ug/L	0.22	<0.20	<0.20	<0.20	<0.20	<0.20	<0.20	<0.20	0.22	0.0004		0.8	2		0.8	(6)	No	
Ethylbenzene	ug/L	<0.20	<0.20	<0.20	<0.20	<0.20	<0.20	<0.20	<0.20	<0.20	<0.0004		8	90		8	(6)	No	
o-Xylene	ug/L	<0.20	<0.20	<0.20	<0.20	<0.20	<0.20	<0.20	<0.20	<0.20	<0.0004		40			40	(6)	No	
m,p-Xylenes	ug/L	<0.40	<0.40	<0.40	<0.40	<0.40	<0.40	<0.40	<0.40	<0.40	<0.0008		2			2	(6)	No	
Xylenes, Total	ug/L	<0.40	<0.40	<0.40	<0.40	<0.40	<0.40	<0.40	<0.40	<0.40	<0.0008				--	--		--	
Petroleum Hydrocarbons - F1 (C6-C10)-BTEX	ug/L	<25	<25	<25	<25	<25	<25	<25	<25	<25	<0.05			167	<25	167	(5)	No	
Petroleum Hydrocarbons - F1 (C6-C10)	ug/L	<25	<25	<25	<25	<25	<25	<25	<25	<25	<0.05			167	<25	167	(5)	No	
Petroleum Hydrocarbons - F2 (C10-C16)	ug/L	<100	<100	<100	<100	<100	<100	<100	<100	<100	<0.2			42	<100	42	(5)	No	
Petroleum Hydrocarbons - F3 (C16-C34)	ug/L	<200	<200	<200	<200	<200	<200	<200	<200	<200	<0.4				<200	--		--	
Petroleum Hydrocarbons - F4 (C34-C50)	ug/L	<200	<200	<200	<200	<200	<200	<200	<200	<200	<0.4				<200	--		--	
Reached Baseline at C50	ug/L	YES	YES	YES	YES	YES	YES	YES	YES	YES					<200	--		--	
Radiological																			
Carbon-14	Bq/L	<20	<20	<20	<20	<20	<20	<20	<20	<20	<0.04				<0.1	200	(8)	No	
Cesium-134	Bq/L	<1	<1	<1	<1	<1	<1	<1	<1	<1	<0.002				<0.1	7	(8)	No	
Cesium-137	Bq/L	<1	<1	<1	<1	<1	<1	<1	<1	<1	<0.002				<0.1	10	(8)	No	
Cobalt-60	Bq/L	-	<1	<1	<1	-	<1	<1	<1	<1	<0.002				<0.1	2	(8)	No	
Tritium (HTO)	Bq/L	21	588	145	163	327	141	882	235	882	2	7000			<4.4	7000	(4.8)	No	

^a 2015 mean background concentration measured in Lake Water (LWC-1)

^b References for Selected Benchmarks correspond to notes section in Lake Water Screening Table A.9.

^c Interim PWQO was set based on readily available information and was not peer reviewed; the CCME guideline is used in preference.

^d BC MOE (2001) for hardness of 100 mg/L (Ambient Water Quality Guidelines for Manganese, Overview Report, British Columbia Ministry of the Environment)

Table A.8: Screening of Non-Radiological Final Station Effluent from Condenser Cooling Water for Ecological Assessment

Parameters	Unit	PWQO	CCME Protection of Aquatic Life	Toxicity Benchmark	ECA Limit	Selected Screening Level	Max Conc.	PA					PB					Carried forward as COPC?
								Annual Range (2011)	Annual Range (2012)	Annual Range (2013)	Annual Range (2014)	Annual Range (2015)	Annual Range (2011)	Annual Range (2012)	Annual Range (2013)	Annual Range (2014)	Annual Range (2015)	
Unionized Ammonia	mg/L	0.02	0.019	0.02	0.02	0.02	0.02	<0.001-0.011	<0.01-0.01	<0.01-0.015	<0.01-0.019	<0.01-0.01	<0.01-0.02	<0.01-0.01	<0.01-0.018	<0.01-0.01	<0.01-0.01	No
Hydrazine	mg/L	-	-	0.0026 ^b	0.1	0.0026 ^b	0.033	<0.002-0.006	<0.002-0.009	<0.002-0.015	<0.002-0.017	<0.002-0.006	<0.002-0.005	<0.002-0.011	<0.002-0.015	<0.002-0.033	<0.002-0.008	Yes
Morpholine	mg/L	0.004 ^a	-	0.004 ^a	0.02	0.004 ^a	0.007	0.001-0.004	<0.001-0.002	<0.001-0.005	<0.001-0.007	<0.001-0.002	0.001-0.168 ^c	0.001-0.004	<0.001-0.006	<0.001-0.003	<0.001-0.082 ^d	Yes
pH	pH units	6.5-8.5	6.5-9.0	6.5-8.5	6.0-9.5	6.5-8.5	8.9	7.9-8.3	8.0-8.6	8.0-8.7	7.9-8.9	7.9-8.4	7.9-8.4	8.0-8.5	8.0-8.6	8.1-8.7	8.1-8.4	No
TRC	mg/L	0.002	-	0.002	0.01	0.002	0.01	<0.001-0.016	<0.001-0.004	<0.002-0.007	<0.002-0.002	<0.002-0.004	<0.001-0.004	<0.001-0.01	<0.002-0.002	0-0.004	<0.002-0.003	Yes

Notes:

^a Interim PWQO is conservatively derived based on limited information; no scientific criteria document.

^b Federal Water Quality Guideline for Freshwater Life (EC, 2013)

^c This elevated number was retracted since it was determined through a third-party review that the elevated concentrations were suspect and due to mislabeling or sample contamination during analysis

^d This elevated number was not supported by morpholine usage and discharges and was likely related to contamination during sampling or analysis

Table A.9: Screening of Lake Water COPCs for Ecological Assessment¹

General Chem	Analyte	Unit	PWQO	Interim PWQO	CCME	Toxicity Benchmark	2015 Mean Background (LWC-1)	Surface Water Screening Level ²	Ref	Max Observed 2015 Lake Water	Carried Forward as COPC?	% above/below background	Notes
Alkalinity (Total as CaCO3)	mg/L	1					93	93	(2)	110	No	15%	Exceeds background by <20% (Suter et al. 1995; Suter, 1996)
Ammonia Nitrogen	mg/L	0.05					<0.05	--		<0.05	--		
Unionized Ammonia, calculator	mg/L	0.0032	0.02		0.019		<0.0016	0.019	(7)	<0.0020			
Biochemical Oxygen Demand, 5 Da	mg/L	2					2.25	--		3	--		
Chemical Oxygen Demand	mg/L	4					5.4	--		8.6	--		
Conductivity	ms/cm	0.001					0.314	--		0.5	--		
Conductivity, field measure	ms/cm						0.259	--		0.375	--		
Hardness, Calcium Carbonate	mg/L	1					127.5	--		160	--		
Temperature, field measure	C						12.33	12.33	(2)	23.11	Yes	47%	
Total Suspended Solids	mg/L	1					<1-<10	<1-<10	(2)	6	No		
pH	pH units		6.5-8.5		6.5-9.0		7.9025	6.5 - 8.5	(4)	8.18	No		
pH, field measure	pH units						8.14	6.5 - 8.5	(4)	8.34	No		
Total Residual Chlorine, field measured	mg/L	0.0012	0.002		0.0005		<0.0012	0.002	(4)	<0.0012	No		
Metals/Metalloids													
Aluminum	mg/L	0.005			0.1		0.007	0.1	(7)	0.033	No		
Aluminum, filterec	mg/L	0.005		0.075			0.009	0.075	(4)	<0.0050	No		
Antimony	mg/L	0.0005		0.02			<0.0005	0.02	(6)	<0.0005	No		
Arsenic	mg/L	0.001	0.1		0.005		<0.0010	0.005	(6)	<0.0011	No		
Barium	mg/L	0.002					0.02225	0.02225	(2)	0.024	No	7%	Exceeds background by <20% (Suter et al. 1995; Suter, 1996)
Beryllium	mg/L	0.0005	1.1				<0.0005	1.1	(4)	<0.0005	No		
Bismuth	mg/L	0.001					<0.001	<0.001	(2)	<0.001	No		
Boron	mg/L	0.01		0.2 ⁽³⁾	1.5		0.0255	1.5	(7)	0.028	No		
Cadmium	mg/L	0.0001	0.0002	0.0005	0.00004 - 0.00037		0.000095	0.00004 - 0.00037	(7)	0.000019	No		
Calcium	mg/L	0.2					34	34	(2)	37	No	8%	Exceeds background by <20% (Suter et al. 1995; Suter, 1996)
Chromium	mg/L	0.005	0.0089		0.0089		<0.0050	0.0089	(4,7)	<0.0050	No		
Cobalt	mg/L	0.0005	0.0009				<0.0005	0.0009	(4)	<0.0005	No		
Copper	mg/L	0.001	0.005	0.005	0.002		<0.0010	0.002	(7)	0.0088	Yes		
Lead	mg/L	0.1	0.025	0.005	0.001-0.007		<0.0005	0.001-0.007	(7)	<0.0005	No		
Lithium	mg/L	0.0005					<0.0005	<0.0005	(2)	<0.0005	No		
Magnesium	mg/L	0.005					8.775	8.775	(2)	9	No	3%	Exceeds background by <20% (Suter et al. 1995; Suter, 1996)
Manganese	mg/L	0.05	1 ⁽⁹⁾				<0.0020	1	(9)	0.017	No		
Mercury	mg/L	0.0001	0.0002		0.000026		0.00001	0.000026	(7)	0.00001	No		
Molybdenum	mg/L	0.002		0.04			0.0013	0.04	(6)	0.0014	No		
Nickel	mg/L	0.0005	0.025		0.025-0.15		0.001025	0.025	(4)	0.0015	No		
Potassium	mg/L	0.001				5.3 ⁽¹²⁾	1.625	1.625	(2)	1.7	No	4%	Exceeds background by <20% (Suter et al. 1995; Suter, 1996)
Selenium	mg/L	0.2	0.1		0.001		0.00013875	0.001	(7)	0.00021	No		
Silicon	mg/L	0.05					0.26	--		0.56	--		
Silver	mg/L	0.002	0.0001		0.0001		<0.0001	0.0001	(4,7)	<0.0001	No		
Sodium	mg/L	0.0001				68	14.5	68	(12)	23	No	37%	Toxicity benchmark is modified LCV (Suter and Tsao, 1996)
Strontium	mg/L	0.1				1.5 ⁽¹²⁾	0.18	0.18	(2)	0.19	No	5%	Exceeds background by <20% (Suter et al. 1995; Suter, 1996)
Tellurium	mg/L	0.001					<0.0010	<0.0010	(2)	<0.0010	No		
Thallium	mg/L	0.001		0.0003 ⁽³⁾	0.0008		<0.000050	0.0008	(7)	<0.000050	No		
Tin	mg/L	0.0005					<0.0010	<0.0010	(2)	<0.0010	No		
Titanium	mg/L	0.001					<0.0005	<0.0005	(2)	<0.0005	No		
Tungsten	mg/L	0.005		0.03			<0.0010	0.03	(6)	<0.0010	No		
Uranium	mg/L	0.001		0.005 ⁽¹¹⁾	0.015		0.0003875	0.015	(7)	0.00042	No		
Vanadium	mg/L	0.0001		0.006			<0.0005	0.006	(6)	0.00059	No		
Zinc	mg/L	0.0005	0.03		0.03		<0.0050	0.02	(6)	0.0062	No		
Zirconium	mg/L	0.005		0.004			<0.0010	0.004	(6)	<0.0010	No		
Iron	mg/L	0.001	0.3		0.3		<0.1	0.3	(4,7)	<0.1	No		
PetrHydroCarb													
Petroleum Hydrocarbons - F1 (C6-C10)-BTE	mg/L	0.025			0.167		<0.025	0.167	(5)	<0.025	No		
Petroleum Hydrocarbons - F1 (C6-C10)	mg/L	0.025			0.167		<0.025	0.167	(5)	<0.025	No		
Petroleum Hydrocarbons - F2 (C10-C16)	mg/L	0.1			0.042		<0.1	0.042	(5)	<0.1	No		
Petroleum Hydrocarbons - F3 (C16-C34)	mg/L	0.2					<0.2	--		<0.2	No		
Petroleum Hydrocarbons - F4 (C34-C50)	mg/L	0.2					<0.2	--		<0.2	No		
Other													
Morpholine	mg/L	0.004		0.004			<0.004	0.004	(6)	0.006	Yes		
Hydrazine	mg/L	0.0005	0.0026 ⁽¹⁰⁾					0.0026	(10)	0.00025 ⁽¹¹⁾	No		
Radionuclides													
Tritium	Bq/L	4.4	7000				<4.4	7000	(4,8)	69.1	No		Assessed quantitatively for public interest purposes
Carbon-14	Bq/L	0.1					<0.1	200	(8)	<0.1	No		
Cobalt-60	Bq/L	0.1					<0.1	2	(8)	<0.1	No		
Cesium-134	Bq/L	0.1					<0.1	7	(8)	<0.3	No		
Cesium-137	Bq/L	0.1					<0.1	10	(8)	<0.1	No		

Notes:
 1. Bold and shaded indicates exceedance of selected surface water quality benchmark. Concentrations of parameters that exceeded background by <20% were not identified as exceedances in the table.
 2. Mean background concentration from LWC-1
 3. Interim PWQO was set based on readily available information and was not peer reviewed; the CCME guideline is used in preference.
 4. PWQO Ontario MOE.
 5. CCME (2008) aquatic protection value calculated for assumed composition of F1 and F2; other PHC fractions considered insufficiently soluble to be of concern as chemical toxicants in water.
 6. Interim PWQO.
 7. CCME Surface Water Quality Guideline for Protection of Aquatic Life.
 8. Ontario Drinking Water Standards (ODWS, 2002).
 9. BC MOE (2001) for hardness of 100 mg/L.
 10. Federal Water Quality Guideline for Freshwater Life (EC, 2011).
 11. Maximum value from 2014 Supplementary EMP Study (EcoMetrix, 2014).
 12. LCV from Suter and Tsao (1996) modified to NOEC.

Table A.10: Screening of Frenchman's Bay Water COPCs for Ecological Assessment

Analyte	Sample Depth/m	Unit	Detection Limit	PWQO	Interim PWQO	CCME	Toxicity Benchmark	2015 Mean Background (LWC-1)	Surface Water Screening Level ⁽¹⁾	Ref	Max Observed 2015 Frenchman's Bay Water	Carried Forward as COPC?	% above/below background	Notes
General Chem														
Alkalinity (Total as CaCO3)		mg/L	1					93	93	(2)	150	No	38%	Exceeds background by >20% (Suter et al. 1995; Suter, 1996)
Ammonia Nitrogen		mg/L	0.05					<0.05	--		<0.05	--		
Un-ionized Ammonia, calculated		mg/L	0.0032	0.02		0.019		<0.0018	0.019	(7)	<0.0069	--		
Biochemical Oxygen Demand, 5 Da		mg/L	2					2.25	--		5	--		
Chemical Oxygen Demand		mg/L	4					5.4	--		15	--		
Conductivity		ms/cm	0.001					0.314	--		0.86	--		
Conductivity, field measure		ms/cm						0.259	--		0.774	--		
Hardness, Calcium Carbonate		mg/L	1					127.5	--		210	--		
Temperature, field measure		C						12.33	12.33	(2)	23.94	Yes	48%	
Total Suspended Solids		mg/L	1					<1-<10	<1-<10	(2)	20	No		
Total Organic Carbon		mg/L	0.2					--	--		4.9	--		
pH		pH units		6.5-8.5		6.5-9.0		7.9025	6.5 - 8.5	(4)	8.26	No		
pH, field measure		pH units						8.14	6.5 - 8.5	(4)	8.56	No		
Total Residual Chlorine, field measured		mg/L	0.0012	0.002		0.0005		<0.0012	0.002	(4)	<0.0012	No		
Metals/Metalloids														
Aluminum		mg/L	0.005			0.1		0.007	0.1	(7)	0.27	Yes		
Aluminum, filtered		mg/L	0.005		0.075			0.009	0.075	(4)	0.006	No		
Antimony		mg/L	0.005		0.02			<0.005	0.02	(6)	<0.0005	No		
Arsenic		mg/L	0.001	0.1		0.005		<0.0010	0.005	(6)	0.0011	No		
Barium		mg/L	0.002			1.5 ⁽¹⁴⁾		0.02225	1.5	(14)	0.046	No		
Beryllium		mg/L	0.0005	1.1				<0.0005	1.1	(4)	<0.0005	No		
Bismuth		mg/L	0.001					<0.001	<0.001	(2)	<0.001	No		
Boron		mg/L	0.01		0.2 ⁽³⁾	1.5		0.0255	1.5	(7)	0.042	No		
Cadmium		mg/L	0.0001	0.0002	0.0005	0.0004 - 0.00037		0.000095	0.0004 - 0.00037	(7)	0.00001	No		
Calcium		mg/L	0.2			1000 (livestock)		34	1000 (livestock)	(7)	64	No		
Chromium		mg/L	0.005	0.0089		0.0089		<0.0050	0.0089	(4,7)	<0.0050	No		
Cobalt		mg/L	0.0005	0.0009				<0.0005	0.0009	(4)	<0.0005	No		
Copper		mg/L	0.001	0.005	0.005	0.002		<0.0010	0.002	(7)	0.0021	Yes		
Lead		mg/L	0.1	0.025	0.005	0.001-0.007		<0.005	0.001-0.007	(7)	0.00092	No		
Lithium		mg/L	0.0005					<0.005	<0.005	(2)	<0.005	No		
Magnesium		mg/L	0.005			600 (livestock) ⁽¹⁴⁾		8.775	600 (livestock)	(14)	11	No		
Manganese		mg/L	0.05	1 ⁽⁹⁾				<0.0020	1	(9)	0.08	No		
Mercury		mg/L	0.0001	0.0002		0.000026		0.00001	0.000026	(7)	<0.0001	No		> than CCME but < than PWQO
Molybdenum		mg/L	0.002		0.04			0.0013	0.04	(6)	0.0013	No		
Nickel		mg/L	0.0005	0.025		0.025-0.15		0.001025	0.025	(4)	0.0013	No		
Potassium		mg/L	0.001				5.3	1.625	5.3	(12)	2.3	No	29%	Toxicity benchmark is modified LCV (Suter and Tsao, 1996)
Selenium		mg/L	0.2	0.1		0.001		0.00013875	0.001	(7)	0.00022	No		
Silicon		mg/L	0.05					0.26	--		1.4	--		
Silver		mg/L	0.002	0.0001		0.0001		<0.0001	0.0001	(4,7)	<0.0001	No		
Sodium		mg/L	0.0001				68	14.5	68	(12)	91	Yes	84%	Toxicity benchmark is modified LCV (Suter and Tsao, 1996)
Strontium		mg/L	0.1				1.5	0.18	1.5	(13)	0.28	No	36%	Toxicity benchmark is SCV (Suter and Tsao, 1996)
Tellurium		mg/L	0.001					<0.0010	<0.0010	(2)	<0.0010	No		
Thallium		mg/L	0.001		0.0003 ⁽³⁾	0.0008		<0.00050	0.0008	(7)	<0.00050	No		
Tin		mg/L	0.00005					<0.0010	<0.0010	(2)	<0.0010	No		
Titanium		mg/L	0.001	1 ⁽⁹⁾				<0.005	1	(9)	0.013	No		
Tungsten		mg/L	0.005		0.03			<0.0010	0.03	(6)	<0.0010	No		
Uranium		mg/L	0.001		0.005 ⁽¹⁾	0.015		0.0003675	0.015	(7)	0.00045	No		
Vanadium		mg/L	0.0001		0.006			<0.0005	0.006	(6)	0.0013	No		
Zinc		mg/L	0.0005	0.03	0.02	0.03		<0.0050	0.02	(6)	0.0074	No		
Zirconium		mg/L	0.005		0.004			<0.0010	0.004	(6)	<0.0010	No		
Iron		mg/L	0.001	0.3		0.3		<0.1	0.3	(4,7)	0.56	Yes		
Petroleum Carb														
Petroleum Hydrocarbons - F1 (C6-C10)-BTE		mg/L	0.025			0.167		<0.025	0.167	(5)	<0.025	No		
Petroleum Hydrocarbons - F1 (C6-C10)		mg/L	0.025			0.167		<0.025	0.167	(5)	<0.025	No		
Petroleum Hydrocarbons - F2 (C10-C16)		mg/L	0.1			0.842		<0.1	0.842	(6)	<0.1	No		
Petroleum Hydrocarbons - F3 (C16-C34)		mg/L	0.2					<0.2	--		<0.2	No		
Petroleum Hydrocarbons - F4 (C34-C50)		mg/L	0.2					<0.2	--		<0.2	No		
Other														
Morpholine		mg/L	0.004		0.004			<0.004	0.004	(6)	<0.004	No		
Radionuclides														
Tritium		Bq/L	4.4	7000				<4.4	7000	(4,8)	16.2	No		
Carbon-14		Bq/L	0.1					<0.1	200	(8)	<0.1	No		Assessed quantitatively for public interest purposes
Cobal-60		Bq/L	0.1					<0.1	2	(8)	<0.1	No		
Cesium-134		Bq/L	0.1					<0.1	7	(8)	<0.1	No		
Cesium-137		Bq/L	0.1					<0.1	10	(8)	<0.1	No		

- Notes:
- Bold and shaded indicates exceedance of selected surface water quality benchmark. Concentrations of parameters that exceeded background by <20% were not identified as exceedances in the
 - Mean background concentration from LWC-1
 - Interim PWQO was set based on readily available information and was not peer reviewed; the CCME guideline is used in preference
 - PWQO Ontario MOE
 - CCME (2008) aquatic protection value calculated for assumed composition of F1 and F2; other PHC fractions considered insufficiently soluble to be of concern as chemical toxicants in v
 - Interim PWQO
 - CCME Surface Water Quality Guideline for Protection of Aquatic Life
 - Ontario Drinking Water Standards (ODWS, 2002)
 - British Columbia, BC MOE (2001) for manganese hardness of 100 mg/L, BC Regs 375/96 (1996) for titanium
 - Federal Water Quality Guideline for Freshwater Life (EC, 201)
 - Maximum value from 2014 Supplementary EMP Study (EcoMetric, 201)
 - LCV from Suter and Tsao (1996) modified to NOEC
 - SCV from Suter and Tsao (1996)
 - MacDonald (1999)

Table A.11: Screening of Frenchman's Bay Sediment COPCs for Ecological Assessment

Analyte	Unit	Detection Limit	Sediment Screening Level	Ref	Max Observed 2015 Sediment	Carried Forward as COPC?	Notes
General Chem							
Total Organic Carbon	µg/g dw	500	1%	(3)	100000	Yes	see Appendix F
Gravel	%	--	--	--	--	No	
Sand	%	--	--	--	--	No	
Silt	%	--	--	--	--	No	
Clay	%	--	--	--	--	No	
Moisture	%	--	--	--	--	No	
Metals/Metalloids							
Aluminum	µg/g dw	50	7908.7	(7)	13000	Yes	see Appendix F
Antimony	µg/g dw	0.2	2	(6)	1.00	No	
Arsenic	µg/g dw	1	5.9	(2)	5	No	
Barium	µg/g dw	0.5	264.3	(7)	110	No	
Beryllium	µg/g dw	0.2	1.17	(7)	0.58	No	
Bismuth	µg/g dw	1	<0.5	(7)	<1.0	Yes	see Appendix F
Boron	µg/g dw	5	7.1	(7)	25	Yes	see Appendix F
Cadmium	µg/g dw	0.1	0.6	(2),(3)	0.75	Yes	see Appendix F
Calcium	µg/g dw	50	107576	(7)	130000	Yes	see Appendix F
Chromium	µg/g dw	1	26	(3)	31	Yes	see Appendix F
Cobalt	µg/g dw	0.1	50	(4)	8	No	
Copper	µg/g dw	0.5	16	(3)	74	Yes	see Appendix F
Iron	µg/g dw	50	21200	(3)	21000	No	
Lead	µg/g dw	1	31	(3)	43	Yes	see Appendix F
Magnesium	µg/g dw	50	10501	(7)	9600	No	
Manganese	µg/g dw	1	460	(3)	660	Yes	see Appendix F
Mercury	µg/g dw	0.05	0.17	(2)	0.08	No	
Molybdenum	µg/g dw	0.5	13.8	(5)	1	No	
Nickel	µg/g dw	0.5	16	(3)	23	Yes	see Appendix F
Phosphorus	µg/g dw	50	600	(3)	1500	Yes	see Appendix F
Potassium	µg/g dw	200	8494	(7)	1900	No	
Selenium	µg/g dw	0.5	1.9	(5)	1.10	No	
Silver	µg/g dw	0.2	0.5	(4)	0.25	No	
Sodium	µg/g dw	50	9154	(7)	590	No	
Strontium	µg/g dw	1	270	(7)	220	No	
Thallium	µg/g dw	0.05	0.17	(7)	0.26	Yes	see Appendix F
Tin	µg/g dw	5	3.01	(7)	5.00	Yes	see Appendix F
Uranium	µg/g dw	0.05	104.4	(5)	0.68	No	
Vanadium	µg/g dw	5	35.2	(5)	29	No	
Zinc	µg/g dw	5	120	(3)	230	Yes	see Appendix F
Radionuclides							
Carbon-14	Bq/kg-C dw	100	--	--	272	No	Assessed quantitatively for public interest purposes
Cobalt-60	Bq/kg dw	1	--	--	<1	No	
Cesium-134	Bq/kg dw	3.3	--	--	<3.3	No	
Cesium-137	Bq/kg dw	1	--	--	3	No	

Notes:
 1. Bold and shaded indicates exceedance of selected sediment quality benchmark. Concentrations of parameters that exceeded background by <20% were not identified as exceedances in the table.
 2. ISQG CCME
 3. LEL Ontario MOE
 4. Open Water Disposal
 5. Thompson et al. 2005
 6. Long, E.R. and L.G. Morgan (1991), NOAA
 7. OPG, 2009 (95th Percentile of Regional Lake Ontario Sediment)

Table A.12: Non-Radiological Screening of Ditch Landfill COPCs for Ecological Assessment - 2012

Parameter	Units	PWQO	Interim PWQO	CCME	Other Jurisdiction	Selected Screening Level	Ref	Max Concentration in Ditch 6	Ditch 6 (2010)	Ditch 6 (2012)	Carried Forward as COPC?
Alkalinity (as CaCO3)	ppm	Variable				-		364	217	364	-
BOD	ppm					-		6.5	6.5	<2	-
DOC	ppm					-		9.8	6	9.8	-
Hardness (as CaCO3)	ppm					-		752	752	587	-
pH	pH Units	6.5-8.5		6.5-8.5		6.5-8.5	(2),(4)	7.75	7.57	7.75	-
TSS	ppm					-		25	25	5.5	-
Calcium	ppm				1000 (livestock) ⁽⁵⁾	1000	(5)	229	229	168	No
Copper	ppm	0.005	0.005	0.004		0.004	(4)	<0.01	0.003	<0.01	No (DL changed in 2012. 2010 less than PWQO)
Phosphorus	ppm		0.02			0.02	(3)	<0.2	0.04	<0.2	No (exceeds PWQO but not considered toxicity issue)
Zinc	ppm	0.03	0.02	0.03		0.02	(2)	<0.005	0.0070	<0.005	No
Phenol	ppm		0.005	0.004		0.004	(4)	<0.002	<0.002	<0.002	No
Sulphate	ppm	830.00	132.00		100 ⁽⁶⁾	100	(6)	328	328.00	245.00	Yes

Notes:

1. Bold and shaded indicates exceedance of selected surface water screening level.
2. PWQO Ontario MOE.
3. Interim PWQO.
4. CCME Surface Water Quality Guideline for Protection of Aquatic Life.
5. MacDonald, 1999 (Livestock)
6. BC MOE (2000) Ambient Water Quality Guidelines for Sulphate. Overview Report. British Columbia Ministry of the Environment

Table A.13: Screening of Soil COPCs for Ecological Risk Assessment

Parameter	Unit	Detection Limit	MOE 2011 (Table 3 - Industrial)	CCME SQG (Industrial)	US EPA Region 5 RCRA	Soil Screening Level	Ref	Max Soil Conc.	Carried Forward as COPC?	Notes
Inorganics										
Conductivity	ms/cm	0.002	1.4			1.4	(1)	1.2	No	
Cyanide (free)	ug/g	0.01	0.051	8	1.3	0.051	(1)	0.33	Yes	
Moisture, Percent	%							20	No	
pH	pH units							8.07	No	
Sodium Adsorption Ratio	-		12	12		12	(1)	11	No	
Metals										
Antimony	ug/g	0.2	40	40		40	(1)	9.7	No	
Arsenic	ug/g	1	18	12		12	(2)	58	Yes	
Barium	ug/g	0.5	670	2000		670	(1)	140	No	
Beryllium	ug/g	0.2	8	8		8	(1)	0.79	No	
Boron	ug/g	5				0	(1)	12	No	
Boron, Hot Water Soluble	ug/g	0.1	2			2	(1)	0.42	No	
Cadmium	ug/g	1	1.9	22		1.9	(1)	1.7	No	
Chromium	ug/g	0.1	160	87		87	(2)	44	No	
Cobalt	ug/g	1	80	300		80	(1)	67	No	
Copper	ug/g	0.5		91		91	(2)	830	Yes	
Hexavalent Chromium	ug/g	0.2	9	1.4		1.4	(2)	<0.2	No	
Lead	ug/g	1	120	600		120	(1)	230	Yes	
Mercury	ug/g	0.05	3.9	50		3.9	(1)	<0.05	No	
Molybdenum	ug/g	0.5	40	40		40	(1)	16	No	
Nickel	ug/g	0.5	270	89		89	(2)	23	No	
Selenium	ug/g	0.5	5.5	2.9		2.9	(2)	2	No	
Silver	ug/g	0.2	40	40		40	(1)	0.53	No	
Thallium	ug/g	0.05	3.3	1		1	(2)	0.22	No	
Uranium	ug/g	0.05	33	300		33	(1)	0.89	No	
Vanadium	ug/g	5	86	130		86	(1)	41	No	
Zinc	ug/g	5	340	360		340	(1)	3200	Yes	
Petroleum Hydrocarbons										
Benzene	ug/g	0.02	0.32			0.32	(1)	< 0.020	No	
Ethylbenzene	ug/g	0.02	9.5			9.5	(1)	< 0.020	No	
Toluene	ug/g	0.05	68			68	(1)	< 0.020	No	
Xylenes, Total	ug/g	0.02	26			26	(1)	< 0.020	No	
Petroleum Hydrocarbons - F1 (C6-C10)	ug/g	10	55			55	(1)	< 10	No	
Petroleum Hydrocarbons - F1 (C6-C10)-BTEX	ug/g	10	55			55	(1)	< 10	No	
Petroleum Hydrocarbons - F2 (C10-C16)	ug/g	10	230			230	(1)	< 10	No	
Petroleum Hydrocarbons - F3 (C16-C34)	ug/g	1000	1700			1700	(1)	1100	No	
Petroleum Hydrocarbons - F4 (C34-C50)	ug/g	1000	3300			3300	(1)	1500	No	
Petroleum Hydrocarbons - F4 Gravimetric	ug/g	1000	3300			3300	(1)	5700	Yes	
Reached Baseline at C50	ug/g					0		-	-	
VOCs										
1,1,1,2-Tetrachloroethane	ug/g	0.05	0.087			0.087	(1)	< 0.050	No	
1,1,1-Trichloroethane	ug/g	0.05	6.1	50		6.1	(1)	< 0.050	No	
1,1,2,2-Tetrachloroethane	ug/g	0.05	0.6	0.6		0.05	(1)	< 0.050	No	
1,1,2-Trichloroethane	ug/g	0.05	0.05	50		0.05	(1)	< 0.050	No	
1,1-Dichloroethane	ug/g	0.05	17	50		17	(1)	< 0.050	No	
1,1-Dichloroethene	ug/g	0.05	0.064	50		0.064	(1)	< 0.050	No	
1,2-Dibromobenzene	ug/g	0.05	0.05			0.05	(1)	< 0.050	No	
1,2-Dichlorobenzene	ug/g	0.05	6.8			6.8	(1)	< 0.050	No	
1,2-Dichloroethane	ug/g	0.05	0.05			0.05	(1)	< 0.050	No	
1,2-Dichloropropane	ug/g	0.05	0.16			0.16	(1)	< 0.050	No	
1,3-Dichlorobenzene	ug/g	0.05	9.8			9.8	(1)	< 0.050	No	
1,3-Dichloropropane, Total	ug/g	0.05	0.18			0.18	(1)	< 0.050	No	
1,4-Dichlorobenzene	ug/g	0.05	0.2	10		0.2	(1)	< 0.050	No	
2-Butanone	ug/g	0.5	70			70	(1)	< 0.50	No	
4-Methyl-2-pentanone	ug/g	0.5	31			31	(1)	< 0.50	No	
Acetone	ug/g	0.5	16			16	(1)	< 0.50	No	
Benzene	ug/g	0.5	0.32			0.32	(1)	< 0.020	No	
Bromodichloromethane	ug/g	0.02	18			18	(1)	< 0.050	No	
Bromoform	ug/g	0.05	0.61			0.61	(1)	< 0.050	No	
Bromomethane	ug/g	0.05	0.05			0.05	(1)	< 0.050	No	
Carbon Tetrachloride	ug/g	0.05	0.21	50		0.21	(1)	< 0.050	No	
Chlorobenzene	ug/g	0.05	2.4			2.4	(1)	< 0.050	No	
Chloroform	ug/g	0.05	0.47	50		0.47	(1)	< 0.050	No	
cis-1,2-Dichloroethane	ug/g	0.05	55			55	(1)	< 0.050	No	
cis-1,3-Dichloropropene	ug/g	0.03	50	0.398		0.398	(3)	< 0.030	No	
Dibromochloromethane	ug/g	0.05	13			13	(1)	< 0.050	No	
Dichlorodifluoromethane	ug/g	0.05	16			16	(1)	< 0.050	No	
Ethylbenzene	ug/g	0.02	9.5			9.5	(1)	< 0.020	No	
Methyl tert-Butyl Ether	ug/g	0.05	11			11	(1)	< 0.050	No	
Methylene Chloride	ug/g	0.05	1.6	50		1.6	(1)	< 0.050	No	
n-Hexane	ug/g	0.05	46			46	(1)	< 0.050	No	
Styrene	ug/g	0.05	34	50		34	(1)	< 0.050	No	
Tetrachloroethane	ug/g	0.05	4.5	0.6		0.6	(2)	< 0.050	No	
Toluene	ug/g	0.02	68			68	(1)	< 0.020	No	
trans-1,2-Dichloroethane	ug/g	0.05	1.3			1.3	(1)	< 0.050	No	
trans-1,3-Dichloropropene	ug/g	0.04			0.398	0.398	(3)	< 0.040	No	
Trichloroethane	ug/g	0.05	0.91			0.91	(1)	< 0.050	No	
Trichlorofluoromethane	ug/g	0.05	4			4	(1)	< 0.050	No	
Vinyl Chloride	ug/g	0.02	0.032			0.032	(1)	< 0.020	No	
Xylenes, Total	ug/g	0.02	26			26	(1)	< 0.020	No	
Semi-VOCs										
1- & 2-Methylnaphthalene	ug/g	0.0071	76			76	(1)	0.018	No	
1-Methylnaphthalene	ug/g	0.005	76			76	(1)	0.0094	No	
2-Methylnaphthalene	ug/g	0.005	76			76	(1)	0.0083	No	
4-Methyl-2-pentanone	ug/g	0.005	31			31	(1)	< 0.50	No	
Acenaphthene	ug/g	0.005	96			96	(1)	< 0.0050	No	
Acenaphthylene	ug/g	0.005	0.15			0.15	(1)	< 0.0050	No	
Anthracene	ug/g	0.005	0.67			0.67	(1)	0.012	No	
Benzo [b,j] fluoranthene	ug/g	0.005	0.96			0.96	(1)	0.11	No	
Benzo[a]anthracene	ug/g	0.005	0.96			0.96	(1)	0.065	No	
Benzo[a]pyrene	ug/g	0.005	0.3			0.3	(1)	0.052	No	
Benzo[k]fluoranthene	ug/g	0.005	9.6			9.6	(1)	0.031	No	
Benzo[k]fluoranthene	ug/g	0.005	0.96			0.96	(1)	0.022	No	
Chrysene	ug/g	0.005	9.6			9.6	(1)	0.064	No	
Dibenzo[a,h]anthracene	ug/g	0.005	0.1			0.1	(1)	0.0066	No	
Fluoranthene	ug/g	0.005	9.6			9.6	(1)	0.17	No	
Fluorene	ug/g	0.005	62			62	(1)	< 0.0050	No	
Indeno[1,2,3-cd]pyrene	ug/g	0.005	0.76			0.76	(1)	0.036	No	
Naphthalene	ug/g	0.005	9.6			9.6	(1)	< 0.0050	No	
Phenanthrene	ug/g	0.005	12			12	(1)	0.068	No	
Pyrene	ug/g	0.005	96			96	(1)	0.12	No	
Styrene	ug/g	0.05	34	50		34	(1)	< 0.050	No	
Diethylene Glycol	mg/kg	10			6200	6200	(4)	< 10	No	
Ethylene Glycol	mg/kg	10		960		960	(2)	< 10	No	
Propylene Glycol	mg/kg	10		insufficient info	100000	100000	(4)	< 10	No	
Total Glycols	mg/kg	10						< 10	No	No toxicity data, non-detect
Radionuclides										
Carbon-14	Bq/kg							-	No	
Carbon-14	Bq/kg-C							567	No	
Cobalt-60	Bq/kg							<1.00	No	
Cesium-134	Bq/kg							<1.00	No	
Cesium-137	Bq/kg							<1.00	No	
Potassium-40	Bq/kg							663	No	Assessed quantitatively for public interest purposes (H-3, C-14, Cs-134, Cs-137, Co-60)
Tritium	Bq/kg							92.4	No	

Notes:
 (1) MOE (2011), Table 3 Standards, Industrial, Coarse soil
 (2) CCME Soil Quality Guidelines, Industrial
 (3) US EPA Region 5 RCRA Ecological Screening Levels, <http://www.epa.gov/Region5/waste/cars/pdfs/ecological-screening-levels-200308.pdf>
 (4) B.C. Reg. 375/96 Contaminated Sites Regulation

Table A.14: Screening of Non-Radiological Air COPCs for Ecological Assessment

Contaminant	CAS No.	Aggregate Emission Rate (g/s)					Max (g/s)	Max 1/2 Hour POI Concentration (µg/m ³) ^a	Concentration in Averaging Period of Screening Level (µg/m ³)	Screening Level (µg/m ³)	Averaging Period	Reference	Carried Forward as COPC?
		2011-1 ^b	2011-2 ^c	2015-1 ^b	2015-2 ^c	Max (g/s)							
2-(2-aminoethoxy) ethanol	929-06-6	5.50E-02	5.50E-02	5.50E-02	5.50E-02	5.50E-02	5.49E-01	0.036	38	Annual	TCEQ, 2015	No	
Acetic Acid	64-19-7	3.33E-01	3.33E-01	3.33E-01	3.33E-01	3.33E-01	3.32E+00	1.124	2500	24 Hour	MOECC AAQC	No	
Acetone	67-64-1	3.36E-02	3.36E-02	3.36E-02	3.36E-02	3.36E-02	3.35E-01	0.113	11800	24 Hour	MOECC AAQC	No	
Ammonia	7664-41-7	2.12E+01	2.12E+01	2.12E+01	2.12E+01	2.12E+01	2.11E+02	71.536	100	24 Hour	MOECC AAQC	No	
Ammonium Hydroxide	1336-21-6	2.14E-03	2.14E-03	2.14E-03	2.14E-03	2.14E-03	2.14E-03	0.001	92	Annual	TCEQ, 2015	No	
Amyl Alcohol	71-41-0	1.07E-04	1.07E-04	1.07E-04	1.07E-04	1.07E-04	1.07E-03	3.61E-04	53200	24 Hour	MOECC AAQC	No	
Carbon monoxide	630-08-0	1.48E+01	2.47E+01	1.48E+01	2.47E+01	2.47E+01	1.45E+02	66.714	15700	8 Hour	MOECC AAQC	No	
Deuterium	7782-39-0	3.17E-07	3.17E-07	3.17E-07	3.17E-07	3.17E-07	3.16E-06	1.07E-06	Not toxic (simple asphyxiant)		TCEQ, 2015 (Hydrogen)	No	
Ethanolamine	141-43-5	1.10E+00	1.10E+00	1.10E+00	1.10E+00	1.10E+00	1.10E+01	0.711	7.00	Annual	TCEQ, 2015	No	
Ethylene	74-85-1	9.53E-02	9.53E-02	9.53E-02	9.53E-02	9.53E-02	9.51E-01	0.322	40	24 Hour	MOECC AAQC	No	
Formic Acid	64-18-6	2.40E-01	2.40E-01	2.40E-01	2.40E-01	2.40E-01	2.39E+00	0.810	500	24 Hour	MOECC AAQC	No	
Glycolic Acid	79-14-1	8.90E-03	8.90E-03	8.90E-03	8.90E-03	8.90E-03	8.88E-02	0.006	25	Annual	TCEQ, 2015	No	
Fuel Oil No. 2	68476-30-2	2.80E-01	2.80E-01	2.80E-01	2.80E-01	2.80E-01	2.79E+00	0.181	100	Annual	TCEQ, 2015	No	
Hexane	110-54-3	7.01E-03	7.01E-03	7.01E-03	7.01E-03	7.01E-03	6.99E-02	0.024	2500	24 Hour	MOECC AAQC	No	
Hydrazine	302-01-2	Replaced in 2015	1.87E-03	1.87E-03	1.87E-03	1.87E-03	1.80E-04	6.9E-04 ^d	6	Annual	EC/HC, 2011	No	
Hydrogen Chloride	7647-01-0	2.14E-02	2.14E-02	2.14E-02	2.14E-02	2.14E-02	2.13E-01	0.072	20	24 Hour	MOECC AAQC	No	
Hydroquinone	123-31-9	8.90E-03	8.90E-03	8.90E-03	8.90E-03	8.90E-03	8.88E-02	0.006	2	Annual	TCEQ, 2015	No	
Isopropyl Alcohol	67-63-0	2.14E-03	2.14E-03	2.14E-03	2.14E-03	2.14E-03	2.13E-02	0.007	7300	24 Hour	MOECC AAQC	No	
Methane	74-82-8	1.61E-03	1.61E-03	1.61E-03	1.61E-03	1.61E-03	1.61E-02	0.005	Not toxic (simple asphyxiant)		TCEQ, 2015	No	
Methanol	67-56-1	6.73E-02	6.73E-02	6.73E-02	6.73E-02	6.73E-02	6.71E-01	0.227	4000	24 Hour	MOECC AAQC	No	
Methylamine	74-89-5	1.40E-01	1.40E-01	1.40E-01	1.40E-01	1.40E-01	1.40E+00	0.091	6.4	Annual	TCEQ, 2015	No	
Methylene Chloride	75-09-2	2.25E-01	2.25E-01	2.25E-01	2.25E-01	2.25E-01	2.24E+00	0.146	44	Annual	MOECC AAQC	No	
Mineral Spirits	N/A	2.14E-03	2.14E-03	2.14E-03	2.14E-03	2.14E-03	2.13E-02	0.007	2600	24 Hour	MOECC AAQC	No	
Morpholine	110-91-8	3.00E+01	3.00E+01	3.00E+01	3.00E+01	3.00E+01	2.99E+02	299.265	780000	1/2 Hour	WHO, 1996	No	
Nitric Acid	7697-37-2	1.07E-02	1.07E-02	1.07E-02	1.07E-02	1.07E-02	1.07E-01	0.036	35	24 Hour	MOECC AAQC	No	
Nitrogen oxides	10102-44-0	5.29E+01	8.53E+01	5.29E+01	8.53E+01	8.53E+01	4.78E+02	161.689	200	24 Hour	MOECC AAQC	No	
Particulate matter	N/A	9.54E-01	4.04E+01	9.54E-01	4.04E+01	4.04E+01	2.42E+01	8.186	30	24 Hour	MOECC AAQC	No	
Phosphoric Acid (as P2O5)	7664-38-2	2.14E-03	2.14E-03	2.14E-03	2.14E-03	2.14E-03	2.13E-02	0.007	7	24 Hour	MOECC AAQC	No	
Polyethylene glycol ether	84133-50-6	8.65E-01	8.65E-01	Removed	Removed	N/A	N/A	N/A	N/A	N/A	N/A	No	
Sodium hypochlorite	7681-52-9	1.19E+00	1.19E+00	1.19E+00	1.19E+00	1.19E+00	1.19E+01	0.770	5	Annual	TCEQ, 2015	No	
Sulphur dioxide	7446-09-5	3.34E+01	4.21E+01	3.34E+01	4.21E+01	4.21E+01	3.33E+02	21.590	65	Annual	MOECC AAQC	No	
Sulphur Hexafluoride	2551-62-4	3.46E-03	3.46E-03	3.46E-03	3.46E-03	3.46E-03	3.45E-02	0.012	600000	24 Hour	MOECC AAQC	No	
Sulphuric Acid	7664-93-9	8.55E-03	8.55E-03	8.55E-03	8.55E-03	8.55E-03	8.53E-02	0.029	5	24 Hour	MOECC AAQC	No	
Toluene	108-88-3	6.41E-05	6.41E-05	6.41E-05	6.41E-05	6.41E-05	6.39E-04	2.16E-04	2000	24 Hour	MOECC AAQC	No	
Total hydrocarbons	N/A	2.73E-01	5.18E+00	2.73E-01	5.18E+00	5.18E+00	7.07E+00	0.458	100	Annual	TCEQ, 2015 (Fuel Oil No. 2)	No	
Trimethylbenzene, 1,2,4-	95-63-6	2.95E+00	2.95E+00	2.95E+00	2.95E+00	2.95E+00	2.94E+01	9.954	220	24 Hour	MOECC AAQC	No	
Xylenes	1330-20-7	2.14E-04	2.14E-04	2.14E-04	2.14E-04	2.14E-04	2.13E-03	0.001	730	24 Hour	MOECC AAQC	No	

Notes:

- ND = No Data, N/A = Not Applicable
- ^a Concentration estimated based dispersion factor at property line of 9.9755 µg/m³ (Golder, 2011; OPG, 2015e).
- ^b Maximum Emission Scenario 1: One Standby Gas Turbine Generating Set -A Side (ER1), two Standby Gas Turbine Generating Sets -B Side (ER2), Base Case sources
- ^c Maximum Emission Scenario 2: Two Standby Gas Turbine Generating Sets B Side (ER2), One S7 MW Combustion Turbine with Associated Generator (ERS7), Base Case sources
- ^d Maximum annual concentration at property boundary (OPG, 2015e)

Appendix B Ecological Receptor Profiles

One of the key considerations, which defines the scope of a risk assessment, is the selection of ecological receptors. In selecting ecological receptors it is important to identify plants and animals that are likely to be most exposed to the effects of the project. As it is not possible to evaluate all ecological species at a site, representative VECs are generally selected based on several criteria as discussed in Section 4.1.1 of the main report.

This appendix details the aquatic and terrestrial ecological receptors (groups or species) selected for the assessment.

B.1 Aquatic Biota

B.1.1 Benthic Invertebrates

Benthic invertebrates live and feed within sediments and provide a sediment to fish pathway link and between aquatic and terrestrial ecosystems. Many species feed on decaying organic matter and thereby form an important link between the decomposer and primary consumer levels. Small crustaceans such as the benthic amphipod *Diporeia* spp. and worms (oligochaetes) have historically dominated the open water benthic communities of Lake Ontario. Representatives of the more environmentally sensitive groups such as Ephemeroptera and Trichoptera are generally rare. Most of the dominant taxa had higher abundances at sites within or close to the thermal plumes than at reference sites. In shallow areas, gastropods and bivalves have low relative abundances presumably due to wave abrasion and/or unsuitable substrates at shallow locations. Appearance of chironomid, amphipod and oligochaete increased in the shallows (1-m depth) in the vicinity of the discharge channels where the algae, *Cladophora*, are present.

Aquatic invertebrates are represented by the benthic invertebrates in the ecological model.

B.1.2 Aquatic Plants

B.1.2.1 Narrow-leaved cattail

The Narrow-leaved Cattail (*Typha angustifolia*) is a native emergent wetland species, growing to over 1 m tall. It is commonly found in the northern hemisphere in marshes, ponds, and ditches (Newmaster *et al.*, 1997). Cattails are a good source of material for nest building. Cattails are used by the Red-winged Blackbird and muskrat for nesting, and as feed for the muskrat.

Narrow-leaved cattail was observed during flora inventories within the PN site as recently as 2015 (OPG, 2016).

B.1.3 Amphibians and Reptiles

Amphibians (class: Amphibia) typically inhabit a wide variety of habitats with most species bridging terrestrial and aquatic ecosystems during their life cycle. Common animals within the class include frogs and salamanders. Amphibians rely on surface water for reproduction as larvae are typically born in water. The young generally undergo metamorphosis from larva with gills to an adult air-breathing form with lungs. With their complex reproductive needs and permeable skins, amphibians are often used as ecological indicators.

Reptiles (class: Reptilia) are cold blooded animals with scales or scutes rather than fur and feathers like mammals and birds. Common animals within the class include turtles, snakes and lizards. Most reptiles are oviparous (egg-laying) but do not require water bodies in which to breed.

B.1.3.1 Northern Leopard Frog

The northern leopard frog (*Lithobates pipiens*) is a medium sized, semi terrestrial frog (family: Ranidae). Breeding typically occurs in permanent and semi-permanent shallow, open wetlands that are typically no deeper than 2.0 m in depth, are neutral pH and lack fish (COSEWIC, 2009). The eggs hatch within a period of 9 days and metamorphosis occurs approximately 60 to 90 days after hatching. During the tadpole stage, which is a sensitive life stage, the exposure of tadpoles and fish to constituents of potential concern (COPCs) is expected to be similar (i.e., gills for breathing, absorption through skin, similar feeding habits).

Northern Leopard frog was observed during terrestrial inventories within the PN site as recently as 2015 (OPG, 2016).

B.1.3.2 Midland Painted Turtle

Midland painted turtle (*Chrysemys picta marginata*) is the most common turtle species in Ontario. There are three sub-species of the midland painted turtle, two of which are found in Ontario. Painted turtles inhabit waterbodies, such as ponds and marshes that provide abundant basking sites and aquatic vegetation. Northern populations of painted turtles may take up to five years to reach sexual maturity. Reproducing females lay eggs in May to early July. Nests are dug in loamy or sandy soils in sunny areas. Hatchlings may emerge in the fall but may overwinter in the nest and emerge the following spring. Painted turtles are opportunistic feeders and eat algae, invertebrates, fish, frogs, carrion and vegetation.

Midland painted turtle was observed during terrestrial inventories within the PN site as recently as 2011 (OPG, 2016).

B.1.4 Fish

B.1.4.1 Alewife

Alewife (*Alosa pseudoharengus*) is a member of the herring family. Alewife are found in Lake Ontario, although there is debate as to whether the alewife population found in Lake Ontario is native or introduced. In their native range, alewives are anadromous; they are quite capable of completing its life cycle in freshwater environments. Adult alewife average about 6 to 7 inches in length in the freshwater variety. Alewives live for about 6 to 7 years and usually begin to reproduce around two years of age. Alewives spawn once a year from late April to early June. Females randomly deposit 10,000 to 12,000 eggs. In less than a week, the young alewives hatch and begin feeding primarily on zooplankton. In the fall, the young alewives make their way back to the sea or into the deep waters of freshwater lakes or rivers. Adult alewives feed on zooplankton, aquatic insects, and small fish (Indiana DNR, n.d.).

Alewife was observed during aquatic inventories within the PN site as recently as 2015 (OPG, 2016).

B.1.4.2 Smallmouth Bass

Smallmouth Bass (*Micropterus dolomieu*) is found in the Great Lakes watershed, St. Lawrence River, and northward beyond Lake Nipissing (Ontario MNR, 2015). It prefers rocky lakes and rivers. Smallmouth Bass concentrate around shoreline rocks and points as well as offshore shoals, often in deep water. Adults have an average weight of 1 to 1.4 kg. Sexual maturity is generally attained in males in their third to fifth year and in females in their fourth to sixth year. Smallmouth Bass spawn in June. Females may lay up to 21,100 eggs. After spawning, the males guard the nest. Larval and young smallmouth bass feed on suspended zooplankton then on small insects and crustaceans following dispersal from nesting territories. Adults eat aquatic insects, large crustaceans, and small fish (Funnell, 2012). Smallmouth Bass is a good natural indicator of a healthy environment

Smallmouth Bass was observed during aquatic inventories within the PN site as recently as 2015 (OPG, 2016).

B.1.4.3 Northern Pike

Northern Pike (*Esox lucius*) is a freshwater species found throughout the northern hemisphere. Pike are found in sluggish streams and shallow, weedy places in lakes, as well as in cold, clear, rocky waters. Pike can grow to large sizes, but typically are 46 to 76 cm in length and weigh 0.9-2.3 kg (DFO, 2013a). Pike reproduce in areas with rich submersible vegetation nearby. Pike are known to spawn in spring when the water temperature first reaches 9°C. After mating, males tend to stay in the area for a few extra weeks. Pike are typically solitary ambush predators. Young pike feed on small invertebrates and quickly move on to bigger prey. When the body length is 4 to 8 cm they start feeding on small fish.

Northern Pike was observed during aquatic inventories within the PN site as recently as 2015 (OPG, 2016).

B.1.4.4 Brown Bullhead

Brown Bullhead (*Ameiurus nebulosus*) is a medium sized member of the catfish family. Brown Bullheads are found in both fresh and brackish waters. They generally inhabit lakes, ponds, impoundments, and low-gradient streams, with shallow water and muddy bottoms. This warm water species is a benthic dweller. It can tolerate lower oxygen levels and higher water temperatures than most other fish species. Brown Bullhead do not migrate seasonally or to breed. Brown Bullheads average 230 to 305 mm in length. A typical adult weighs approximately 454 g but may reach as much as 1.8 kg. Brown Bullheads spawn in the late spring. One or both parents excavate a shallow nest in mud or sandy substrate near the cover of logs, rocks, or vegetation, in water less than 0.6 m deep. Bullheads lay between 2,000 and 10,000 eggs in an adhesive cluster. Both parents guard the eggs and aerate them by fanning, physically stirring them up, and taking them into the mouth and spitting them back out. Larvae stay within the nest under the protection of the parents for their first week. After leaving the nest larvae remain in dense schools until they reach approximately 50 mm. Brown Bullheads are opportunistic nocturnal bottom feeders, consuming a variety of plant, animal, and detrital foods. Juveniles are primarily carnivorous, and feed mostly on invertebrates, as well as eggs and larvae of other fish. Leeches, mollusks, fish eggs, and frogs are also common foods of adults. Brown Bullhead are able to digest and utilize filamentous algae and may consume large amounts of this food source (US EPA, n.d.).

Brown Bullhead was observed during aquatic inventories within the PN site as recently as 2015 (OPG, 2016).

B.1.4.5 Round Whitefish

The Round Whitefish (*Prosopium cylindraceum*) is a coldwater lake fish. Spawning migrations may be undertaken by some Round Whitefish populations. Adults typically weigh between 454 g and 1360 g. Spawning occurs along lake and stream shorelines in late fall or early winter in southern Canada over gravel shoals or river mouths. Round Whitefish are shallow water bottom feeders. Females lay and average of 5,000 to 12,000 eggs. Round Whitefish hatch as sac fry in March to May and remain on the bottom, seeking shelter in rubble and boulders. Older juveniles, age 1 and 2, live in the same areas as adults but in shallower water and tend to move into deeper and faster water as they grow. Round Whitefish eat a variety of invertebrates including mayfly larvae, chironomid larvae, small mollusks, crustaceans, fish, and fish eggs. Fish in lakes may eat more molluscs and small crustaceans than those in rivers (DFO, 2007; IF&W, 2001).

Round Whitefish was observed during aquatic inventories within the PN site as recently as 2012 (OPG, 2016).

B.1.4.6 White Sucker

White Sucker (*Catostomus commersonni*) is a freshwater fish found in lakes and streams across North America. It is a bottom feeding fish that resides mainly in shallow, warm waters. The White Sucker spawns in spring, April or May, in moderate to swift riffles, in gravelly and stony areas, when the water temperature is above 4°C. Spawning may also take place in the shallow water of lakes. Females randomly scatter 30,000 to 130,000 eggs over the spawning grounds. Fry (1.2 cm in length) feed primarily on plankton and other small free-floating invertebrates. When the White Sucker reaches a length of about 1.6 to 1.8 cm, it begins bottom feeding. White Sucker are preyed upon by birds, fishes, lamprey and mammals. In this assessment, white suckers are assumed to spend half of their time at the sediment surface and the other half immersed in the water (Ontario Fish Species, n.d.).

White Sucker was observed during aquatic inventories within the PN site as recently as 2015 (OPG, 2016).

B.1.4.7 Lake Trout

Lake Trout (*Salvelinus namaycush*) is a freshwater char. Lake Trout mainly reside in deep lakes in northern North America where the water is cold and oxygen-rich. In spring, lake trout are widely dispersed in the shallow waters of their habitat but, as soon as the water warms they migrate to deeper and colder water. Adults are generally 38 to 52 cm in length and have an average weight of 4.5 kg. In general, Lake Trout spawn on rocky reefs or shoals in the fall. Spawning takes place at night during which the eggs are scattered over the rocky bottom. The eggs remain among the rocks for weeks and hatch the following spring. Within a month or so after hatching, the young Lake Trout usually seek deeper water and are thought to be reclusive, plankton feeders during their first few years of life. The Lake Trout's diet varies depending on the season; in the summer months they become more planktivorous and during the cooler months, they become piscivorous (DFO, 2013b).

Lake Trout was observed during aquatic inventories within the PN site as recently as 2015 (OPG, 2016).

B.1.4.8 Walleye

Walleye (*Sander vitreus*) is the largest member of the perch family. The Walleye is native to the freshwaters of North America. The Walleye is a cool-water species that prefers turbid waters in either large, shallow lakes or rivers. Adults are generally 33 to 51 cm in length, with an average weight of 0.45 to 1.4 kg. Walleye spawn in the spring or early summer. Adults migrate to the rocky areas in white water below impassable falls and dams in rivers, or boulder to coarse-gravel shoals of lakes. Spawning takes place at night and the eggs fall into crevices in the rocky substrate. The eggs hatch in 12 to 18 days and by 10 to 15 days after hatching, the young disperse into the upper levels of open water. As the Walleye increases in size, its diet shifts from invertebrates to fishes (DFO, 2013c).

Walleye was observed during aquatic inventories within the PN site as recently as 2015 (OPG, 2016).

B.1.4.9 American Eel

The American Eel (*Anguilla rostrata*) is a freshwater species found on the eastern coast of North America, and enter Ontario through the St. Lawrence River and Lake Ontario. The eel has a snake-like body and a dorsal fin that extends from half-way down the length of its back to the underside of its body. At maturity, eel range from 75 to 100 centimetres (cm) in length and weigh one to three kilograms. American Eel have a complex life cycle, which begins with breeding in the Sargasso Sea in the Atlantic Ocean. Young eels migrate to inland streams where they proceed to feed and mature in freshwater bodies for 10 to 25 years, before returning to the Sargasso Sea to spawn. The majority of American Eel found in Ontario are large, highly fecund (egg-laden) females. The eel is an important indicator of ecosystem health, and is a top predator. The American Eel is designated an endangered species and is protected under the Provincial *Endangered Species Act, 2007*. The American Eel is designated as “threatened” under COSEWIC.

American Eel was observed during aquatic inventories within the PN site as recently as 2011 (OPG, 2016).

B.1.5 Aquatic Birds

Birds are mobile receptors that will forage from a large home range. During breeding and rearing of young, the home range is often reduced.

B.1.5.1 Trumpeter Swan

The Trumpeter Swan (*Cygnus buccinator*) is a large bird with white feathers and black legs and feet. Adult males weigh an average of 12 kg. The female is slightly smaller, averaging 10 kg. Trumpeter Swans are found in Canada year round. In winter they congregate in areas where water does not freeze and food is available. Breeding birds select nest sites that are surrounded by water from 10 cm to several metres in depth. They frequently construct their nests on old beaver houses and dams or emergent vegetation even before a site is completely free of ice. Most nests are used year after year, usually by the same pair. A female produces an average of 5 or 6 eggs which she incubates for about 32 days until they hatch. The cygnets grow from approximately 300 g at hatching to approximately 7 kg at fledging. During summer, trumpeters feed on leaves, tubers, and roots of aquatic plants at depths up to 1 m, which they reach by dipping their heads and necks, or by up-ending. The cygnets, or young, feed predominately on insects and other invertebrates for the first few weeks of life but may start feeding on plants before they are two weeks old (EC & CWF, 2013).

Trumpeter Swan was observed during terrestrial inventories within the PN site as recently as 2014 (OPG, 2016).

B.1.5.2 Ring-Billed Gull

The Ring-billed Gull (*Larus delawarensis*) is a medium-sized gull, measuring 45 cm from bill to tail, having a 50-cm wingspan and weighing about 0.7 kg. The Ring-billed Gull is probably the most numerous gull in North America. Ring-billed Gulls nest in colonies of hundreds or thousands of pairs. A small percentage of Canadian Ring-billed Gulls winter on the Great Lakes, usually near open water on lakes Erie and Ontario and the Niagara River. Breeding colonies arrive in Eastern Canada in late February or early March. They lay a clutch of three eggs beginning in April in the Great Lakes area. Ring-billed Gulls incubate their eggs for approximately 25 to 27 days until they hatch. The young generally fledge five to six weeks later. The diet of Ring-billed Gulls is variable. These gulls are opportunistic feeders that readily switch from one type of food to another. During the spawning season they will feed primarily on smelt; after a rain they seek out earthworms; during farmers' ploughing and harvesting seasons they feed on insect larvae and mice. At other times of the year they will feed on carrion, flying insects, and the young of other birds, especially small ducklings (EC & CWF, 2013).

Ring-billed Gull was observed during terrestrial inventories within the PN site as recently as 2015 (OPG, 2016).

B.1.5.3 Common Tern

The Common Tern (*Sterna hirundo*) has a circumpolar range and is strongly migratory. It winters in coastal tropical and subtropical areas and breeds in the northern part of its range. Adults have an average length of 31 to 38 cm and an average weight of 93 to 200 g. Common Terns arrive on northern breeding grounds from late April through mid-May (The Cornell Lab of Ornithology, n.d.(a)). They nest on any flat, poorly vegetated surface close to water. The female lays 1 to 4 eggs. The eggs hatch in around 21 or 22 days and the chicks fledge in 22 to 28 days. Like most terns, this species feeds by plunge-diving for fish. However, it is an opportunistic feeder and molluscs, crustaceans and other invertebrate prey may form a significant part of the diet in some areas (BTO, 2013).

Common Tern was observed during terrestrial inventories within the PN site as recently as 2013 (OPG, 2016).

B.1.5.4 Bufflehead

The Bufflehead (*Bucephala albeola*) is Canada's smallest diving duck. Males average 450 g in weight and females about 340 g. During migration they may carry up to an additional 115 g of fat. Their breeding habitat is small ponds, usually in wooded areas. They are not gregarious and typically occur in groups of 10 birds or fewer. Their summer breeding range is north and west of the Great Lakes. Their Canadian overwinter range includes the west coast and favoured spots around Lake Ontario and the southern coasts of New Brunswick and Nova Scotia. Buffleheads nest in tree cavities. The female lays a clutch of 7 to 11 eggs. Hatching occurs about 30 days later and ducklings remain in the

nest only 24 to 36 hours before being lead to the nearest waterbody. The young may be eaten by pike or other predators. The Buffleheads' main foods are arthropods, mostly insect larvae in freshwater and small crustaceans, such as shrimps, crabs, amphipods, in salt water. In fall they eat many seeds of aquatic plants, and in winter they take small marine snails or freshwater clams in their respective habitats (EC & CWF, 2013).

Bufflehead was observed during terrestrial inventories within the PN site as recently as 2008 (OPG, 2016).

B.1.6 Aquatic Mammals

B.1.6.1 Muskrat

The muskrat (*Ondatra zibethicus*) is a large rodent, measuring approximately 50 cm from tip of the nose to tail, and weighing on average 1 kg. Muskrats exist all over North America, from the Arctic Ocean in the north to the Gulf of Mexico in the south, from the Pacific Ocean in the west to the Atlantic Ocean in the east. Muskrats prefer freshwater marshes, marshy areas of lakes, and slow-moving streams. The preferred water depth in these areas is 1 to 2 m, deep enough not to freeze fully during the winter but shallow enough to allow aquatic vegetation to grow. Muskrats nest in compact mounds of partially dried and decayed plant material such as cattails bulrushes. In winter, muskrats generally occupy lodges that they build through burrowing underneath their mounds (EC & CWF, 2013).

Muskrats mainly feed on aquatic plants such as cattails, bulrushes, horsetails, or pondweeds; however, they prefer cattails. When aquatic plants are unavailable, muskrats are also known to feed on fish, frogs, and clams. Breeding generally occurs in March, April, or May. Birth of the litter usually occurs within 1 month of mating and usually contains 5 to 10 young. Breeding can occur multiple times throughout the season (EC & CWF, 2013).

Muskrat was observed during terrestrial inventories within the PN site as recently as 2013 (OPG, 2016).

B.2 Terrestrial Biota

B.2.1 Earthworms

Earthworms live in soil, and depending on the species they either move vertically or horizontally in different soil layers. Earthworms acquire their nutrition through the organic matter in soil as well as the decomposing remains of other animals. They can devour one third of their own body weight per day.

B.2.2 Terrestrial Plants

B.2.2.1 Pines

Various pines have been observed during terrestrial inventories within the PN site between 2008 and 2011. White Pine and Scots Pine were observed as recently as 2011. Austrian Pine was observed as recently as 2013 (OPG, 2016).

B.2.2.2 Chokecherry

Chokecherry (*Prunus virginiana ssp. virginiana*) is a small tree or shrub growing to approximately 8 m, and is native to North America (Ontario Trees & Shrubs, n.d.). Chokecherries are a food source for birds.

Chokecherry was observed during terrestrial inventories within the PN site as recently as 2015 (OPG, 2016).

B.2.2.3 New England Aster

New England Aster (*Symphotrichum novae-angliae* formerly *Aster novae-angliae*) is a flowering herbaceous perennial plant, growing up to approximately 2 m. It is native to the majority of North America east of the Rocky Mountains, with the exception of parts of the southern United States and far northern Canada (USDA, 2003).

New England Aster was observed during terrestrial inventories within the PN site as recently as 2013 (OPG, 2016).

B.2.2.4 Eastern Hemlock

Eastern Hemlock (*Tsuga canadensis*) is a coniferous tree, growing up to 30 m. It is native to eastern North America. In Canada, the Eastern Hemlock is found from New Brunswick and Nova Scotia to southern Quebec and Ontario (USDA, 2002a).

Eastern Hemlock was observed during terrestrial inventories within the PN site as recently as 2014 (OPG, 2016).

B.2.2.5 Red Ash

Red Ash (*Fraxinus pennsylvanica*) is a medium sized deciduous tree, growing up to 12 to 25 m tall and 60 cm diameter trunk. The Red Ash is native to eastern and central North America, and occurs throughout southern and eastern Ontario (Northern Ontario Plant Database, 2013).

Red Ash was observed during terrestrial inventories within the PN site as recently as 2015 (OPG, 2016).

B.2.2.6 Sandbar Willow

Sandbar Willow (*Salix exigua*) is a deciduous shrub, growing up to 4 to 7 m. The Sandbar Willow is native to North America, primarily in the west. Sandbar Willow provides wood and shelter for a number of birds (USDA, 2002b).

Sandbar Willow was observed during terrestrial inventories within the PN site as recently as 2013 (OPG, 2016).

B.2.3 Terrestrial Birds

B.2.3.1 Red-winged Blackbird

The Red-winged Blackbird (*Agelaius phoeniceus*) is one of the most abundant birds across North America. Adults are approximately 17 to 23 cm in length and weigh 32 to 77 g. Red-winged Blackbird breed in wetlands across. They winter in southern British Columbia, extreme southern Ontario, Nova Scotia and rarely in southern Quebec. Red-winged Blackbirds roost in flocks in all months of the year. In summer, small numbers roost in the wetlands where the birds breed. Winter flocks can be congregations of several million birds, including other blackbird species and starlings. Each morning, the roosts spread out, traveling as far as 50 miles to feed, then re-forming at night. Red-winged Blackbirds build their nests low among vertical shoots of marsh vegetation, shrubs, or trees. Females lay a clutch of 2 to 4 eggs. The eggs hatch within 11 to 13 days, and the young fledge approximately 11 to 14 days later. Red-winged Blackbirds eat mainly insects in the summer and seeds, including corn and wheat, in the winter. Sometimes they feed by probing at the bases of aquatic plants with their bills, prying them open to get at insects hidden inside. In fall and winter they eat weedy seeds such as ragweed and cocklebur as well as native sunflowers and waste grains (EC & CWF, 2013).

Red-winged Blackbird was observed during terrestrial inventories within the PN site as recently as 2015 (OPG, 2016).

B.2.3.2 Red-tailed Hawk

The Red-tailed Hawk (*Buteo jamaicensis*) is likely the most common hawk in North America. Adult males average 45 to 56 cm in length and weigh and average of 690 to 1300 g. Adult females are somewhat larger, averaging 19.7 to 25.6 cm in length and weighing 900 to 1460 g. Red-tailed Hawks occupy just about every type of open habitat on the continent. They typically put their nests in the crowns of tall trees, cliff ledge or on artificial structures such as window ledges and billboard platforms. Females typically lay 1 to 5 eggs. The eggs are incubated for about 28 to 35 days and the young fledge in about 42 to 46 days. Mammals make up the bulk of most Red-tailed Hawk meals. They prey upon voles, mice, wood rats, rabbits, snowshoe hares, jackrabbits, and ground squirrels. The hawks also eat birds, snakes and carrion. Individual prey items can weigh anywhere from less than an ounce to more than 5 pounds (The Cornell Lab of Ornithology, n.d.(b)).

Red-tailed Hawk was observed during terrestrial inventories within the PN site as recently as 2014 (OPG, 2016).

B.2.4 Terrestrial Mammals

B.2.4.1 Red Fox

The Red Fox (*Vulpes vulpes*) is a small mammal, ranges in length between 90 to 112 cm, and weighs approximately 4.54 kg (US EPA, 1993). Red Foxes are found throughout Canada in all provinces and territories. They generally occupy a home range between 4 to 8 km² and reside in a main underground den and one or more other burrows within their home range. The tunnels are up to 10 m long and lead to a chamber 1 to 3 m below surface. Foxes breed between late December and mid-March, and pups are born from March through May, with litter sizes ranging from 1 to 10. Pup-rearing is the primary focus of the Red Fox during spring and early summer. Their diet is predominantly small mammals such as mice and voles, but they also eat insects, fruits, berries, seeds and nuts. Their diet varies with the seasons, eating mainly small mammals in fall and winter, nesting waterfowl in the spring, and insects and berries in the summer (EC & CWF, 2013).

Red Fox was observed during terrestrial inventories within the PN site as recently as 2011 (OPG, 2016).

B.2.4.2 Meadow Vole

The Meadow Vole (*Microtus pennsylvanicus*) is a small herbivorous rodent, measuring 8.9 to 13 cm from head to tail, and weighing between 0.02 to 0.04 kg. The Meadow Vole is found across Canada, Alaska and the northern United States. They can be found mainly in meadows, lowland fields, grassy marshes, and along rivers and lakes. They are also occasionally found in flooded marshes, high grasslands near water, and orchards or open woodland if grassy (US EPA, 1993).

The Meadow Vole breeds throughout the year, but breeding peaks from April to October. Gestation lasts approximately 21 days, with litter sizes ranging from 1 to 9 (NatureServe, 2012). Meadow Voles mainly feed on shoots, grass, and bark. Voles are prey for hawks and owls as well as several mammalian predators such as short-tailed shrews, badgers, and foxes (US EPA, 1993).

Meadow Vole was observed during terrestrial inventories within the PN site as recently as 2013 (OPG, 2016).

B.3 References

British Trust for Ornithology (BTO). 2013. Common Tern *Sterna Hirundo* (Linnaeus, 1795). BirdFacts. Retrieved from, <http://blx1.bto.org/birdfacts/results/bob6150.htm>

- Committee on the Status of Endangered Wildlife in Canada (COSEWIC). 2009. COSEWIC assessment and update status report on the Northern Leopard Frog *Lithobates pipiens*, Rocky Mountain population, Western Boreal/Prairie populations and Eastern populations, in Canada. Committee on the Status of Endangered Wildlife in Canada. Ottawa.
- Environment Canada and Canadian Wildlife Federation (EC & CWF). 2013. Hinterland Who's Who. Retrieved from, <http://www.hww.ca/en/species/>
- Fisheries and Oceans Canada (DFO). 2013a. Ontario Great Lakes Fact Sheets. Northern Pike. Retrieved from, <http://www.dfo-mpo.gc.ca/regions/central/pub/factsheets-feuilletsinfos-ogla-rglo/northernpike-grandbrochet-eng.htm>
- Fisheries and Oceans Canada (DFO). 2013b. Ontario Great Lakes Fact Sheets. Lake Trout. Retrieved from, <http://www.dfo-mpo.gc.ca/regions/central/pub/factsheets-feuilletsinfos-ogla-rglo/laketrout-touladi-eng.htm>
- Fisheries and Oceans Canada (DFO). 2013c. Ontario Great Lakes Fact Sheets. Walleye. Retrieved from, <http://www.dfo-mpo.gc.ca/regions/central/pub/factsheets-feuilletsinfos-ogla-rglo/walleye-dorejaune-eng.htm>
- Fisheries and Oceans Canada (DFO). 2007. Fish life history and habitat use in the Northwest Territories: round whitefish (*Prosopium cylindraceum*). Retrieved from, <http://www.dfo-mpo.gc.ca/Library/332060.pdf>
- Funnell, E. 2012. The Smallmouth Bass in Ontario. Ontario Ministry of Environment. March. Retrieved from, http://www.mnr.gov.on.ca/stdprodconsume/groups/lr/@mnr/@letsfish/documents/document/stdprod_095205.pdf
- Indiana Department of Natural Resources. n.d. Aquatic Invasive Species. Retrieved from, <http://www.in.gov/dnr/files/ALEWIFE.pdf>
- Inland Fisheries and Wildlife (IF&W). 2001. Whitefish Management Plan. Retrieved from, <http://www.maine.gov/tools/whatsnew/attach.php?id=442566&an=1>
- NatureServe. 2012. An Online Encyclopedia of Life. Version 7.1. Retrieved from, <http://www.natureserve.org/explorer/>
- Newmaster, S.G., Harris, A., and Kershaw, L. 1997. Wetland Plants of Ontario. Lone Pine Publishing. Ontario.
- Northern Ontario Plant Database. 2013. Plant Description. *Fraxinus pennsylvanica*. Retrieved from, <http://www.northernontarioflora.ca/description.cfm?speciesid=1000494>

- Ontario Fish Species. n.d. White Sucker. Retrieved from,
<http://www.ontariofishspecies.com/white-sucker.html>
- Ontario Ministry of Natural Resources (OMNR). 2007. State of resources reporting:
American eel in Ontario. February. Available at:
http://www.mnr.gov.on.ca/stdprodconsume/groups/lr/@mnr/@sorr/documents/document/stel02_166010.pdf
- Ontario Ministry of Natural Resources and Forestry (MNR). 2015. Smallmouth Bass.
Retrieved from, <https://www.ontario.ca/page/smallmouth-bass>
- Ontario Power Generation (OPG). 2016. Pickering Nuclear Site Species List – 2015.
Document No. P-LIST-07811-00001. April.
- Ontario Trees & Shrubs. n.d. Chokecherry (*Prunus virginiana*). Retrieved from,
<http://ontariotrees.com/main/species.php?id=2027>
- The Cornell Lab of Ornithology. n.d.(a). Common Tern. Retrieved from,
http://www.allaboutbirds.org/guide/Common_Tern/lifehistory
- The Cornell Lab of Ornithology. n.d.(b). Red-tailed Hawk. Retrieved from,
http://www.allaboutbirds.org/guide/red-tailed_hawk/lifehistory
- United States Department of Agriculture (USDA). 2003. Plant Fact Sheet New England
Aster. Retrieved from, http://plants.usda.gov/factsheet/pdf/fs_syno2.pdf
- United States Department of Agriculture (USDA). 2002a. Plant Guide Eastern Hemlock.
Retrieved from, http://plants.usda.gov/plantguide/pdf/cs_tsca.pdf
- United States Department of Agriculture (USDA). 2002b. Plant Fact Sheet Sandbar Willow.
Retrieved from, http://plants.usda.gov/factsheet/pdf/fs_saex.pdf
- United States Environmental Protection Agency (US EPA). n.d. Retrieved from,
http://www.epa.gov/region1/ge/thesite/restofriver/reports/final_era/B%20-%20Focus%20Species%20Profiles/EcoRiskProfile_brown_bullhead.pdf
- United States Environmental Protection Agency (US EPA). 1993. Wildlife Exposure Factors
Handbook. Document No. EPA/600/R-93/187. December.

Appendix C Limiting Gross Beta/Gamma Radionuclides for Ecological Receptors

Beta and gamma emissions from PN are measured as a gross value, rather than by individual radionuclide. In 2003, a study by the Candu Owners Group (COG, 2003) sought to characterize the effluent from the nuclear power stations. However, it is difficult to assign percentages of gross beta/gamma effluent to individual radionuclides using the information available. Without a thorough understanding of the proportions of radionuclides in composition of the gross beta gamma emissions, it is conservative to choose on radionuclide to be representative of the gross value. In addition, it would be impractical to assess twenty-two radionuclides when one can be chosen to conservatively represent their effects.

To choose the representative radionuclide, a derived release limit was calculated for beta and gamma radionuclides in the PN emission. Since beta/gamma is not a concern in the air pathway for ecological receptors, only the liquid effluents were considered. Derived release limits (DRLs) are calculated to represent the release rate that would cause the aquatic biota in the outfall to receive a dose equal to the aquatic radiation benchmark (9.4 mGy/d) due to releases of a radionuclide to surface water during normal operations in a year.

The radionuclides considered in the determination of the DRLs for gross beta-gamma in water were taken from OPG (2010a and 2010b). The list is as follows: P-32, S-35, Sc-46, Cr-51, Mn-54, Fe-55, Fe-59, Co-60, Sr-90 (Y-90), Zr-95, Nb-95, Ru-106, Sn-113, Sb-124, Sb-125, I-131, Cs-137, Eu-154, Gd-153, Tb-160, Zn-65.

Four receptors were chosen to be representative of those that may be exposed to the effluent at the outfall of PN: fish, bottom-dwelling fish, snail and invertebrate. These receptors were chosen represent the effect on both water and sediment concentrations since they have varied occupancy factors (in water, on sediment and in sediment). The occupancy factors of each receptor are summarized in Table C.1.

Table C.1: Occupancy Factors Assumptions for the Aquatic Biota

Aquatic Biota	OF _s	OF _{ss}	OF _w
Fish			1
Bottom Dwelling Fish		0.25	0.75
Snail	0.5	0.5	
Benthic Invertebrates	1		

C.1 Methodology

Radiation dose to aquatic biota due to the release of waterborne effluents is determined as per CSA N288.6-12 (CSA, 2012). The total radiation dose to biota is the sum of the internal and external dose components for each radionuclide ($D_{int} + D_{ext}$).

$$D_{int} = DC_{int}C_t$$

$$D_{ext} = DC_{ext}[(OF_w + 0.5OF_{ws} + 0.5OF_{ss})C_w + (OF_s + 0.5OF_{ss})C_s]$$

where:

D_{int}	=	internal radiation dose ($\mu\text{Gy/d}$)
D_{ext}	=	external radiation dose ($\mu\text{Gy/d}$)
DC_{int}	=	internal dose coefficient ($(\mu\text{Gy/d})/(\text{Bq/kg})$)
DC_{ext}	=	external dose coefficient ($(\mu\text{Gy/d})/(\text{Bq/kg})$)
C_t	=	whole body tissue concentration (Bq/kg fw)
C_w	=	water concentration (Bq/L)
C_s	=	sediment concentration (Bq/kg fw)
OF_w	=	occupancy factor in water
OF_{ws}	=	occupancy factor at water surface
OF_{ss}	=	occupancy factor at sediment surface
OF_s	=	occupancy factor in sediment

The tissue concentrations (C_t) for the aquatic biota were derived using bioaccumulation factors (BAFs), as follows:

$$C_t = C_m \text{BAF}$$

where:

C_t	=	whole body tissue concentration (Bq/kg fw)
C_m	=	media concentration (Bq/L or Bq/kg)
BAF	=	bioaccumulation factor (L/kg or kg/kg)

By setting the total dose to 9.4 mGy/d, the dose equation above can be rearranged to solve for concentration in water or sediment. The relationship between water concentration and sediment concentration is:

$$C_{s(fw)} = \frac{\theta C_w \rho_w + (1-\theta) C_w K_d \rho_s}{\theta \rho_w + (1-\theta) \rho_s}$$

$$C_{s(dw)} = C_{s(fw)} / f_{dw}$$

$$f_{dw} = \frac{(1-\theta) \rho_s}{\theta \rho_w + (1-\theta) \rho_s}$$

where:

$C_{s(fw)}$	=	concentration in sediment (Bq/kg FW)
C_w	=	concentration in water (Bq/L)
ρ_w	=	density of water (1 kg/L)
θ	=	sediment porosity (unitless)
K_d	=	distribution coefficient (L/kg solid)
ρ_s	=	density of solids (kg/L)

$$C_{s(dw)} = \text{concentration in sediment (Bq/kg DW)}$$

$$f_{dw} = \text{dry weight fraction of sediment (unitless)}$$

The water concentration calculated from the benchmark dose is converted into a DRL by multiplying the water concentration by the average annual release rate (i.e., CCW flow rate). The release rate was assumed to be the average of the annual average flow rates from 2007 to 2011 ($3.02E+12$ L/y).

C.2 Assumptions and Parameters

Bioaccumulation factors (BAFs) relate the COPCs in the environmental media to the concentration in the receptor. The BAFs used in to determine tissue concentration were taken from CSA (2008) and IAEA (2010). These values are summarized in Table C.2.

Table C.2: Bioaccumulation Factors (BAFs) for Aquatic Biota (L/kg fw)

Radionuclide	Fish & Bottom-Dwelling Fish	Snail & Benthic Invertebrate
Co-60	54	110
Cr-51	55	390
Cs-137	3500	99
Eu-154	130	600
Fe-55	240	2800
Fe-59	240	2800
Gd-153	30	1000
I-131	6	10
Mn-54	240	690
Nb-95	300	100
P-32	26000	21000
Ru-106	55	11
S-35	800	100
Sb-124	37	81
Sb-125	37	81
Sc-46	190	1500
Sn-113	3000	590
Sr-90	2	240
Tb-160	410	1000
Y-90	20	1000
Zn-65	5000	1800
Zr-95	7	3000

Notes:

¹ Values from CSA (2008) except Eu-154, Ru-106, Sb-124, Sb-125, Sc-46 and Tb-160 from IAEA (2010)

² Values from IAEA (2010)

Radiation dose coefficients (DCs) for the aquatic biota are shown in Table C.3. These DCs were taken from ICRP (2008) and the ERICA Tool (2011). Surrogate species were used were selected to represent the receptors. The ICRP (2008) Trout was used to represent all fish, the ERICA Tool (2011) gastropod and insect larvae were used for the snail and benthic invertebrate, respectively.

Table C.3: Radiation dose coefficients (DCs) for aquatic biota [($\mu\text{Gy/d}$)/(Bq/kg)]

Radionuclide	All Fish		Snail		Benthic Invertebrate	
	Internal DC	External DC	Internal DC	External DC	Internal DC	External DC
Co-60	5.10E-03	3.10E-02	1.90E-03	3.36E-02	1.90E-03	3.36E-02
Cr-51	1.30E-04	3.80E-04	nd	nd	nd	nd
Cs-137	4.40E-03	6.80E-03	3.36E-03	7.92E-03	3.36E-03	7.92E-03
Eu-154	6.00E-03	1.50E-02	4.08E-03	1.70E-02	4.08E-03	1.70E-02
Fe-55	nd	nd	nd	nd	nd	nd
Fe-59	nd	nd	nd	nd	nd	nd
Gd-153	nd	nd	nd	nd	nd	nd
I-131	3.30E-03	4.60E-03	2.64E-03	5.28E-03	2.64E-03	5.28E-03
Mn-54	1.50E-03	1.00E-02	3.12E-04	1.13E-02	3.12E-04	1.13E-02
Nb-95	1.90E-03	9.30E-03	8.16E-04	1.03E-02	8.16E-04	1.03E-02
P-32	9.40E-03	2.60E-04	8.16E-03	1.49E-03	8.16E-03	1.49E-03
Ru-106	1.90E-02	3.80E-03	1.32E-02	9.36E-03	1.32E-02	9.36E-03
S-35	6.80E-04	4.60E-07	6.72E-04	2.88E-06	6.72E-04	2.88E-06
Sb-124	8.00E-03	2.20E-02	5.04E-03	2.64E-02	5.04E-03	2.64E-02
Sb-125	2.20E-03	5.10E-03	1.51E-03	5.76E-03	1.51E-03	5.76E-03
Sc-46	nd	nd	nd	nd	nd	nd
Sn-113	nd	nd	nd	nd	nd	nd
Sr-90	1.50E-02	5.60E-04	1.27E-02	2.88E-03	1.27E-02	2.88E-03
Tb-160	nd	nd	nd	nd	nd	nd
Y-90	nd	nd	nd	nd	nd	nd
Zn-65	1.10E-03	7.10E-03	nd	nd	nd	nd
Zr-95	2.90E-03	9.00E-03	1.80E-03	1.01E-02	1.80E-03	1.01E-02

Note:

nd indicates that no data were available for the radionuclide and receptor

The sediment distribution coefficients (K_d) used in the environmental partitioning calculations are listed in Table C.4. For COPCs that do not have a sediment K_d in CSA 2008 or IAEA 2010, the soil K_d found in IAEA 2010 was used (for sand where available). The sediment porosity and sediment density at the PN site is assumed to be 0.1 and 1.5 kg/L (for sand) respectively (CSA 2008).

Table C.4: Sediment Distribution Coefficients (L/kg dw)

Radionuclide	Distribution Coefficient (K_d)	Reference
Co-60	4.30E+04	IAEA 2010
Cr-51	6.70E+02	CSA 2008
Cs-137	9.50E+03	IAEA 2010
Eu-154	5.00E+02	IAEA 2010
Fe-55	5.00E+03	IAEA 2010
Fe-59	5.00E+03	IAEA 2010
Gd-153	9.90E+02	CSA 2008
I-131	4.40E+03	IAEA 2010
Mn-54	1.30E+05	IAEA 2010
Nb-95	1.60E+03	CSA 2008
P-32	9.00E+01	CSA 2008
Ru-106	3.20E+04	IAEA 2010
S-35	1.10E+02	CSA 2008
Sb-124	5.00E+03	IAEA 2010
Sb-125	5.00E+03	IAEA 2010
Sc-46	1.40E+03	CSA 2008
Sn-113	1.30E+03	CSA 2008
Sr-90	1.90E+02	IAEA 2010
Tb-160	9.90E+02	CSA 2008
Y-90	1.70E+03	CSA 2008
Zn-65	5.00E+02	IAEA 2010
Zr-95	1.00E+03	IAEA 2010

C.3 Results

Table C.5 summarizes the DRLs per radionuclide for each aquatic receptor. Some of the radionuclides do not have DRLs due to insufficient information for appropriate dose coefficients. This is an uncertainty, since these missing radionuclides may yield a lower limit. However, it is not expected to be an issue. The lowest release limit is for Mn-54 for invertebrates (2.12E+13 Bq/y). Mn-54 is released in very small quantities from PN, which are less than detection limits (COG, 2003), so it is not an appropriate representative of the gross beta/gamma component of the effluent released. The next limiting radionuclide is Co-60 for invertebrates (2.15E+13 Bq/y). Cobalt-60 is released at measurable amounts from PN and due to its low DRL, it will be used to represent gross beta/gamma emissions.

Table C.5: Derived Release Limits per Radionuclide (Bq/y)

Radionuclide	Fish	Bottom Dwelling Fish	Snail	Invertebrate
Co-60	9.45E+16	1.86E+14	2.87E+13	2.15E+13
Cr-51	4.05E+18	7.81E+17		
Cs-137	1.86E+15	1.26E+15	5.48E+14	4.12E+14
Eu-154	3.71E+16	1.74E+16	3.45E+15	2.79E+15
Fe-55	-	-	-	-
Fe-59	-	-	-	-
Gd-153	-	-	-	-
I-131	1.44E+18	1.22E+16	1.78E+15	1.34E+15
Mn-54	7.91E+16	1.91E+14	2.83E+13	2.12E+13
Nb-95	5.08E+16	1.25E+16	2.49E+15	1.87E+15
P-32	1.18E+14	1.19E+14	1.69E+14	1.69E+14
Ru-106	2.75E+16	1.91E+15	1.38E+14	1.04E+14
S-35	5.33E+16	5.33E+16	4.30E+17	4.29E+17
Sb-124	7.14E+16	2.21E+15	3.13E+14	2.35E+14
Sb-125	3.56E+17	9.49E+15	1.43E+15	1.08E+15
Sc-46	-	-	-	-
Sn-113	-	-	-	-
Sr-90	9.66E+17	6.76E+17	8.43E+15	8.13E+15
Tb-160	-	-	-	-
Y-90	-	-	-	-
Zn-65	3.42E+15	4.89E+15	-	-
Zr-95	1.43E+18	2.69E+16	2.33E+15	1.96E+15

Note:

Shaded and bolded cells refer to the lowest estimated DRLs per aquatic receptor.

C.4 References

Canadian Standards Association (CSA). 2012. Environmental risk assessments at Class I nuclear facilities and uranium mines and mills. CSA N288.6-12.

Canadian Standards Association (CSA). 2008. Guidelines for calculating derived release limits for radioactive material in airborne and liquid effluents for normal operation of nuclear facilities. CSA N288.1-08.

CANDU Owners Group (COG). 2003. Characterization of Radionuclide Species in CANDU Effluents (Final Report on Analysis of Samples Received in 2002), Report COG-03-3046, December 2003.

ERICA Tool. 2011. ERICA Assessment Tool version June 2011.

International Atomic Energy Agency (IAEA). 2010. Handbook of Parameter Values for the Prediction of Radionuclide Transfer in Terrestrial and Freshwater Environments. Technical Reports Series No. 472.

International Commission on Radiological Protection (ICRP). 2008. Environmental Protection: The Concept and Use of Reference Animals and Plants. Publication 108.

Appendix D Sample Calculations

Table D.1: Sample Calculation-Urban Resident (Toddler) Exposure and Risk to Morpholine

Environmental Media Concentration		Morpholine		
Water Concentration	A	1.45E-04	mg/L	Table 3.20
Human Exposure Factors (Toddler)				
Drinking Water Intake	B	0.6	L/d	Table 3.16
Days per Week/7 (D2)	C	1	d/d	Table 3.16
Weeks per Year/52 (D3)	D	1	wk/wk	Table 3.16
Body Weight	E	16.5	kg	Table 3.16
RAF _{GITi}	F	1	unitless	Table 3.16
TRV (Acceptable Daily Intake)	G	0.48	mg/kg d	Table 3.25
Human Dose and ILCR				
Ingestion Dose	$H = (A*B*C*D*F)/E$	5.26E-06	mg/kg d	Calculation
HQ	$I = H/G$	1.10E-05	unitless	Calculation

Table D.2: Sample Calculation-Sport Fisher Exposure and Risk to Hydrazine

Environmental Media Concentration		<u>Hydrazine</u>		
Water Concentration	A	2.50E-04	mg/L	Table 3.20
Fish Concentration				
Bioaccumulation Factor (BAF)	B	3.16	L/kg fw	Table 3.22
Tissue Concentration	C=A*B	0.02	mg/kg fw	Calculation
Human Exposure Factors (Adult)				
Fish Ingestion	D	0.111	kg/d	Table 3.16
Years Exposed (D4)	E	30	a	Table 3.16
D _{fish} (days in which consumption occurs)	F	365	d/a	Table 3.16
Body Weight	G	70.7	kg	Table 3.16
Life Expectancy	H	70	years	Table 3.16
RAF _{GITi}	I	1	unitless	Table 3.16
TRV (Oral Slope Factor)	J	3	(mg/kg d) ⁻¹	Table 3.25
Human Dose and ILCR				
Ingestion Dose	$K = (C*D*F*I*E)/G*365*H$	5.32E-07	mg/kg d	Calculation
ILCR	$L = K*J$	1.59E-06	unitless	Calculation

Table D.3: Sample Calculation-Trumpeter Swan Dose and Risk Calculations for Copper

Environmental Media Concentration		<u>Copper</u>		
Water Concentration	A	2.10E-03	mg/L	Table 4.27
Sediment Concentration	B	7.40E+01	mg/kg dw	Table 4.27
Aquatic Plant Concentration				
Bioaccumulation Factor (BAF)	C	3.00E+03	L/kg fw	Table 4.18
Tissue Concentration	D = A*C	6.30E+00	mg/kg fw	Calculation
Trumpeter Swan Exposure Factors				
Water Intake	E	2.94E-01	kg/d	Table 4.16
Sediment Intake	F	1.14E-02	kg dw/d	Table 4.16
Aquatic Plant Intake	G	1.39E+00	kg/d fw	Table 4.16
Body Weight	H	11	kg	Table 4.16
Toxicological Benchmark	I	6.17E+01	mg/kg d	Table 4.39
Trumpeter Swan Dose and HQ				
Ingestion Dose	$J = (E*A+F*B+G*D)/H$	8.71E-01	mg/kg d	Calculation
Hazard Quotient	$K = J/I$	0.01	unitless	Calculation

Table D.4: Sample Calculation-Trumpeter Swan Radiological Dose for Cobalt-60

Environmental Media Concentration		<u>Cobalt-60</u>		
Water Concentration (Co-60)	A	<0.10	Bq/L	Table 4.27
Sediment Concentration (dw)	B	<1.00	Bq/kg dw	Table 4.27
Sediment Porosity	C	0.6	unitless	Section 4.2.2.2
Sediment Density	D	1.5	kg/L	Section 4.2.2.2
Density of Water	E	1	kg/L	Section 4.2.2.2
Dry Weight Fraction of Sediment	$F = (1-C)*D/(C*E+(1-C)*D)$	0.5	kg dw/ kg fw	Calculation
Sediment Concentration (fw)	$G = B*F$	0.5	Bq/kg fw	Calculation
Aquatic Plant Concentration				
Bioaccumulation Factor (BAF)	H	7.90E+02	L/kg fw	Table 4.18
Tissue Concentration	$I = A*H$	7.90E+01	Bq/kg fw	Calculation
Trumpeter Swan Exposure Factors				
Water Intake	J	0.294	kg/d	Table 4.16
Sediment Intake	K	1.14E-02	kg dw/d	Table 4.16
Aquatic Plant Intake	L	1.386	kg/d fw	Table 4.16
Occupancy Factor on Sediment Surface	M	0.5	unitless	Table 4.17
Occupancy Factor in Water	N	0.5	unitless	Table 4.17
Transfer Factor	O	2.70E-01	d/kg fw	Table 4.20
Internal Dose Coefficient	P	5.70E-03	(μ Gy/d)/(Bq/kg)	Table 4.22
External Dose Coefficient on Sediment	Q	1.10E-02	(μ Gy/d)/(Bq/kg)	Table 4.22
External Dose Coefficient in Water	R	3.00E-02	(μ Gy/d)/(Bq/kg)	Table 4.22
Trumpeter Swan Dose				
Tissue Concentration	$S = O*(J*A+K*B+L*I)$	2.96E+01	Bq/kg fw	Calculation
Internal Dose	$T = P*S$	1.69E-01	μ Gy/d	Calculation
External Dose	$U = (Q*M*G)+(R*N*A)$	4.25E-03	μ Gy/d	Calculation
Total Radiological Dose	$V = T + U$	1.73E-01	μ Gy/d	Calculation

Table D.5: Sample Calculation-Meadow Vole Dose and Risk Calculations for Copper

Environmental Media Concentration		<u>Copper</u>		
Water Concentration	A	8.80E-03	mg/L	Table 4.27
Soil Concentration	B	8.30E+02	mg/kg dw	Table 4.27
Terrestrial Plant Concentration				
Bioaccumulation Factor (BAF)	C	1.52E-01	kg dw/kg fw	Table 4.19
Tissue Concentration	D = B*C	1.26E+02	mg/kg fw	Calculation
Vole Exposure Factors				
Water Intake	E	4.70E-03	kg/d	Table 4.16
Soil Intake	F	5.28E-05	kg dw/d	Table 4.16
Terrestrial Plant Intake	G	1.10E-02	kg/d fw	Table 4.16
Body Weight	H	0.0338	kg	Table 4.16
Toxicological Benchmark	I	1.54E+01	mg/kg d	Table 4.38
Vole Dose and HQ				
Ingestion Dose	$J = (E*A+F*B+G*D)/H$	4.24E+01	mg/kg d	Calculation
Hazard Quotient	$K = J/I$	2.8	unitless	Calculation

Table D.6: Sample Calculation-Meadow Vole Radiological Dose for Cobalt-60

Environmental Media Concentration		<u>Cobalt-60</u>		
Water Concentration (Outfall)	A	<0.10	Bq/L	Table 4.27
Soil Concentration	B	<1.00	Bq/kg dw	Table 4.27
Terrestrial Plant Concentration				
Bioaccumulation Factor (BAF)	C	8.93E-03	L/kg fw	Table 4.19
Tissue Concentration	D = B*C	8.93E-03	Bq/kg fw	Calculation
Vole Exposure Factors				
Water Intake	E	4.70E-03	kg/d	Table 4.16
Soil Intake	F	5.28E-05	kg dw/d	Table 4.16
Terrestrial Plant Intake	G	1.10E-02	kg/d fw	Table 4.16
Occupancy Factor on Soil Surface	H	1	unitless	Table 4.17
Transfer Factor	I	6.61E-01	d/kg fw	Table 4.20
Internal Dose Coefficient	J	4.00E-03	(μGy/d)/(Bq/kg)	Table 4.22
External Dose Coefficient on Soil	K	1.20E-02	(μGy/d)/(Bq/kg)	Table 4.22
Vole Dose				
	L =			
Tissue Concentration	I*(E*A+F*B+G*D)	4.10E-04	Bq/kg fw	Calculation
Internal Dose	M = J*L	1.64E-06	μGy/d	Calculation
External Dose	N = K*H*B	1.20E-02	μGy/d	Calculation
Total Dose	O = M+N	1.20E-02	μGy/d	Calculation

Appendix E Assessment of Station Contribution to Observed Concentrations at Frenchman’s Bay

E.1 Introduction and Conceptual Model

Frenchman’s Bay, a provincially significant wetland, is designated an Environmentally Sensitive Area by the TRCA, and is an Aquatic Biology Core Area. Frenchman’s Bay is a habitat for wetland vegetation, mainly cattails, benthic invertebrates, fish, and wildlife. The wetland is located in the northern section of the bay.

Surface water and sediment samples were collected in July 2015 from two general areas in Frenchman’s Bay, the north end and the south end. In each area of Frenchman’s Bay, 10 sediment samples and 3 surface water samples were collected. Water samples were analyzed for alkalinity, ammonia (total and un-ionized), BOD, COD, hardness, pH, conductivity, temperature, TSS, TRC (in-situ), petroleum hydrocarbons (PHC F1 to F4), morpholine, metals, TOC, and radionuclides. Sediment samples were analyzed for particle size, TOC, metals, and radionuclides. Details of the sampling program and results are provided in the main ERA report.

A screening against relevant water and sediment quality guidelines was conducted and the results are discussed in Section 4.1.3.1.3 of the main ERA report, and presented in the Tables A.10 and A.11 in Appendix A. A summary of the COPCs that exceeded water and sediment quality guidelines is provided in Table E.1. The exposure assessment, effects assessment and risk characterization is discussed for all parameters presented in Table E.1. The assessment at Frenchman’s Bay presented in the main ERA report focused on parameters identified as COPCs in lake water samples and Frenchman’s Bay water samples only; however Appendix E provides a full assessment of all COPCs that exceeded water and sediment quality guidelines.

The TOC concentration in sediment exceeds the MOECC guideline. However, it is expected that TOC in wetland locations will frequently exceed the MOECC guideline, since the guideline for TOC is based on a Great Lakes data set, and no wetland guidelines are available. The screening level concentration (SLC) method used by the MOECC is constrained by the range of values in the data set; it cannot yield a higher guideline. Therefore, the TOC guideline is not suitable for wetlands. TOC is not considered a COPC and is not discussed further.

Table E.1: Summary of 2015 Water and Sediment COPCs Exceeding Water Quality Guidelines

Water COPC	Sediment COPC
Total Aluminum	Aluminum
Copper	Bismuth*
Iron	Boron*
Sodium	Cadmium
	Calcium*

Water COPC	Sediment COPC
	Chromium Copper Iron Lead Manganese Nickel Phosphorus Thallium* Tin* Zinc

Note:

* Indicates the parameter exceeds a background concentration. No guideline exists.

The ecological conceptual model for the aquatic environment at Frenchman's Bay is consistent with that presented in the main ERA report, and reproduced in Figure E.1 below.

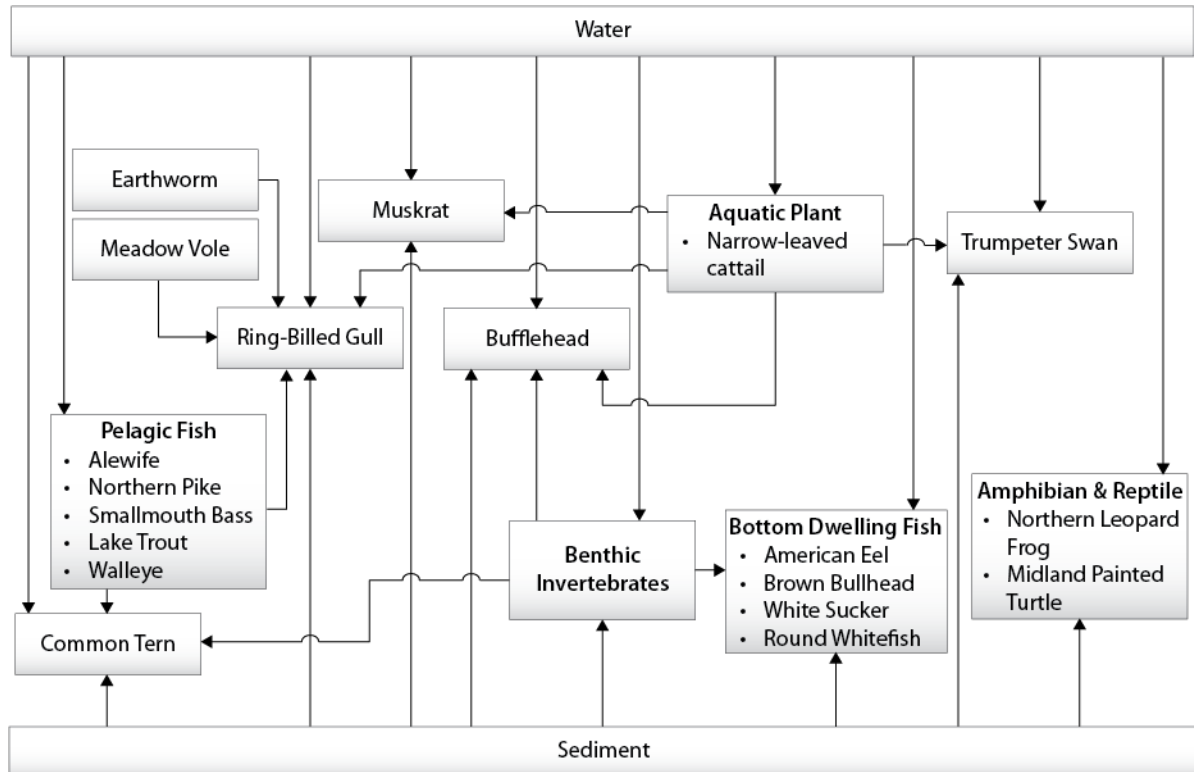

Note:

Riparian birds and mammals (i.e., muskrat) are exposed by air immersion which is not shown in the figure.

Figure E.1: Conceptual Model for the Aquatic Environment

E.2 Exposure Assessment

The exposure assessment for Frenchman's Bay followed the methods described in the exposure assessment in Section 4.2 of the main ERA report. The exposure point concentrations for receptors at Frenchman's Bay are presented in Table E.2. The concentrations reflect maximum and average sediment and water concentrations. The north and south end of the Bay have been assessed together, as there is not much variability in measurements

The exposure concentrations in Table E.2, along with the exposure factors in Section 4.2.3.4, were applied to the equations in Section 4.2.3 in the main ERA report to estimate the dose to birds and mammals (Table E.3).

Table E.2: Exposure Concentrations for Frenchman's Bay Exposure Assessment

Media	VEC Category	COPC	Units	Maximum Concentration	Mean Concentration
Water	Aquatic invertebrate	Aluminum	mg/L	2.70E-01	1.40E-01
	Riparian birds	Bismuth		<1.00E-03	<1.00E-03
	Amphibians	Boron		4.20E-02	3.48E-02
	Riparian mammals	Cadmium		1.00E-05	<1.00E-05
	Aquatic plants	Calcium		6.40E+01	5.00E+01
		Chromium		<5.00E-03	<5.00E-03
		Copper		2.10E-03	1.69E-03
		Iron		5.60E-01	2.84E-01
		Lead		9.20E-04	<6.09E-04
		Manganese		8.00E-02	4.55E-02
		Nickel		1.30E-03	<1.04E-03
		Sodium		9.10E+01	5.70E+01
		Thallium		<5.00E-05	<5.00E-05
		Tin		<1.00E-03	<1.00E-03
		Zinc		7.40E-03	<5.31E-03

Media	VEC Category	COPC	Units	Maximum Concentration	Mean Concentration
Sediment	Aquatic invertebrate	Aluminum	mg/kg	1.30E+04	8.86E+03
	Riparian birds	Bismuth	dw	<1.00E+00	<1.00E+00
	Amphibians	Boron		2.50E+01	7.78E+00
	Riparian mammals	Cadmium		7.50E-01	4.82E-01
	Aquatic plants	Calcium		1.30E+05	9.07E+04
		Chromium		3.10E+01	2.23E+01
		Copper		7.40E+01	4.53E+01
		Iron		2.10E+04	1.61E+04
		Lead		4.30E+01	2.98E+01
		Manganese		6.60E+02	4.39E+02
		Nickel		2.30E+01	1.64E+01
		Phosphorus		1.50E+03	9.84E+02
		Sodium		5.90E+02	3.80E+02
		Thallium		2.60E-01	1.92E-01
		Tin		<5.00E+00	<5.00E+00
	Zinc		2.30E+02	1.65E+02	

Note:

Exposure point concentrations are based on measured data from July 2015.

Table E.3: Estimated Dose for Riparian Birds and Mammals at Frenchman's Bay (mg/kg·d)

COPC		Frenchman's Bay (mg/kg·d)				
		Muskrat	Trumpeter Swan	Bufflehead	Common Tern	Ring-Billed Gull
Aluminum	max	9.97E+01	4.19E+01	4.49E+02	2.20E+01	6.86E+01
	mean	5.70E+01	2.40E+01	2.54E+02	1.28E+01	4.06E+01
Bismuth	max	1.22E-02	5.10E-03	3.87E-02	5.93E-03	1.27E-02
	mean	1.22E-02	5.10E-03	3.87E-02	5.93E-03	1.27E-02
Boron	max	6.60E-02	2.71E-02	2.49E-01	1.72E-02	6.21E-02
	mean	2.26E-02	9.01E-03	7.91E-02	6.02E-03	2.08E-02
Cadmium	max	5.89E-02	2.47E-02	1.49E-02	6.50E-04	1.39E-02
	mean	5.82E-02	2.44E-02	1.23E-02	4.80E-04	1.32E-02
Calcium	max	4.45E+04	1.87E+04	7.60E+03	8.15E+02	1.15E+04
	mean	3.47E+04	1.46E+04	5.83E+03	6.30E+02	8.97E+03
Chromium	max	9.22E-02	3.87E-02	9.71E-01	7.61E-02	1.72E-01
	mean	7.06E-02	2.96E-02	8.85E-01	7.05E-02	1.51E-01
Copper	max	2.07E+00	8.71E-01	9.97E-01	1.13E-01	6.74E-01
	mean	1.63E+00	6.85E-01	6.62E-01	8.19E-02	5.08E-01
Iron	max	5.73E+02	2.41E+02	8.06E+02	4.87E+01	2.32E+02

COPC		Frenchman's Bay (mg/kg·d)				
		Muskrat	Trumpeter Swan	Bufflehead	Common Tern	Ring-Billed Gull
Lead	mean	3.04E+02	1.28E+02	4.63E+02	2.81E+01	1.31E+02
	max	6.31E-01	2.65E-01	4.96E-01	3.26E-02	2.10E-01
Manganese	mean	4.21E-01	1.77E-01	3.41E-01	2.24E-02	1.42E-01
	max	1.07E+02	4.50E+01	3.86E+01	3.32E+00	2.64E+01
Nickel	mean	6.12E+01	2.57E+01	2.26E+01	1.93E+00	1.51E+01
	max	7.73E-02	3.25E-02	2.73E-01	1.94E-02	6.68E-02
Phosphorus	mean	5.70E-02	2.39E-02	1.99E-01	1.43E-02	4.87E-02
	max	3.71E+00	1.56E+00	1.48E+01	9.53E-01	4.13E+00
Sodium	mean	2.44E+00	1.02E+00	9.68E+00	6.25E-01	2.71E+00
	max	5.02E+02	2.09E+02	3.01E+02	9.91E+01	2.69E+02
Thallium	mean	3.14E+02	1.31E+02	1.89E+02	6.21E+01	1.69E+02
	max	9.01E-01	3.78E-01	1.16E-01	1.90E-02	2.09E-01
Tin	mean	9.00E-01	3.78E-01	1.15E-01	1.90E-02	2.08E-01
	max	4.25E-02	1.78E-02	2.54E-01	3.54E-01	5.45E-01
Zinc	mean	4.25E-02	1.78E-02	2.54E-01	3.54E-01	5.45E-01
	max	3.68E+00	1.54E+00	7.19E+00	4.55E+00	9.52E+00
	mean	2.64E+00	1.11E+00	5.16E+00	3.27E+00	6.84E+00
	max					

Note:

Doses are based on measured water and sediment data from July 2015.

E.3 Effects Assessment

All aquatic benchmarks are summarized in Table E.4, and were generally Lowest Chronic Values (LCVs) obtained from Suter and Tsao (1996). Borgmann *et al.* (2005) performed acute toxicity tests with *Hyaella azteca* for 63 metals in hard and soft water. Acute LC₅₀ values for boron and bismuth were taken from Borgmann *et al.* (2005) and converted to chronic EC_{20S} (using a conversion factor of 10 (EC/HC, 2003)). For assessment of benthic invertebrates, toxicity benchmarks have been presented as water concentrations; however, benthic invertebrates may reside in the water column and in sediment. As such, sediment toxicity benchmarks are presented for COPCs with MOECC LELs or CCME ISQGs for assessment of benthic invertebrates (Table E.5).

The benchmark values for riparian birds and mammals are based on doses. The benchmark doses used were generally the lowest observed adverse effect level (LOAEL) values from Sample *et al.* (1996). The mammal and bird benchmarks used are summarized in Table E.6 and E.7, respectively.

Major ions (Ca, Mg, Na) were considered to be essentially non-toxic for birds and mammals. They are effectively regulated in the body and have not been associated with adverse effects in birds and mammals at environmental concentrations. Phosphorus was also considered to be essentially non-toxic. It exists in the environment as phosphate, where it acts as a nutrient, and has not been associated with adverse effects in birds and mammals.

Table E.4: Toxicological Benchmarks for Aquatic Receptors

COPC	Receptor	Water TRV (mg/L)	Endpoint	Test Species	Reference
Aluminum	Fish and Frog	3.29E+00	LCV	28-day embryo-larval tests with <i>Pimephales promelas</i>	Kimball, n.d. (cited in Suter and Tsao, 1996)
	Aquatic Plant	4.60E-01	LCV	4-day <i>Selenastrum capricornutum</i>	EPA, 1988 (cited in Suter and Tsao, 1996)
	Benthic Invertebrate	1.90E+00	LCV	<i>Daphnia magna</i>	McCauley et al., 1986 (cited in Suter and Tsao, 1996)
Bismuth	Fish and Frog	none			
	Aquatic Plant	7.2	LOEC	<i>Chlorella vulgaris</i>	den Dooren de Jong, 1965 (cited in Alpine 2010)
Boron	Fish and Frog	1.34	LOEC	28-day embryo survival with rainbow trout <i>Oncorhynchus mykiss</i>	Black et al., 1993 (cited in CCME 2009)
	Aquatic Plant	3.5	LOEC	duckweed (<i>Spirodella polyrrhiza</i>)	Davis et al., 2002 (cited in CCME, 2009)
	Benthic Invertebrate -	8.83	LCV	21-day test with <i>Daphnia magna</i>	Lewis and Valentine, 1981 (cited in Suter and Tsao, 1996)
Cadmium	Fish and Frog	1.70E-03	LCV	Early life stage test with <i>Salvelinus fontinalis</i>	Sauter et al., 1976 (cited in Suter and Tsao, 1996)
	Aquatic Plant	2.00E-03	LCV	-	Conway, 1977 (cited in Suter and Tsao, 1996)
	Benthic Invertebrate	1.50E-04	LCV	Reproduction with <i>Daphnia magna</i>	Chapman et al., n.d. (cited in Suter and Tsao, 1996)
Calcium	Fish and Frog	none			
	Aquatic Plant	none			
Chromium	Fish and Frog	6.83E-02	LCV	21-day test with <i>Daphnia magna</i>	Biesinger and Christensen, 1972 (cited in Suter and Tsao, 1996)
	Fish and Frog	6.83E-02	LCV	Early life stages with Rainbow trout	Stevens and Chapman, 1984 (cited in Suter and Tsao, 1996)
	Aquatic Plant	3.97E-01	LCV	4-day growth inhibition test with <i>Selenastrum capricornutum</i>	EPA, 1985 (cited in Suter and Tsao, 1996)
Copper	Benthic Invertebrate	4.40E-02	LCV	Life-cycle test with <i>Daphnia magna</i>	Chapman et al., n.d. (cited in Suter and Tsao, 1996)
	Fish and Frog	3.80E-03	LCV	Early life stage test with brook trout (<i>Salvelinus fontinalis</i>)	Sauter et al., 1976 (cited in Suter and Tsao, 1996)

COPC	Receptor	Water TRV (mg/L)	Endpoint	Test Species	Reference
	Aquatic Plant	2.00E-03	Water quality guideline	-	CCME, 1999
	Benthic Invertebrate	6.07E-03	LCV	<i>Gammarus pseudolimnaeus</i>	Arthur and Leonard, 1970, (cited in Suter and Tsao, 1996)
Iron	Fish and Frog	1.30E+00	LCV	Mortality with Rainbow Trout	Amelung, 1981 (cited in Suter and Tsao, 1996)
	Aquatic Plant	1.49E+00	EC50 converted to EC20	Growth with <i>Lemna minor</i>	Wang, 1986 (cited in BC MOE, 2008)
	Benthic Invertebrate	3.00E-01	Water quality guideline	-	CCME, 1999
Lead	Fish and Frog	1.89E-02	LCV	Early life stage with rainbow trout	Davies et al., 1976 (cited in Suter and Tsao, 1996)
	Aquatic Plant	5.00E-01	LCV	Growth inhibition with <i>Chlorella vulgaris</i> , <i>Scenedesmus quadricauda</i> , and <i>Selenastrum capricornutum</i>	EPA, 1985 (cited in Suter and Tsao, 1996)
	Benthic Invertebrate	2.55E-02	LCV	21-day test with <i>Daphnia magna</i>	Chapman et al. (manuscript), (cited in Suter and Tsao, 1996)
Manganese	Fish and Frog	1.78E+00	LCV	28-day early life-stage test with <i>Pimephales promelas</i>	Kimball, n.d. (cited in Suter and Tsao, 1996)
	Aquatic Plant	4.98	EC50 converted to EC20	12-day population effects on the green algae (<i>Scenedesmus quadricauda</i>)	Fargasova et al., 1999
	Benthic Invertebrate	1.10E+00	LCV		Kimball, n.d. (cited in Suter and Tsao, 1996)
Nickel	Fish and Frog	3.50E-02	LCV	Early life stage test on rainbow trout	Nebeker et al., 1985 (cited in Suter and Tsao, 1996)
	Aquatic Plant	5.00E-03	LCV	Inhibition with <i>Microcystis aeruginosa</i>	EPA, 1986 (cited in Suter and Tsao, 1996)
	Benthic Invertebrate	1.28E-01	LCV	Life cycle test with <i>Daphnia magna</i>	Lazareva, 1985 (cited in Suter and Tsao, 1996)
Phosphorus	Fish and Frog	0.0017	LC50 converted to EC20	26-day LC50 with Channel fish (<i>Ictalurus punctatus</i>)	Bentley et al., 1978
	Aquatic Plant	3	LOEC	21-day population effects with the Blue-Green Algae	Qiu et al., 2013.
	Benthic Invertebrate	0.004	LC50 converted to EC20	8-day mortality test with <i>Daphnia magna</i>	Bentley et al., 1978
Sodium	Fish and Frog	1.15E+02	EC ₁₀ (Na component of Na ₂ SO ₄)	Developmental effects on <i>Oncorhynchus mykiss</i>	Elphick et al, 2011
	Aquatic Plant	1.71E+02	EC ₂₅ (Na component of Na ₂ SO ₄)	Growth of <i>Fontinalis antipyretica</i>	Elphick et al, 2011

COPC	Receptor	Water TRV (mg/L)	Endpoint	Test Species	Reference
	Benthic Invertebrate	6.80E+02	LCV	Reproductive effects on <i>Daphnia magna</i>	Biesinger and Christensen, 1972 (cited in Suter and Tsao, 1996)
Thallium	Fish and Frog	5.70E-02	LCV	Embryo-larval tests with <i>Pimephales promelas</i>	Kimball, n.d. (cited in Suter and Tsao, 1996)
	Aquatic Plant	1.00E-01	LCV	4-day EC50 with <i>Selenastrum capricornutum</i>	EPA, 1978 (cited in Suter and Tsao, 1996)
	Benthic Invertebrate	1.30E-01	LCV	28-day tests with <i>Daphnia magna</i>	Kimball, n.d. (cited in Suter and Tsao, 1996)
Tin	Fish and Frog	none			
	Aquatic Plant	none			
	Benthic Invertebrate	3.50E-01	LCV	21-day reproductive test with <i>Daphnia magna</i>	Biesinger and Christensen (1972).
Zinc	Fish and Frog	3.64E-02	LCV	Life-cycle tests with <i>Jordanella floridae</i>	Spehar, 1976 (cited in Suter and Tsao, 1996)
	Aquatic Plant	3.00E-02	LCV	7-day growth tests with <i>Selenastrum capricornutum</i>	Bartlett et al., 1974 (cited in Suter and Tsao, 1996)
	Benthic Invertebrate	5.24E+00	LCV	Life-cycle tests with <i>Daphnia magna</i> .	Chapman et al., n.d. (cited in Suter and Tsao, 1996)

Table E.5: Toxicological Benchmarks for Benthic Invertebrates

COPC	Benthic Invertebrate (mg/kg dw)	Reference
Cadmium	0.6	Sediment LEL (MOE, 2011)
Chromium	26	Sediment LEL (MOE, 2011)
Copper	16	Sediment LEL (MOE, 2011)
Iron	21200	Sediment LEL (MOE, 2011)
Lead	31	Sediment LEL (MOE, 2011)
Manganese	460	Sediment LEL (MOE, 2011)
Nickel	16	Sediment LEL (MOE, 2011)
Phosphorus	600	Sediment LEL (MOE, 2011)
Zinc	120	Sediment LEL (MOE, 2011)

Table E.6: Selected Toxicity Reference Values for Mammals (Riparian and Terrestrial)

COPC	Mammal LOAEL (mg/kg-d)	Test Species	Endpoint	Test Duration	Reference
Aluminum	1.93E+01	mouse	reproduction	3 generations	Ondreicka et al., 1966 (cited in Sample et al., 1996)
Bismuth	none				
Boron	9.36E+01	rat	reproduction	3 generations	Weir and Fisher, 1972 (cited in Sample et al., 1996)
Cadmium	1.00E+01	rat	reproduction	6 weeks	Sutou et al., 1980 (cited in Sample et al., 1996)
Chromium	2737 (NOAEL)	rat	reproduction/longevity	2 years	Ivankovic and Preussmann, 1975 (cited in Sample et al., 1996)
Copper	1.51E+01	mink	reproduction	375 days	Aulerich et al., 1982 (cited in Sample et al., 1996)
Iron	none				
Lead	8.00E+01	rat	reproduction	3 generations	Azar et al., 1973 (cited in Sample et al., 1996)
Manganese	2.84E+02	rat	reproduction	critical life stage (224 days)	Laskey et al., 1982 (cited in Sample et al., 1996)
Nickel	80	rat	reproduction	3 generations	Ambrose et al., 1976 (cited in Sample et al., 1996)
Thallium	7.40E-02	rat	reproduction	60 days (critical life stage)	Formigli et al., 1986 (cited in Sample et al., 1996)
Tin	35	mouse	reproduction	days 6 - 15 of gestation	Davis et al., 1987 (cited in Sample et al., 1996)
Zinc	3.20E+02	rat	reproduction	days 1-16 of gestation	Schlicker and Cox, 1968 (cited in Sample et al., 1996)

Table E.7: Selected Toxicity Reference Values for Riparian and Terrestrial Birds

COPC	Bird LOAEL (mg/kg-d)	Test Species	Endpoint	Test Duration	Reference
Aluminum	1.10E+02	ringed dove	reproduction	4 months	Carriere et al., 1986 (cited in Sample et al., 1996)
Bismuth	none				
Boron	1.00E+02	mallard	reproduction	3 wks prior to, during, and 3 wks post reproduction	Smith and Anders, 1989 (cited in Sample et al., 1996)
Cadmium	2.00E+01	mallard	reproduction	critical life stage (90 days)	White and Finley, 1978 (cited in Sample et al., 1996)
Chromium	5.00E+00	black duck	reproduction	critical life stage (10 months)	Haseltine et al., unpubl. Data, (cited in Sample et al., 1996)
Copper	6.17E+01	1 day old chicks	growth, mortality	10 weeks	Mehring et al., 1960 (cited in Sample et al., 1996)
Iron	none				
Lead	1.13E+01	Japanese quail	reproduction	12 weeks	Edens et al., 1976 (cited in Sample et al., 1996)

COPC	Bird LOAEL (mg/kg-d)	Test Species	Endpoint	Test Duration	Reference
Manganese	977 (NOAEL)	Japanese quail	growth, aggressive behaviour	75 days	Laskey and Edens, 1985 (cited in Sample et al., 1996)
Nickel	107	mallard duckling	growth/ mortality	90 days	Cain and Pafford, 1981 (cited in Sample et al., 1996)
Thallium	none				
Tin	16.9	Japanese quail	reproduction	6 weeks	Schlatterer et al., 1993 (cited in Sample et al., 1996)
Zinc	1.31E+02	white leghorn hens	reproduction	44 weeks	Stahl et al., 1990 (cited in Sample et al., 1996)

E.4 Risk Characterization

Ecological risk is estimated by dividing the exposure value (EV) by the benchmark value (BV) for a given COPC and receptor species, yielding a hazard quotient (HQ). When the EV for an organism at a site exceeds the BV (HQ > 1), a potential for adverse ecological effects is inferred. A summary of HQs for aquatic receptors at Frenchman's Bay is presented in Table E.8. The HQs greater than 1 are presented in bold. Toxicity benchmarks are not available for a number of COPCs. HQs have not been calculated for those COPCs and are shown in the table as 'nd' for no data.

Based on the results for Frenchman's Bay, aluminum and thallium exceed an HQ of 1 for muskrats; aluminum exceeds an HQ of 1 for the Bufflehead; copper exceeds an HQ of 1 for aquatic plants; and iron exceeds an HQ of 1 for benthic invertebrates. Sediment concentrations exceed sediment toxicity benchmarks for benthic invertebrates for the majority of metals including: cadmium, chromium, copper, lead, manganese, nickel, phosphorus, and zinc. Exceedances of toxicity benchmarks are not uncharacteristic for an area such as Frenchman's Bay that is highly influenced by urban runoff.

The following section estimates the contribution to risk at Frenchman's Bay for substances released from the PN site.

Table E.8: Hazard Quotients for Aquatic and Riparian Biota at Frenchman's Bay

Parameter		Fish	Frog (Tadpole)	Benthic Invertebrate	Aquatic Plant	Muskrat	Trumpeter Swan	Bufflehead	Common Tern	Ring-Billed Gull
Aluminum	max	0.1	0.1	0.1	0.6	5.2	0.4	4.1	0.2	0.6
	mean	0.0	0.0	0.1	0.3	3.0	0.2	2.3	0.1	0.4
Bismuth	max	nd	nd	0.4	0.0	nd	nd	nd	nd	nd
	mean	nd	nd	0.4	0.0	nd	nd	nd	nd	nd
Boron	max	0.0	0.0	0.0	0.0	0.0	0.0	0.0	0.0	0.0
	mean	0.0	0.0	0.0	0.0	0.0	0.0	0.0	0.0	0.0
Cadmium	max	0.0	0.0	0.1	0.0	0.0	0.0	0.0	0.0	0.0
	mean	0.0	0.0	0.1	0.0	0.0	0.0	0.0	0.0	0.0
Calcium	max	nd	nd	0.6	nd	N/A	N/A	N/A	N/A	N/A
	mean	nd	nd	0.4	nd	N/A	N/A	N/A	N/A	N/A
Chromium	max	0.1	0.1	0.1	0.0	0.0	0.0	0.2	0.0	0.0
	mean	0.1	0.1	0.1	0.0	0.0	0.0	0.2	0.0	0.0
Copper	max	0.6	0.6	0.3	1.1	0.1	0.0	0.0	0.0	0.0
	mean	0.4	0.4	0.3	0.8	0.1	0.0	0.0	0.0	0.0
Iron	max	0.4	0.4	1.9	0.4	nd	nd	nd	nd	nd
	mean	0.2	0.2	0.9	0.2	nd	nd	nd	nd	nd
Lead	max	0.0	0.0	0.0	0.0	0.0	0.0	0.0	0.0	0.0
	mean	0.0	0.0	0.0	0.0	0.0	0.0	0.0	0.0	0.0
Manganese	max	0.0	0.0	0.1	0.0	0.4	0.0	0.0	0.0	0.0
	mean	0.0	0.0	0.0	0.0	0.2	0.0	0.0	0.0	0.0
Nickel	max	0.0	0.0	0.0	0.3	0.0	0.0	0.0	0.0	0.0
	mean	0.0	0.0	0.0	0.2	0.0	0.0	0.0	0.0	0.0
Phosphorus	max	0.0	0.0	0.0	0.0	N/A	N/A	N/A	N/A	N/A
	mean	0.0	0.0	0.0	0.0	N/A	N/A	N/A	N/A	N/A
Sodium	max	0.8	0.8	0.1	0.5	N/A	N/A	N/A	N/A	N/A

Parameter		Fish	Frog (Tadpole)	Benthic Invertebrate	Aquatic Plant	Muskrat	Trumpeter Swan	Bufflehead	Common Tern	Ring-Billed Gull
	mean	0.5	0.5	0.1	0.3	N/A	N/A	N/A	N/A	N/A
Thallium	max	0.0	0.0	0.0	0.0	12.2	nd	nd	nd	nd
	mean	0.0	0.0	0.0	0.0	12.2	nd	nd	nd	nd
Tin	max	nd	nd	nd	nd	0.0	0.0	0.0	0.0	0.0
	mean	nd	nd	nd	nd	0.0	0.0	0.0	0.0	0.0
Zinc	max	0.2	0.2	0.0	0.2	0.0	0.0	0.1	0.0	0.1
	mean	0.1	0.1	0.0	0.2	0.0	0.0	0.0	0.0	0.1

Note:

Bold and shaded values indicate a HQ > 1

nd = no data

The HQs for thallium are equivalent since data are based on non-detects.

E.4.1 Discussion of PN Contribution

A surface water model has been prepared, based on current and temperature data from 2011 and 2012, to predict water concentrations at the inlet to Frenchman's Bay and Ajax WTP based on a tracer concentration for any contaminant of 1 mg/L (Golder and EcoMetrix, 2017). A mass-balance model has also been used to predict concentrations in Frenchman's Bay, assuming a completely mixed embayment, with inputs from lake exchange and tributaries. Based on the surface water model and mass balance model, the dilution factors for PN U1-4 and U5-8 releases at the inlet to Frenchman's Bay and inside the bay are approximately 7 and 9 respectively. Water and sediment samples were collected from north and south ends of Frenchman's Bay. The data have been pooled together as there is not much variability in measurements.

Water samples were collected from the PN discharge channels during July and August 2015 as part of the baseline environmental monitoring program. A dilution factor of 9 was applied to the maximum and mean water concentrations from the discharge channels in order to determine the expected concentration inside Frenchman's Bay due to releases from PN. Table E.9 presents the comparison between measured water concentrations at Frenchman's Bay and estimated water concentrations at Frenchman's Bay based on water concentrations in the PN discharge channels and a dilution factor of approximately 9 to inside Frenchman's Bay. The percent contribution from PN ranges from 0.3% to 22%. Overall, the contribution to the total concentration of metals at Frenchman's Bay from PN is low. Table E.10 summarizes the HQs to receptors at Frenchman's Bay for the PN component of risk. Overall, all HQs for the PN component are below 1 with the exception of thallium for muskrats where the HQ is slightly above 1. The acceptable risk level (HQ) for thallium is exceeded due to sediment ingestion for the muskrat. Contribution from PN to Frenchman's Bay sediment was assumed to be equal to that of water; however, for some parameters such as thallium, water concentrations were below the detection limit; therefore, the contribution from PN may be overestimated.

Table E.9: Measured Water Concentrations at Frenchman's Bay Compared to PN Contribution

COPC	Frenchman's Bay Measured Concentration (mg/L)		Pickering Measured Concentration (mg/L)		Estimated Pickering Contribution at Frenchman's Bay (mg/L)		% Contribution from PN	
	Max	Mean	Max	Mean	Max	Mean	Max %	Mean %
Aluminum	2.70E-01	1.40E-01	9.60E-03	7.27E-03	1.12E-03	8.46E-04	0.41%	0.60%
Bismuth	1.00E-03	1.00E-03	<0.001	<0.001	1.16E-04	1.16E-04	11.64%	11.64%
Boron	4.20E-02	3.48E-02	2.7E-02	2.49E-02	3.14E-03	2.89E-03	7.48%	8.31%
Cadmium	1.00E-05	1.00E-05	1.90E-05	<0.000010	2.21E-06	1.15E-06	22.12%	11.47%
Calcium	6.40E+01	5.00E+01	3.50E+01	3.39E+01	4.07E+00	3.94E+00	6.37%	7.88%
Chromium	5.00E-03	5.00E-03	<0.0050	<0.0050	5.82E-04	5.82E-04	11.64%	11.64%
Copper	2.10E-03	1.69E-03	2.00E-03	1.31E-03	2.33E-04	1.53E-04	11.09%	9.05%
Iron	5.60E-01	2.84E-01	1.00E-01	1.00E-01	1.16E-02	1.16E-02	2.08%	4.10%
Lead	9.20E-04	6.09E-04	<0.0005	<0.0005	5.82E-05	5.82E-05	6.33%	9.56%
Manganese	8.00E-02	4.55E-02	<0.0020	<0.0020	2.33E-04	2.33E-04	0.29%	0.51%
Nickel	1.30E-03	1.04E-03	1.20E-03	1.06E-03	1.40E-04	1.23E-04	10.74%	11.83%
Sodium	9.10E+01	5.70E+01	1.40E+01	1.40E+01	1.63E+00	1.63E+00	1.79%	2.86%
Thallium	5.00E-05	5.00E-05	<0.000050	<0.000050	5.82E-06	5.82E-06	11.64%	11.64%
Tin	1.00E-03	1.00E-03	<0.0010	<0.0010	1.16E-04	1.16E-04	11.64%	11.64%
Zinc	7.40E-03	5.31E-03	5.50E-03	2.07E-03	6.40E-04	5.90E-04	8.65%	11.12%

Table E.10: PN Component of Hazard Quotients for Aquatic Biota at Frenchman's Bay

COPC		Fish	Frog (Tadpole)	Benthic Invertebrate	Aquatic Plant	Muskrat	Trumpeter Swan	Bufflehead	Common Tern	Ring-Billed Gull
Aluminum	max	0.0	0.0	0.0	0.0	0.8	0.0	0.6	0.0	0.1
	mean	0.0	0.0	0.0	0.0	0.6	0.0	0.4	0.0	0.1
Bismuth	max	nd	nd	0.0	0.0	nd	nd	nd	nd	nd
	mean	nd	nd	0.0	0.0	nd	nd	nd	nd	nd
Boron	max	0.0	0.0	0.0	0.0	0.0	0.0	0.0	0.0	0.0
	mean	0.0	0.0	0.0	0.0	0.0	0.0	0.0	0.0	0.0
Cadmium	max	0.0	0.0	0.0	0.0	0.0	0.0	0.0	0.0	0.0
	mean	0.0	0.0	0.0	0.0	0.0	0.0	0.0	0.0	0.0
Calcium	max	nd	nd	0.0	nd	N/A	N/A	N/A	N/A	N/A
	mean	nd	nd	0.0	nd	N/A	N/A	N/A	N/A	N/A
Chromium	max	0.0	0.0	0.0	0.0	0.0	0.0	0.0	0.0	0.0
	mean	0.0	0.0	0.0	0.0	0.0	0.0	0.0	0.0	0.0
Copper	max	0.1	0.1	0.0	0.1	0.0	0.0	0.0	0.0	0.0
	mean	0.0	0.0	0.0	0.1	0.0	0.0	0.0	0.0	0.0
Iron	max	0.0	0.0	0.0	0.0	nd	nd	nd	nd	nd
	mean	0.0	0.0	0.0	0.0	nd	nd	nd	nd	nd
Lead	max	0.0	0.0	0.0	0.0	0.0	0.0	0.0	0.0	0.0
	mean	0.0	0.0	0.0	0.0	0.0	0.0	0.0	0.0	0.0
Manganese	max	0.0	0.0	0.0	0.0	0.0	0.0	0.0	0.0	0.0
	mean	0.0	0.0	0.0	0.0	0.0	0.0	0.0	0.0	0.0
Nickel	max	0.0	0.0	0.0	0.0	0.0	0.0	0.0	0.0	0.0
	mean	0.0	0.0	0.0	0.0	0.0	0.0	0.0	0.0	0.0
Phosphorus	max	0.0	0.0	0.0	0.0	N/A	N/A	N/A	N/A	N/A
	mean	0.0	0.0	0.0	0.0	N/A	N/A	N/A	N/A	N/A
Sodium	max	0.0	0.0	0.0	0.0	N/A	N/A	N/A	N/A	N/A
	mean	0.0	0.0	0.0	0.0	N/A	N/A	N/A	N/A	N/A

COPC		Fish	Frog (Tadpole)	Benthic Invertebrate	Aquatic Plant	Muskrat	Trumpeter Swan	Bufflehead	Common Tern	Ring-Billed Gull
Thallium	max	0.0	0.0	0.0	0.0	3.7	nd	nd	nd	nd
	mean	0.0	0.0	0.0	0.0	2.9	nd	nd	nd	nd
Tin	max	nd	nd	0.0	nd	0.0	0.0	0.0	0.0	0.0
	mean	nd	nd	0.0	nd	0.0	0.0	0.0	0.0	0.0
Zinc	max	0.0	0.0	0.0	0.0	0.0	0.0	0.0	0.0	0.0
	mean	0.0	0.0	0.0	0.0	0.0	0.0	0.0	0.0	0.0

Note:

Ca, Na, and P are considered non-toxic to birds and mammals; therefore have been labelled as not applicable (N/A).

Bold and shaded values indicate a HQ > 1

nd = indicates no data are available.

E.5 References

- Alpine, A.E. (ed). 2010. Hydrological, Geological, and Biological Site Characterization of Breccia Pipe Uranium Deposit in Northern Arizona. U.S. Geological Survey Scientific Investigations Report 2010–5025, 353 p., 1 pl., scale 1:375,000. Bentley et al., 1978.
- Bentley, R.E., J.W. Dean, T.A. Hollister, G.A. LeBlanc, S. Sauter, B.H. Sleight III, and W.G. Wilson, 1978. Laboratory Evaluation of the Toxicity of Elemental Phosphorus (P₄) to Aquatic Organisms. U.S. Army Med. Res. Dev. Command, Washington, D.C.:105 p.
- Birge, W.J., J.A. Black, A.G. Westerman, and J.E. Hudson. 1980. Aquatic Toxicity Tests on Inorganic Elements Occurring in Oil Shale. In: C. Gale (Ed.), EPA-600/9-80-022, Oil Shale Symposium: Sampling, Analysis and Quality Assurance, March 1979, U.S. EPA, Cincinnati, OH:519-534.
- Borgmann, U., Y Couillard, P. Doyle, and D.G. Dixon. 2005. Toxicity of Sixty-three Metals and Metalloids to *Hyalella azteca* at two levels of Water Hardness. Environ. Tox. and Chem 24(3): 641-652.
- Bringmann, G., and R. Kuhn. 1959. Comparative Water-Toxicological Investigations on Bacteria, Algae, and *Daphnia*. Gesundheitsingenieur 80(4):115-120.
- British Columbia Ministry of Environment, (BC MOE). 2008. Ambient Aquatic Life Guidelines for Iron. Overview Report. Available at:
http://www.env.gov.bc.ca/wat/wq/BCguidelines/iron/iron_overview.pdf
- CCME. 2009. Canadian Water Quality Guidelines for the Protection of Aquatic Life. Boron. Available at: <http://cegg-rcqe.ccme.ca/download/en/324>
- Environment Canada and Health Canada (EC/HC). 2003. Priority Substances List Assessment Report: Releases of Radionuclides from Nuclear Facilities (Impact on Non-Human Biota).
- Fargasova, A., A. Bumbalova, and E. Havranek. 1999. Ecotoxicological Effects and Uptake of Metals (Cu⁺, Cu²⁺, Mn²⁺, Mo⁶⁺, Ni²⁺, V⁵⁺) in Freshwater Alga *Scenedesmus quadricauda*. Chemosphere 38(5):1165-1173.
- Golder Associates Ltd. and EcoMetrix Incorporated (Golder and EcoMetrix). 2017. Pickering Safe Storage Project Predictive Effects Assessment. Report No. P-REP-07701-00002, R0. April.
- Qiu, H., J. Geng, H. Ren, X. Xia, X. Wang, and Y. Yu, 2013. Physiological and Biochemical Responses of *Microcystis aeruginosa* to Glyphosate and Its Roundup Formulation. J. Hazard. Mater. 248/249(0): 172-176.

Sample, B.E., D.M. Opresko, and G.W. Suter II 1996. Toxicological Benchmarks for Wildlife: 1996 Revision. U.S. Department of Energy. June.

Suter G.W. II and C.L. Tsao 1996. Toxicological Benchmarks for Screening Potential Contaminants of Concern for Effects on Aquatic Biota. 1996 Revision. U.S. Department of Energy. June.

US EPA. 2006. Ecological Soil Screening Levels for Silver. Interim Final. OSWER Directive 9285.7-77.

US EPA. 1978. In-depth studies and health and environmental impacts of selected water pollutants.

Van Dam, R.A., A.C. Hogan, C.D. McCullough, M.A. Houston, C.L. Humphrey, and A.J. Harford. 2010. Aquatic Toxicity of Magnesium Sulfate, and the Influence of Calcium, in very Low Ionic Concentration Water. Environ. Toxicol. Chem. 29(2): 410-421.

Appendix F Summary of Data from Baseline Environmental Sampling Program

Table F.1: Lake Ontario Surface Water Data

Analyte	Unit	Detection Limit	LWC-1	LWC-1	LWC-1	LWC-1	LW-10	LW-10	LW-10	LW-21	LW-21	LW-21	LW-21	LW-9	LW-9	LW-9	LW-9	LW-9	LW-9	LWE-1	LWE-1	LWE-1	LWE-1	FB-1	FB-1	FB-1	FB-1	FB-1	FB-1	
			22/07/2015	22/07/2015	27/08/2015	27/08/2015	23/07/2015	23/07/2015	27/08/2015	23/07/2015	23/07/2015	27/08/2015	27/08/2015	27/08/2015	23/07/2015 ⁽²⁾	23/07/2015 ⁽³⁾	27/08/2015	27/08/2015	23/07/2015	23/07/2015	27/08/2015	27/08/2015	23/07/2015	23/07/2015	27/08/2015	23/07/2015 ⁽³⁾	23/07/2015	27/08/2015	27/08/2015	23/07/2015
General Chem																														
Alkalinity (Total as CaCO3)	mg/L	1	91	92	93	96	93	93	96	93	94	96	96	93	92	96	95	98	92	93	96	95	110	110	93	97	100	97		
Ammonia Nitrogen	mg/L	0.05	<0.05	<0.05	<0.05	<0.05	<0.05	<0.05	<0.05	<0.05	<0.05	<0.05	<0.05	<0.05	<0.05	<0.05	<0.05	<0.05	<0.05	<0.05	<0.05	<0.05	<0.05	<0.05	<0.05	<0.05	<0.05	<0.05	<0.05	
Un-ionized Ammonia, calculated	mg/L	0.0032	<0.0023	<0.0017	<0.0013	<0.0010	<0.0016	<0.0016	<0.0017	<0.0013	<0.0013	<0.0020	<0.0017	<0.0010	<0.0017	<0.0014	<0.0014	<0.00074	<0.0005	<0.0009	<0.00088	<0.00058	<0.0012	<0.0012	<0.00077	<0.0013	<0.0013	<0.00079	<0.0029	
Biochemical Oxygen Demand, 5 Day	mg/L	2	<2.0	<2.0	<2.0	<2.0	<2.0	<2.0	<2.0	<2.0	<2.0	<2.0	<2.0	<2.0	<2.0	<2.0	<2.0	<2.0	<2.0	<2.0	<2.0	<2.0	<2.0	<2.0	<2.0	<2.0	<2.0	<2.0	<2.0	
Chemical Oxygen Demand	mg/L	4	<4.0	9.6	<4.0	<4.0	<4.0	<4.0	<4.0	<4.0	5.8	4.6	<4.0	<4.0	4.0	6.2	<4.0	4.9	<4.0	<4.0	4.8	5	8.9	<4.0	<4.0	<4.0	<4.0	<4.0	8.6	
Conductivity	µS/cm	0.001	0.31	0.31	0.316	0.318	0.32	0.32	0.315	0.32	0.32	0.316	0.32	0.316	0.32	0.314	0.315	0.32	0.32	0.316	0.317	0.316	0.317	0.32	0.32	0.32	0.32	0.32	0.32	
Conductivity, field measured	µS/cm		0.226	0.204	0.302	0.302	0.291	0.291	0.305	0.289	0.289	0.307	0.287	0.286	0.304	0.304	0.303	0.286	0.289	0.305	0.303	0.303	0.289	0.303	0.289	0.322	0.322	0.322	0.303	
Hardness, Calcium Carbonate	mg/L	1	120	120	130	140	120	130	140	120	130	140	120	130	130	140	120	130	140	130	140	130	150	160	130	140	140	130	130	
Temperature, field measured	°C		14.15	10.03	12.2	12.94	18.45	18.45	18.38	16.84	16.84	23.11	21.11	12.41	7.83	15.5	15.5	7.89	11.95	7.28	12.2	8.84	12.04	12.04	7.6	7.59	13.63	13.63	9.53	
Total Suspended Solids	mg/L	1	<1.0	<1.0	<1.0	<1.0	<1	<1	<1.0	<1	<1	<1	<1	<1	<1	<1.0	<1	<1	<1	<1	<1	<1	<1	<1	<1	<1	<1	<1	<1	
pH	pH units		7.97	8.13	7.73	7.78	8.04	8.08	7.7	8.01	8.09	7.72	7.71	8.06	8.02	7.61	7.72	8.06	8.05	8	7.68	7.7	8.18	8.12	8.04	7.6	7.71	7.78	7.78	
pH, field measured	pH units		8.27	8.27	8.08	7.94	7.97	7.97	7.97	7.94	7.92	7.92	7.96	8.34	8	8	7.99	7.61	8.09	7.91	7.91	7.84	8.06	8.06	8.01	8.04	8.04	7.95	7.95	
Total Residual Chlorine, field measured	mg/L	0.0012	<0.0012	<0.0012	<0.0012	<0.0012	<0.0012	<0.0012	<0.0012	<0.0012	<0.0012	<0.0012	<0.0012	<0.0012	<0.0012	<0.0012	<0.0012	<0.0012	<0.0012	<0.0012	<0.0012	<0.0012	<0.0012	<0.0012	<0.0012	<0.0012	<0.0012	<0.0012	<0.0012	
Metals/Metalloids																														
Aluminum	mg/L	0.005	0.01	0.0053	0.008	<0.0050	0.0057	0.0096	0.0063	0.0072	0.0088	0.0075	0.0058	0.0063	0.0073	0.007	0.009	0.0053	0.0061	0.0063	0.007	0.0062	0.014	0.0079	0.033	0.013	0.013	<0.0050	<0.0050	
Aluminum, filtered	mg/L	0.005	0.021	<0.0050	<0.0050	<0.0050	<0.0050	<0.0050	<0.0050	<0.0050	<0.0050	<0.0050	<0.0050	<0.0050	<0.0050	<0.0050	<0.0050	<0.0050	<0.0050	<0.0050	<0.0050	<0.0050	<0.0050	<0.0050	<0.0050	<0.0050	<0.0050	<0.0050	<0.0050	<0.0050
Antimony	mg/L	0.0005	<0.0005	<0.0005	<0.0005	<0.0005	<0.0005	<0.0005	<0.0005	<0.0005	<0.0005	<0.0005	<0.0005	<0.0005	<0.0005	<0.0005	<0.0005	<0.0005	<0.0005	<0.0005	<0.0005	<0.0005	<0.0005	<0.0005	<0.0005	<0.0005	<0.0005	<0.0005	<0.0005	<0.0005
Arsenic	mg/L	0.001	<0.0010	<0.0010	<0.0010	<0.0010	<0.0010	<0.0010	<0.0010	<0.0010	<0.0010	<0.0010	<0.0010	<0.0010	<0.0010	<0.0010	<0.0010	<0.0010	<0.0010	<0.0010	<0.0010	<0.0010	<0.0010	<0.0010	<0.0010	<0.0010	<0.0010	<0.0010	<0.0010	<0.0010
Barium	mg/L	0.002	0.023	0.022	0.022	0.022	0.022	0.022	0.021	0.023	0.023	0.021	0.023	0.023	0.023	0.022	0.022	0.022	0.022	0.022	0.022	0.022	0.022	0.022	0.022	0.022	0.022	0.022	0.022	0.022
Beryllium	mg/L	0.0005	<0.0005	<0.0005	<0.0005	<0.0005	<0.0005	<0.0005	<0.0005	<0.0005	<0.0005	<0.0005	<0.0005	<0.0005	<0.0005	<0.0005	<0.0005	<0.0005	<0.0005	<0.0005	<0.0005	<0.0005	<0.0005	<0.0005	<0.0005	<0.0005	<0.0005	<0.0005	<0.0005	<0.0005
Bismuth	mg/L	0.001	<0.001	<0.001	<0.001	<0.001	<0.001	<0.001	<0.001	<0.001	<0.001	<0.001	<0.001	<0.001	<0.001	<0.001	<0.001	<0.001	<0.001	<0.001	<0.001	<0.001	<0.001	<0.001	<0.001	<0.001	<0.001	<0.001	<0.001	<0.001
Boron	mg/L	0.01	0.026	0.025	0.026	0.025	0.027	0.024	0.024	0.024	0.024	0.024	0.025	0.025	0.025	0.025	0.025	0.025	0.025	0.025	0.025	0.025	0.025	0.025	0.025	0.025	0.025	0.025	0.025	0.025
Cadmium	mg/L	0.0001	0.000014	0.000014	<0.000005	<0.000005	<0.000010	<0.000010	<0.000005	0.00001	<0.000010	<0.000005	0.000019	<0.000010	0.000013	<0.000005	<0.000005	<0.000005	0.000013	<0.000010	<0.000005	<0.000005	<0.000010	<0.000005	<0.000010	0.000005	<0.000005	<0.000005	<0.000005	<0.000005
Calcium	mg/L	0.2	35	34	34	33	35	34	35	34	35	33	35	34	35	34	35	34	35	34	35	35	37	34	35	37	34	35	35	35
Chromium	mg/L	0.005	<0.0050	<0.0050	<0.0050	<0.0050	<0.0050	<0.0050	<0.0050	<0.0050	<0.0050	<0.0050	<0.0050	<0.0050	<0.0050	<0.0050	<0.0050	<0.0050	<0.0050	<0.0050	<0.0050	<0.0050	<0.0050	<0.0050	<0.0050	<0.0050	<0.0050	<0.0050	<0.0050	<0.0050
Cobalt	mg/L	0.0005	<0.0005	<0.0005	<0.0005	<0.0005	<0.0005	<0.0005	<0.0005	<0.0005	<0.0005	<0.0005	<0.0005	<0.0005	<0.0005	<0.0005	<0.0005	<0.0005	<0.0005	<0.0005	<0.0005	<0.0005	<0.0005	<0.0005	<0.0005	<0.0005	<0.0005	<0.0005	<0.0005	<0.0005
Copper	mg/L	0.001	<0.0010	<0.0010	<0.0010	<0.0010	0.002	0.0013	0.0013	0.0013	0.0013	0.001	0.0017	<0.0010	0.0013	0.001	<0.0010	0.0017	0.0024	0.0088	0.0012	0.0011	<0.0010	<0.0010	0.0013	<0.0010	<0.0010	<0.0010	<0.0010	<0.0010
Lead	mg/L	0.1	<0.0005	<0.0005	<0.0005	<0.0005	<0.0005	<0.0005	<0.0005	<0.0005	<0.0005	<0.0005	<0.0005	<0.0005	<0.0005	<0.0005	<0.0005	<0.0005	<0.0005	<0.0005	<0.0005	<0.0005	<0.0005	<0.0005	<0.0005	<0.0005	<0.0005	<0.0005	<0.0005	<0.0005
Lithium	mg/L	0.0005	<0.005	<0.005	<0.005	<0.005	<0.005	<0.005	<0.005	<0.005	<0.005	<0.005	<0.005	<0.005	<0.005	<0.005	<0.005	<0.005	<0.005	<0.005	<0.005	<0.005	<0.005	<0.005	<0.005	<0.005	<0.005	<0.005	<0.005	<0.005
Magnesium	mg/L	0.005	8.9	8.5	9.1	8.6	8.7	8.6	8.9	8.9	8.7	8.9	8.7	8.9	8.2	9	8.6	8.2	9	8.6	8.5	8.7	8.6	8.4	8.8	8.8	8.8	8.8	8.8	
Manganese	mg/L	0.05	<0.0020	<0.0020	<0.0020	<0.0020	<0.0020	<0.0020	<0.0020	<0.0020	<0.0020	<0.0020	<0.0020	<0.0020	<0.0020	<0.0020	<0.0020	<0.0020	<0.0020	<0.0020	<0.0020	<0.0020	0.0035	0.003	<0.0020	0.017	0.0057	<0.0020	<0.0020	
Mercury	mg/L	0.0001	<0.0001	<0.0001	0.00001	0.00001	<0.0001	<0.0001	<0.0001	<0.0001	<0.0001	0.00001	<0.0001	<0.0001	<0.0001	<0.0001	<0.0001	<0.0001	<0.0001	<0.0001	<0.0001	<0.0001	<0.0001	<0.0001	<0.0001	<0.0001	<0.0001	<0.0001	<0.0001	<0.0001
Molybdenum	mg/L	0.002	0.0014	0.0014	0.0012	0.0012	0.0014	0.0012	0.0012	0.0013	0.0014	0.0011	0.0013	0.0013	0.0013	0.0012	0.0012	0.0012	0.0012	0.0014	0.0013	0.0011	0.0011	0.0012	0.0012	0.0013	0.0013	0.0013	0.0013	0.0012
Nickel	mg/L	0.0005	<0.0010	<0.0010	0.0011	<0.0010	0.001	<0.0010	0.0012	0.0012	<0.0010	<0.0010	<0.0010	<0.0010	<0.0010	<0.0010	<0.0010	0.0015	<0.0010	0.0014	<0.0010	<0.0010	<0.0010	<0.0010	<0.0010	<0.0010	<0.0010	<0.0010	<0.0010	<0.0010
Potassium	mg/L	0.001	1.6	1.6	1.7	1.6	1.6	1.6	1.6	1.6	1.7	1.6	1.6	1.6	1.6	1.6	1.6	1.6	1.6	1.6	1.6	1.6	1.6	1.6	1.6	1.6	1.6	1.6	1.6	1.6
Selenium	mg/L	0.2	0.0017	0.0013	0.00129	0.00126	0.002	0.0016	0.0012	0.0011	0.00115	0.00149	0.00021	0.0002	0.00123	0.00131	0.00128	0.0013	0.00128	0.0013	0.002	0.00142	0.00117	0.0012	0.0018	0.0016</				

Table F.2: Frenchman's Bay Surface Water Data

Analyte	Sample Depth	Unit	Detection Limit	LWC-1	LWC-1	LWC-1	LWC-1	LOCATION 1	LOCATION 1	LOCATION 2	LOCATION 3	PN-5-1	PN-9-1	PN-10-1	PN-10-1		
				22/07/2015	22/07/2015	27/08/2015	27/08/2015	23/07/2015	23/07/2015	23/07/2015	23/07/2015	23/07/2015	23/07/2015	23/07/2015	23/07/2015	23/07/2015	23/07/2015
				LWC-1-0.3	LWC-1-5	LWC-1-0.3	LWC-1-5	LOC-1	DUP-5 (Field Duplicate)	LOC-2	LOC-3	PN-5-1	PN-9-1	PN-10-1	DUP-4 (Field Duplicate)		
General Chem																	
Alkalinity (Total as CaCO3)	mg/L	1	91	92	93	96	150	150	120	120	120	120	120	120	120		
Ammonia Nitrogen	mg/L	0.05	<0.05	<0.05	<0.05	<0.05	<0.05	<0.05	<0.05	<0.05	<0.05	<0.05	<0.05	<0.05	<0.05		
Unionized Ammonia, calculated	mg/L	0.0032	<0.0023	<0.0017	<0.0013	<0.0010	<0.0032	<0.0032	<0.0033	<0.0056	<0.0069	<0.0061	<0.0066	<0.0056	<0.0056		
Biochemical Oxygen Demand, 5 Day	mg/L	2	3.0	2.0	<2.0	<2.0	4	3	5	3	3	3	3	<2.0	<2.0		
Chemical Oxygen Demand	mg/L	4	<4.0	9.6	<4.0	<4.0	15	9.6	12	12	10	11	11	11	7.4		
Conductivity	ms/cm	0.001	0.31	0.31	0.316	0.316	0.86	0.86	0.57	0.57	0.54	0.55	0.55	0.58	0.58		
Conductivity, field measured	ms/cm		0.226	0.204	0.202	0.202	0.774	0.774	0.496	0.532	0.495	0.518	0.518	0.515	0.515		
Hardness, Calcium Carbonate	mg/L	1	120	120	130	140	200	210	170	160	150	150	160	160	150		
Temperature, field measured	C		14.15	10.03	12.2	12.94	23.94	23.94	23.53	23.35	21.52	21.61	21.1	21.1	21.1		
Total Suspended Solids	mg/L	1	<1.0	<1.0	<10.0	<10.0	20	20	11	17	10	10	9	5	5		
Total Organic Carbon	mg/L	0.2	--	--	--	--	4.9	4.9	4.6	4.8	4.5	4.5	4.4	3	3		
pH, field measured	pH units		7.97	8.13	7.73	7.78	8.08	8.12	8.18	8.06	8.23	8.26	8.21	8.22	8.22		
pH, field measured	pH units		8.27	8.27	8.08	7.94	8.11	8.11	8.14	8.4	8.56	8.49	8.47	8.47	8.47		
Total Residual Chlorine, field measured	mg/L	0.0012	<0.0012	<0.0012	<0.0012	<0.0012	<0.0012	<0.0012	<0.0012	<0.0012	<0.0012	<0.0012	<0.0012	<0.0012	<0.0012		
Metals/Metalloids																	
Aluminum	mg/L	0.005	0.01	0.0053	0.008	<0.0050	0.22	0.27	0.13	0.17	0.09	0.093	0.1	0.05	0.05		
Aluminum, filtered	mg/L	0.005	0.001	<0.0050	<0.0050	<0.0050	0.006	0.006	0.006	0.005	<0.0050	<0.0050	<0.0050	<0.0050	<0.0050		
Antimony	mg/L	0.0005	<0.0005	<0.0005	<0.0005	<0.0005	<0.0005	<0.0005	<0.0005	<0.0005	<0.0005	<0.0005	<0.0005	<0.0005	<0.0005		
Arsenic	mg/L	0.001	<0.0010	<0.0010	<0.0010	<0.0010	0.001	<0.0010	<0.0010	0.0011	0.001	0.001	0.0011	<0.0010	<0.0010		
Barium	mg/L	0.002	0.023	0.022	0.022	0.022	0.046	0.044	0.034	0.035	0.032	0.03	0.032	0.024	0.024		
Beryllium	mg/L	0.0005	<0.0005	<0.0005	<0.0005	<0.0005	<0.0005	<0.0005	<0.0005	<0.0005	<0.0005	<0.0005	<0.0005	<0.0005	<0.0005		
Bismuth	mg/L	0.001	<0.001	<0.001	<0.001	<0.001	<0.001	<0.001	<0.001	<0.001	<0.001	<0.001	<0.001	<0.001	<0.001		
Boron	mg/L	0.01	0.026	0.025	0.025	0.025	0.042	0.04	0.035	0.034	0.033	0.033	0.034	0.027	0.027		
Cadmium	mg/L	0.0001	0.00014	0.000014	<0.000005	<0.000005	<0.000010	0.00001	<0.000010	<0.000010	<0.000010	<0.000010	<0.000010	0.00001	0.00001		
Calcium	mg/L	0.2	35	34	34	33	64	63	49	48	46	47	47	36	36		
Chromium	mg/L	0.005	<0.0050	<0.0050	<0.0050	<0.0050	<0.0050	<0.0050	<0.0050	<0.0050	<0.0050	<0.0050	<0.0050	<0.0050	<0.0050		
Cobalt	mg/L	0.0005	<0.0005	<0.0005	<0.0005	<0.0005	<0.0005	<0.0005	<0.0005	<0.0005	<0.0005	<0.0005	<0.0005	<0.0005	<0.0005		
Copper	mg/L	0.001	<0.0010	<0.0010	<0.0010	<0.0010	0.0017	0.0015	0.0014	0.0014	0.0018	0.0021	0.0021	0.0019	0.0019		
Lead	mg/L	0.1	<0.0005	<0.0005	<0.0005	<0.0005	0.00081	0.00092	0.00062	0.00062	<0.0005	<0.0005	<0.0005	<0.0005	<0.0005		
Lithium	mg/L	0.0005	<0.005	<0.005	<0.005	<0.005	<0.005	<0.005	<0.005	<0.005	<0.005	<0.005	<0.005	<0.005	<0.005		
Magnesium	mg/L	0.005	8.9	8.5	9.1	8.6	11	11	9.4	9.3	9.1	9.2	9.4	8.6	8.6		
Manganese	mg/L	0.05	<0.0020	<0.0020	<0.0020	<0.0020	0.078	0.08	0.045	0.058	0.03	0.031	0.031	0.011	0.011		
Mercury	mg/L	0.0001	<0.0001	<0.0001	0.00001	0.00001	<0.0001	<0.0001	<0.0001	<0.0001	<0.0001	<0.0001	<0.0001	<0.0001	<0.0001		
Molybdenum	mg/L	0.002	0.0014	0.0014	0.0012	0.0012	0.001	0.0012	0.0011	0.0012	0.0011	0.0012	0.0012	0.0012	0.0013		
Nickel	mg/L	0.0005	<0.0010	<0.0010	0.0011	<0.0010	0.001	0.0013	<0.0010	<0.0010	<0.0010	<0.0010	<0.0010	<0.0010	<0.0010		
Potassium	mg/L	0.001	1.6	1.6	1.7	1.6	2.3	2.3	2	2.1	2	2	2	1.6	1.6		
Selenium	mg/L	0.2	0.00017	0.00013	0.000129	0.000126	0.00011	0.00013	0.00014	0.00012	<0.0001	0.00013	0.00013	0.00022	0.00013		
Silicon	mg/L	0.05	0.19	0.27	0.27	0.31	1.4	1.4	0.84	0.91	0.6	0.6	0.61	0.45	0.45		
Silver	mg/L	0.002	<0.0001	<0.0001	<0.0001	<0.0001	<0.0001	<0.0001	<0.0001	<0.0001	<0.0001	<0.0001	<0.0001	<0.0001	<0.0001		
Sodium	mg/L	0.0001	14	14	16	14	91	89	54	53	48	48	48	24	24		
Strontium	mg/L	0.1	0.18	0.18	0.18	0.18	0.28	0.28	0.23	0.23	0.22	0.22	0.22	0.19	0.19		
Tellurium	mg/L	0.001	<0.0010	<0.0010	<0.0010	<0.0010	<0.0010	<0.0010	<0.0010	<0.0010	<0.0010	<0.0010	<0.0010	<0.0010	<0.0010		
Thallium	mg/L	0.001	<0.000050	<0.000050	<0.000050	<0.000050	<0.000050	<0.000050	<0.000050	<0.000050	<0.000050	<0.000050	<0.000050	<0.000050	<0.000050		
Tin	mg/L	0.00005	<0.0010	<0.0010	<0.0010	<0.0010	<0.0010	<0.0010	<0.0010	<0.0010	<0.0010	<0.0010	<0.0010	<0.0010	<0.0010		
Titanium	mg/L	0.001	<0.005	<0.005	<0.005	<0.005	0.011	0.013	0.0059	0.0082	0.006	0.0055	0.0056	<0.0050	<0.0050		
Tungsten	mg/L	0.005	<0.0010	<0.0010	<0.0010	<0.0010	<0.0010	<0.0010	<0.0010	<0.0010	<0.0010	<0.0010	<0.0010	<0.0010	<0.0010		
Uranium	mg/L	0.001	0.00042	0.00037	0.00035	0.00033	0.00045	0.00045	0.00038	0.00037	0.00038	0.00037	0.00038	0.00039	0.00039		
Vanadium	mg/L	0.0001	<0.0005	<0.0005	<0.0005	<0.0005	0.0013	0.0013	0.001	0.0012	0.00084	0.0009	0.0008	0.00055	0.00055		
Zinc	mg/L	0.0005	<0.0050	<0.0050	<0.0050	<0.0050	0.0051	<0.0050	<0.0050	0.0074	<0.0050	<0.0050	<0.0050	<0.0050	<0.0050		
Zirconium	mg/L	0.005	<0.0010	<0.0010	<0.0010	<0.0010	<0.0010	<0.0010	<0.0010	<0.0010	<0.0010	<0.0010	<0.0010	<0.0010	<0.0010		
Iron	mg/L	0.001	<0.1	<0.1	<0.1	<0.1	0.49	0.56	0.26	0.35	0.18	0.19	0.19	<0.1	<0.1		
PetrHydroCarb																	
Petroleum Hydrocarbons - F1 (C6-C10),BTEX	mg/L	0.025	<0.025	<0.025	<0.025	<0.025	<0.025	<0.025	<0.025	<0.025	<0.025	<0.025	<0.025	<0.025	<0.025		
Petroleum Hydrocarbons - F1 (C6-C10)	mg/L	0.025	<0.025	<0.025	<0.025	<0.025	<0.025	<0.025	<0.025	<0.025	<0.025	<0.025	<0.025	<0.025	<0.025		
Petroleum Hydrocarbons - F2 (C10-C16)	mg/L	0.1	<0.1	<0.1	<0.1	<0.1	<0.1	<0.1	<0.1	<0.1	<0.1	<0.1	<0.1	<0.1	<0.1		
Petroleum Hydrocarbons - F3 (C16-C34)	mg/L	0.2	<0.2	<0.2	<0.2	<0.2	<0.2	<0.2	<0.2	<0.2	<0.2	<0.2	<0.2	<0.2	<0.2		
Petroleum Hydrocarbons - F4 (C34-C50)	mg/L	0.2	<0.2	<0.2	<0.2	<0.2	<0.2	<0.2	<0.2	<0.2	<0.2	<0.2	<0.2	<0.2	<0.2		
Other																	
Morpholine	mg/L	0.004	<0.004	<0.004	<0.004	<0.004	<0.004	<0.004	<0.004	<0.004	<0.004	<0.004	<0.004	<0.004	<0.004		
Radionuclides																	
Tritium	Bq/L	4.4	<4.5	<4.5	<4.2	<4.2	14.6	13.1	11.1	16.2	11.6	14.8	12.3	13.5	13.5		
Carbon-14	Bq/L	0.1	<0.1	<0.1	<0.1	<0.1	<0.1	<0.1	<0.1	<0.1	<0.1	<0.1	<0.1	<0.1	<0.1		
Cobal-60	Bq/L	0.1	<0.1	<0.1	<0.1	<0.1	<0.1	<0.1	<0.1	<0.1	<0.1	<0.1	<0.1	<0.1	<0.1		
Cesium-134	Bq/L	0.1	<0.1	<0.1	<0.1	<0.1	<0.1	<0.1	<0.1	<0.1	<0.1	<0.1	<0.1	<0.1	<0.1		
Cesium-137	Bq/L	0.1	<0.1	<0.1	<0.1	<0.1	<0.1	<0.1	<0.1	<0.1	<0.1	<0.1	<0.1	<0.1	<0.1		

Table F.3: Frenchman's Bay Sediment Data

Analyte	Unit	Detection Limit	LOCATION 1	LOCATION 2	LOCATION 3	F-4	FB-5	FB-6	FB-7	FB-8	FB-9	FB-9	FB-10	PN-1-1	PN-2-1	PN-2-1	PN-3-1	PN-4-1	PN-5-1	PN-6-1	PN-7-1	PN-8-1	PN-9-1	PN-10-1		
			2015/07/24	2015/07/24	2015/07/24	2015/07/24	2015/07/24	2015/07/24	2015/07/24	2015/07/24	2015/07/24	2015/07/24	2015/07/24	2015/07/24	2015/07/24	2015/07/24	2015/07/24	2015/07/24	2015/07/24	2015/07/24	2015/07/24	2015/07/24	2015/07/24	2015/07/24	2015/07/24	2015/07/24
			LOC-1	LOC-2	LOC-3	F-4	FB-5	FB-6	FB-7	FB-8	FB-9	DUP-2 (Field Duplicate)	FB-10	PN-1-1	PN-2-1	DUP-1 (Field Duplicate)	PN-3-1	PN-4-1	PN-5-1	PN-6-1	PN-7-1	PN-8-1	PN-9-1	PN-10-1		
Sample Depth	cm		0-5	0-5	0-5	0-5	0-5	0-5	0-5	0-5	0-5	0-5	0-5	0-5	0-5	0-5	0-5	0-5	0-5	0-5	0-5	0-5	0-5	0-5	0-5	
General Chem																										
Total Organic Carbon	µg/g dw	500	12000	12000	81000	23000	68000	53000	64000	100000	71000	75000	34000	21000	56000	61000	38000	54000	49000	51000	29000	20000	54000	74000		
Gravel	%		0.24	0.32	0.45	<0.10	0.45	<0.10	0.14	0.44	0.38	<0.10	<0.10	<0.10	0.31	<0.10	<0.10	<0.10	<0.10	0.11	0.4	<0.10	0.3			
Sand	%		67	62	34	29	17	20	24	8.3	15	29	59	17	19	24	13	9.8	24	45	58	23	28			
Silt	%		29	33	49	64	64	58	54	51	55	68	63	51	52	48	54	51	57	40	32	53	48			
Clay	%		3.9	4.5	16	7.4	19	22	25	25	36	18	8.8	8.4	31	29	28	33	39	19	15	8.8	24			
Moisture	%		24.9	40.7	72	43.9	68.5	73.6	43.5	80.9	74.4	73.7	54.4	52	72.3	75.7	66.7	76.1	75.6	71.2	59.3	51.3	71.4	74.9		
Metals/Metalloids																										
Aluminum	µg/g dw	50	3700	3800	8200	6700	11000	11000	11000	8000	13000	12000	7200	5400	11000	11000	8700	12000	12000	7400	6800	5700	9900	9500		
Antimony	µg/g dw	0.2	<0.20	0.24	0.66	0.43	1.00	0.57	0.74	0.58	0.73	0.75	0.58	<0.20	0.55	0.65	0.42	0.55	0.57	0.36	0.32	0.28	0.58	0.56		
Arsenic	µg/g dw	1	1	1	3	2	4	4	3	3	3	2	3	5	5	4	5	4	3	3	3	4	5			
Barium	µg/g dw	0.5	29	28	66	47	86	92	98	69	100	93	57	38	95	92	71	110	98	62	53	43	81	82		
Beryllium	µg/g dw	0.2	<0.20	<0.20	0.43	0.35	0.54	0.51	0.54	0.40	0.58	0.56	0.37	0.27	0.52	0.51	0.43	0.55	0.55	0.40	0.35	0.27	0.47	0.51		
Bismuth	µg/g dw	1	<1.0	<1.0	<1.0	<1.0	<1.0	<1.0	<1.0	<1.0	<1.0	<1.0	<1.0	<1.0	<1.0	<1.0	<1.0	<1.0	<1.0	<1.0	<1.0	<1.0	<1.0	<1.0		
Boron	µg/g dw	5	<5.0	<5.0	8	5	9	7	9	9	8	8	6	<5.0	9	9	7	9	8	6	7	6	10	25		
Cadmium	µg/g dw	0.1	<0.10	0.10	0.34	0.31	0.61	0.57	0.60	0.39	0.54	0.47	0.40	0.31	0.71	0.72	0.49	0.66	0.62	0.51	0.49	0.34	0.63	0.75		
Calcium	µg/g dw	50	45000	48000	61000	74000	81000	100000	120000	70000	98000	91000	76000	89000	120000	110000	98000	130000	120000	96000	94000	98000	90000	87000		
Chromium	µg/g dw	1	10	10	19	19	29	26	27	19	28	26	23	13	27	28	23	31	28	20	18	14	26	26		
Cobalt	µg/g dw	0.1	3	3	6	6	8	8	8	5	8	7	6	5	8	8	7	8	8	6	6	5	7	7		
Copper	µg/g dw	0.5	11	10	41	29	52	44	47	50	54	49	37	26	63	63	45	65	60	44	41	29	63	74		
Iron	µg/g dw	50	7700	8100	14000	13000	19000	19000	20000	15000	21000	20000	14000	11000	20000	20000	16000	21000	20000	15000	14000	12000	17000	18000		
Lead	µg/g dw	1	9	8	28	20	41	36	38	27	37	34	26	16	40	41	28	42	37	27	22	17	38	43		
Magnesium	µg/g dw	50	3600	3800	5600	6900	8000	7300	7700	6100	8200	7900	6900	6800	8800	8700	8400	9600	8300	8700	8300	7200	8300	8500		
Manganese	µg/g dw	1	160	170	400	310	480	510	540	410	570	540	370	300	590	590	480	660	560	390	380	320	480	440		
Mercury	µg/g dw	0.05	<0.05	<0.05	<0.05	<0.05	0.06	0.05	0.06	<0.05	0.05	0.06	<0.05	<0.05	0.08	0.08	0.08	0.08	0.07	0.05	0.05	<0.05	0.07	0.07		
Molybdenum	µg/g dw	0.5	<0.50	<0.50	<0.50	<0.50	0.68	<0.50	0.55	0.51	0.60	0.52	<0.50	<0.50	0.51	0.55	<0.50	0.61	0.61	0.53	<0.50	<0.50	0.67	0.89		
Nickel	µg/g dw	0.5	6	6	14	13	20	18	19	14	21	19	14	12	21	22	17	23	21	16	15	12	19	20		
Phosphorus	µg/g dw	50	730	790	990	860	1000	1000	1000	920	1200	1100	890	740	1000	1100	910	1100	1000	920	960	840	1100	1500		
Potassium	µg/g dw	200	510	460	1100	900	1500	1400	1500	1100	1500	1500	990	890	1700	1700	1400	1900	1900	1100	1100	910	1400	1300		
Selenium	µg/g dw	0.5	<0.50	<0.50	0.78	<0.50	0.80	0.83	0.94	0.76	0.91	0.80	<0.50	<0.50	1.00	1.10	0.73	0.98	1.00	0.56	0.64	<0.50	0.90	1.10		
Silver	µg/g dw	0.2	<0.20	<0.20	<0.20	<0.20	<0.20	<0.20	<0.20	<0.20	<0.20	<0.20	<0.20	<0.20	0.21	0.21	<0.20	0.22	0.23	<0.20	<0.20	<0.20	0.20	0.25		
Sodium	µg/g dw	50	150	180	450	250	530	450	490	590	590	530	310	210	390	480	330	450	370	310	230	210	410	450		
Strontium	µg/g dw	1	74	78	110	120	150	170	200	130	170	150	120	150	200	190	170	220	190	160	160	160	160	160		
Thallium	µg/g dw	0.05	0.06	0.06	0.17	0.15	0.23	0.22	0.25	0.14	0.20	0.23	0.16	0.16	0.26	0.23	0.21	0.24	0.21	0.19	0.19	0.19	0.23	0.26		
Tin	µg/g dw	5	<5.0	<5.0	<5.0	<5.0	<5.0	<5.0	<5.0	<5.0	<5.0	<5.0	<5.0	<5.0	<5.0	<5.0	<5.0	<5.0	<5.0	<5.0	<5.0	<5.0	<5.0	<5.0		
Uranium	µg/g dw	0.05	0.29	0.33	0.51	0.39	0.50	0.49	0.50	0.58	0.52	0.50	0.41	0.42	0.59	0.52	0.49	0.55	0.55	0.49	0.52	0.43	0.51	0.68		
Vanadium	µg/g dw	5	12	13	21	19	27	26	28	20	26	26	20	16	27	28	23	28	29	21	19	17	23	25		
Zinc	µg/g dw	5	58	57	160	130	230	190	190	170	230	220	180	83	220	200	140	230	180	120	130	92	190	220		
Radionuclides																										
Carbon-14	Bq/kg-C dw	100	124	177	176	156	194	195	272	224	231	201	194	155	231	193	160	208	138	111	100	104	226	220		
Cobal-60	Bq/kg dw	1	<1	<1	<1	<1	<1	<1	<1	<1	<1	<1	<1	<1	<1	<1	<1	<1	<1	<1	<1	<1	<1	<1		
Cesium-134	Bq/kg dw	3.3	<3.3	<3.3	<3.3	<3.3	<3.3	<3.3	<3.3	<3.3	<3.3	<3.3	<3.3	<3.3	<3.3	<3.3	<3.3	<3.3	<3.3	<3.3	<3.3	<3.3	<3.3	<3.3		
Cesium-137	Bq/kg dw	1	<1	<1	<1	1.4	1.71	1.58	2.05	1.2	1.65	1.58	1.38	2.68	2.86	2.84	2.96	2.43	2.91	1.86	2.42	3.12	3.16	2.8		

Table F.4: Stormwater Data - PN U1-4 Outfall

Station ID Sample Date Unit	Catchment 2 MH137				Catchment 1 MH149				
	20-Aug-15	28-Oct-15	19-Nov-15	11-Jun-16	20-Aug-15	28-Oct-15	19-Nov-15	11-Jun-16	
	General								
Chloride	mg/L	25	25	27	24	650	110	790	150
Conductivity	ms/cm	0.31	0.301	0.323	0.29	2.32	0.521	2.99	0.714
Hardness, Calcium Carbonate	mg/L	120	120	130	120	260	93	430	98
pH	pH units	7.97	8.03	8.12	8.01	7.72	7.81	8.11	7.66
Phosphorous	mg/L	0.026	0.059	0.025	0.023	0.069	0.044	0.029	0.11
Total Suspended Solids	mg/L	< 10	46	< 10	<10	57	17	< 10	70
Toxicity									
% Mortality of Daphnia Magna in 100% Effluent Treatment	%	0	0	0	0	0	0	0	0
% Mortality of Rainbow Trout in 100% Effluent Treatment	%	0	0	0	0	0	0	0	0
Metals									
Aluminum	ug/L	67	300	110	19	680	350	57	1400
Antimony	ug/L	< 0.50	< 0.50	< 0.50	<0.50	1	< 0.50	0.59	0.56
Arsenic	ug/L	< 1.0	< 1.0	< 1.0	<1.0	< 1.0	< 1.0	< 1.0	<1.0
Barium	ug/L	26	28	26	22	64	19	67	31
Beryllium	ug/L	< 0.50	< 0.50	< 0.50	<0.50	< 0.50	< 0.50	< 0.50	<0.50
Bismuth	ug/L	< 1.0	< 1.0	< 1.0	<1.0	< 1.0	< 1.0	< 1.0	1.2
Boron	ug/L	26	19	24	15	32	11	19	<10
Cadmium	ug/L	< 0.10	< 0.10	< 0.10	<0.10	< 0.10	< 0.10	< 0.10	<0.10
Calcium	ug/L	35000	38000	38000	32000	96000	29000	140000	48000
Chromium	ug/L	< 5.0	< 5.0	< 5.0	<5.0	< 5.0	< 5.0	< 5.0	<5.0
Cobalt	ug/L	< 0.50	< 0.50	< 0.50	<0.50	0.65	< 0.50	< 0.50	1
Copper	ug/L	3.7	5.7	3.7	1.9	7.3	6.5	3.7	8.6
Iron	ug/L	110	570	200	<100	1200	450	190	1800
Lead	ug/L	< 0.50	1.1	< 0.50	<0.50	2.7	1.5	< 0.50	5.2
Lithium	ug/L	< 5.0	< 5.0	< 5.0	<5.0	< 5.0	< 5.0	< 5.0	<5.0
Magnesium	ug/L	8900	8400	8700	8100	13000	3500	20000	5200
Manganese	ug/L	13	37	9.3	2.8	110	59	16	120
Mercury (filtered)	ug/L	< 0.01	< 0.01	< 0.01	<0.01	< 0.01	< 0.01	< 0.01	<0.01
Molybdenum	ug/L	1.2	0.96	1.2	1.1	1.3	< 0.50	1.2	0.64
Nickel	ug/L	< 1.0	1.3	< 1.0	<1.0	2.5	< 1.0	< 1.0	2.6
Potassium	ug/L	1700	1600	1700	1600	2200	1100	2400	1900
Selenium	ug/L	< 2.0	< 2.0	< 2.0	<2.0	< 2.0	< 2.0	< 2.0	<2.0
Silicon	ug/L	240	810	530	370	2900	1300	2800	3400
Silver	ug/L	< 0.10	< 0.10	< 0.10	<0.10	< 0.10	< 0.10	< 0.10	<0.10
Sodium	ug/L	15000	14000	16000	14000	380000	63000	430000	99000
Strontium	ug/L	180	170	190	170	680	190	890	300
Tellurium	ug/L	< 1.0	< 1.0	< 1.0	<1.0	< 1.0	< 1.0	< 1.0	<1.0
Thallium	ug/L	< 0.050	< 0.050	< 0.050	<0.050	< 0.050	< 0.050	< 0.050	0.053
Tin	ug/L	< 1.0	< 1.0	< 1.0	<1.0	< 1.0	< 1.0	< 1.0	<1.0
Titanium	ug/L	< 5.0	16	7.1	<5.0	30	11	< 5.0	49
Tungsten	ug/L	< 1.0	< 1.0	< 1.0	<1.0	< 1.0	< 1.0	< 1.0	<1.0
Uranium	ug/L	0.89	0.46	0.62	0.45	0.3	0.33	0.58	0.37
Vanadium	ug/L	0.53	1.1	< 0.50	<0.50	2.9	1.2	< 0.50	3.6
Zinc	ug/L	< 5.0	20	12	<5.0	83	43	39	84
Zirconium	ug/L	< 1.0	< 1.0	< 1.0	<1.0	< 1.0	< 1.0	< 1.0	1.1
Petroleum Hydrocarbons (and BTEX)									
Benzene	ug/L	< 0.20	< 0.20	< 0.20	<0.20	< 0.20	< 0.20	< 0.20	<0.20
Toluene	ug/L	0.22	< 0.20	< 0.20	<0.20	< 0.20	< 0.20	< 0.20	<0.20
Ethylbenzene	ug/L	< 0.20	< 0.20	< 0.20	<0.20	< 0.20	< 0.20	< 0.20	<0.20
p-Xylene	ug/L	< 0.20	< 0.20	< 0.20	<0.20	< 0.20	< 0.20	< 0.20	<0.20
m,p-Xylenes	ug/L	< 0.40	< 0.40	< 0.40	<0.40	< 0.40	< 0.40	< 0.40	<0.40
Xylenes, Total	ug/L	< 0.40	< 0.40	< 0.40	<0.40	< 0.40	< 0.40	< 0.40	<0.40
Petroleum Hydrocarbons - F1 (C6-C10)-BTEX	ug/L	< 25	< 25	< 25	<25	< 25	< 25	< 25	<25
Petroleum Hydrocarbons - F1 (C6-C10)	ug/L	< 25	< 25	< 25	<25	< 25	< 25	< 25	<25
Petroleum Hydrocarbons - F2 (C10-C16)	ug/L	< 100	< 100	< 100	<100	< 100	< 100	< 100	<100
Petroleum Hydrocarbons - F3 (C16-C34)	ug/L	< 200	< 200	< 200	<200	< 200	< 200	< 200	<200
Petroleum Hydrocarbons - F4 (C34-C50)	ug/L	< 200	< 200	< 200	<200	< 200	< 200	< 200	<200
Reached Baseline at C50	ug/L	YES	YES	YES	YES	YES	YES	YES	YES
Radiological									
Carbon-14	Bq/L	< 20	< 20	< 20	<20	< 20	< 20	< 20	<20
Cesium-134	Bq/L	< 1	< 1	< 1	<1	< 1	< 1	< 1	<1
Cesium-137	Bq/L	< 1	< 1	< 1	<1	< 1	< 1	< 1	<1
Cobalt-60	Bq/L	-	< 1	< 1	<1	-	< 1	< 1	<1
Tritium (HTO)	Bq/L	21	588	145	163	327	141	882	235

Table F.5: Stormwater Data - PN U5-8 Outfall

Station ID Sample Date	Unit	Catchment 8 M3-3					Catchment 6 MH15			
		20-Aug-15	19-Nov-15	28-Oct-15	11-Jun-16		20-Aug-15	28-Oct-15	19-Nov-15	11-Jun-16
		Dup of M3-3								
General										
Chloride	mg/L	650	340	120	200	200	47	40	38	14
Conductivity	mS/cm	2.36	1.4	0.541	0.922	0.944	0.276	0.35	0.305	0.12
Hardness, Calcium Carbonate	mg/L	160	120	69	90	90	49	99	86	30
pH	pH units	7.91	7.83	7.77	7.91	7.87	7.47	7.85	7.84	7.8
Phosphorous	mg/L	0.029	0.025	0.037	0.05	0.052	0.54	0.16	0.27	0.13
Total Suspended Solids	mg/L	< 10	< 10	13	47	34	19	16	66	15
Toxicity										
% Mortality of Daphnia Magna in 100% Effluent Treatment	%	0	0	0	0	-	0	0	0	0
% Mortality of Rainbow Trout in 100% Effluent Treatment	%	0	0	0	0	-	0	0	0	0
Metals										
Aluminum	ug/L	110	79	460	390	370	270	210	1300	440
Antimony	ug/L	0.56	0.52	0.51	0.95	0.91	0.64	0.84	< 0.50	0.93
Arsenic	ug/L	< 1.0	< 1.0	< 1.0	1.4	1.5	< 1.0	< 1.0	< 1.0	< 1.0
Barium	ug/L	37	21	12	20	20	14	24	25	8.5
Beryllium	ug/L	< 0.50	< 0.50	< 0.50	< 0.50	< 0.50	< 0.50	< 0.50	< 0.50	< 0.50
Bismuth	ug/L	< 1.0	< 1.0	< 1.0	< 1.0	< 1.0	< 1.0	< 1.0	< 1.0	< 1.0
Boron	ug/L	45	14	< 10	13	12	16	17	12	< 10
Cadmium	ug/L	< 0.10	< 0.10	< 0.10	0.2	0.23	< 0.10	< 0.10	< 0.10	< 0.10
Calcium	ug/L	52000	39000	21000	39000	38000	19000	27000	36000	14000
Chromium	ug/L	< 5.0	< 5.0	< 5.0	5.1	< 5.0	< 5.0	< 5.0	< 5.0	< 5.0
Cobalt	ug/L	< 0.50	< 0.50	< 0.50	0.97	0.95	< 0.50	< 0.50	0.88	< 0.50
Copper	ug/L	6.2	3.6	5	12	11	11	7.1	7.4	7.5
Iron	ug/L	370	130	550	710	660	340	280	1600	510
Lead	ug/L	0.66	0.54	1.8	3.1	2.9	1.3	0.89	2.2	1.6
Lithium	ug/L	< 5.0	< 5.0	< 5.0	< 5.0	< 5.0	< 5.0	< 5.0	< 5.0	< 5.0
Magnesium	ug/L	6800	5300	2000	3300	3200	2200	4800	4700	1000
Manganese	ug/L	96	20	33	60	60	27	20	63	24
Mercury (filtered)	ug/L	< 0.01	< 0.01	< 0.01	< 0.01	0.01	< 0.01	< 0.01	0.02	< 0.01
Molybdenum	ug/L	1.1	0.66	< 0.50	3.3	3.4	0.54	1.3	0.55	0.71
Nickel	ug/L	1.6	1	1.3	4.1	3.6	< 1.0	< 1.0	2.4	< 1.0
Potassium	ug/L	1300	960	900	10000	9700	1200	1500	1200	1200
Selenium	ug/L	< 2.0	< 2.0	< 2.0	< 2.0	< 2.0	< 2.0	< 2.0	< 2.0	< 2.0
Silicon	ug/L	1100	760	1100	2300	2200	1100	1500	3100	1100
Silver	ug/L	< 0.10	< 0.10	< 0.10	< 0.10	< 0.10	< 0.10	< 0.10	< 0.10	< 0.10
Sodium	ug/L	420000	220000	77000	140000	130000	35000	31000	27000	9900
Strontium	ug/L	390	230	120	290	280	300	770	670	86
Tellurium	ug/L	< 1.0	< 1.0	< 1.0	< 1.0	< 1.0	< 1.0	< 1.0	< 1.0	< 1.0
Thallium	ug/L	< 0.050	< 0.050	< 0.050	< 0.050	< 0.050	< 0.050	< 0.050	< 0.050	< 0.050
Tin	ug/L	< 1.0	< 1.0	< 1.0	6.1	6.1	< 1.0	< 1.0	< 1.0	< 1.0
Titanium	ug/L	6.3	5.4	16	16	16	18	7.9	44	23
Tungsten	ug/L	< 1.0	< 1.0	< 1.0	< 1.0	< 1.0	< 1.0	< 1.0	< 1.0	< 1.0
Uranium	ug/L	0.16	0.24	< 0.10	0.21	0.22	< 0.10	0.32	0.17	0.13
Vanadium	ug/L	2.4	0.91	2.1	8.3	8.2	3.8	1.3	3.6	2.2
Zinc	ug/L	39	41	40	73	71	160	80	130	91
Zirconium	ug/L	< 1.0	< 1.0	< 1.0	< 1.0	< 1.0	< 1.0	< 1.0	< 1.0	< 1.0
Petroleum Hydrocarbons (and BTEX)										
Benzene	ug/L	< 0.20	< 0.20	< 0.20	< 0.20	< 0.20	< 0.20	< 0.20	< 0.20	< 0.20
Toluene	ug/L	0.31	< 0.20	< 0.20	< 0.20	< 0.20	< 0.20	< 0.20	< 0.20	< 0.20
Ethylbenzene	ug/L	< 0.20	< 0.20	< 0.20	< 0.20	< 0.20	< 0.20	< 0.20	< 0.20	< 0.20
o-Xylene	ug/L	< 0.20	< 0.20	< 0.20	< 0.20	< 0.20	< 0.20	< 0.20	0.38	< 0.20
m,p-Xylenes	ug/L	< 0.40	< 0.40	< 0.40	< 0.40	< 0.40	< 0.40	< 0.40	0.46	< 0.40
Xylenes, Total	ug/L	< 0.40	< 0.40	< 0.40	< 0.40	< 0.40	< 0.40	< 0.40	0.84	< 0.40
Petroleum Hydrocarbons - F1 (C6-C10)-BTEX	ug/L	< 25	< 25	< 25	< 25	< 25	< 25	< 25	< 25	< 25
Petroleum Hydrocarbons - F1 (C6-C10)	ug/L	< 25	< 25	< 25	< 25	< 25	< 25	< 25	< 25	< 25
Petroleum Hydrocarbons - F2 (C10-C16)	ug/L	< 100	< 100	< 100	< 100	< 100	< 100	< 100	< 100	< 100
Petroleum Hydrocarbons - F3 (C16-C34)	ug/L	< 200	< 200	< 200	< 200	< 200	< 200	< 200	< 200	< 200
Petroleum Hydrocarbons - F4 (C34-C50)	ug/L	< 200	< 200	< 200	< 200	< 200	< 200	< 200	< 200	< 200
Reached Baseline at C50	ug/L	YES	YES	YES	YES	YES	YES	YES	YES	YES
Radiological										
Carbon-14	Bq/L	< 20	< 20	< 20	< 20	< 20	< 20	< 20	< 20	< 20
Cesium-134	Bq/L	< 1	< 1	< 1	< 1	< 1	< 1	< 1	< 1	< 1
Cesium-137	Bq/L	< 1	< 1	< 1	< 1	< 1	< 1	< 1	< 1	< 1
Cobalt-60	Bq/L	-	< 1	< 1	< 1	< 1	-	< 1	< 1	< 1
Tritium (HTO)	Bq/L	974	145	50	78	79	182	1400	1110	1370

Table F.6: Stormwater Data - Lake Water East

		Concentration							
		Catchment 10				Catchment 13			
Station ID		M2-1				M5-1			
Unit		20-Aug-15	28-Oct-15	19-Nov-15	11-Jun-16	20-Aug-15	28-Oct-15	19-Nov-15	11-Jun-16
General									
Chloride	mg/L	600	110	890	180	320	16	340	92
Conductivity	mS/cm	2.2	0.539	3.38	0.814	1.36	0.135	1.59	0.455
Hardness, Calcium Carbonate	mg/L	150	81	330	76	130	41	190	63
pH	pH units	7.85	7.68	7.8	7.98	7.82	6.76	7.87	7.95
Phosphorous	mg/L	0.096	0.065	0.038	0.11	0.092	0.061	0.032	0.12
Total Suspended Solids	mg/L	72	46	20	110	< 10	25	< 10	82
Toxicity									
% Mortality of Daphnia Magna in 100% Effluent Treatment	%	0	0	0	0	0	0	0	0
% Mortality of Rainbow Trout in 100% Effluent Treatment	%	0	0	0	0	0	0	0	0
Metals									
Aluminum	ug/L	1800	990	740	1500	170	970	53	1600
Antimony	ug/L	0.84	1.4	0.64	0.61	0.51	0.62	< 0.50	0.88
Arsenic	ug/L	< 1.0	< 1.0	< 1.0	< 1.0	< 1.0	< 1.0	< 1.0	< 1.0
Barium	ug/L	50	20	73	35	29	9.3	32	41
Beryllium	ug/L	< 0.50	< 0.50	< 0.50	< 0.50	< 0.50	< 0.50	< 0.50	< 0.50
Bismuth	ug/L	< 1.0	< 1.0	< 1.0	< 1.0	< 1.0	< 1.0	< 1.0	< 1.0
Boron	ug/L	48	11	35	< 10	41	< 10	43	13
Cadmium	ug/L	< 0.10	< 0.10	< 0.10	< 0.10	< 0.10	< 0.10	< 0.10	< 0.10
Calcium	ug/L	65000	34000	100000	66000	41000	16000	54000	47000
Chromium	ug/L	< 5.0	< 5.0	< 5.0	8.7	< 5.0	< 5.0	< 5.0	5.2
Cobalt	ug/L	1	< 0.50	0.57	1.2	< 0.50	< 0.50	< 0.50	1.1
Copper	ug/L	18	4.3	3.9	8	7.6	3.2	2.4	6.2
Iron	ug/L	1800	1200	760	3100	310	720	< 100	1900
Lead	ug/L	3.8	2.8	1.1	6.2	0.55	1.6	< 0.50	4
Lithium	ug/L	5.6	< 5.0	5.2	< 5.0	< 5.0	< 5.0	< 5.0	5.1
Magnesium	ug/L	7200	3100	16000	4500	6100	1300	9400	3500
Manganese	ug/L	170	56	220	200	66	30	27	81
Mercury (filtered)	ug/L	< 0.01	< 0.01	< 0.01	< 0.01	< 0.01	< 0.01	< 0.01	< 0.01
Molybdenum	ug/L	1.8	0.56	1.9	0.8	1.2	< 0.50	1.8	0.58
Nickel	ug/L	3	1.8	1.5	4.2	1.4	1.6	< 1.0	3
Potassium	ug/L	3200	1700	3400	2300	2500	1100	2200	2400
Selenium	ug/L	< 2.0	< 2.0	< 2.0	< 2.0	< 2.0	< 2.0	< 2.0	< 2.0
Silicon	ug/L	5000	2300	3800	4400	1100	2000	930	7600
Silver	ug/L	< 0.10	< 0.10	< 0.10	< 0.10	< 0.10	< 0.10	< 0.10	< 0.10
Sodium	ug/L	400000	71000	540000	130000	220000	11000	250000	59000
Strontium	ug/L	400	160	680	230	660	110	1000	360
Tellurium	ug/L	< 1.0	< 1.0	< 1.0	< 1.0	< 1.0	< 1.0	< 1.0	< 1.0
Thallium	ug/L	< 0.050	< 0.050	< 0.050	< 0.050	< 0.050	< 0.050	< 0.050	< 0.050
Tin	ug/L	< 1.0	< 1.0	< 1.0	< 1.0	< 1.0	< 1.0	< 1.0	< 1.0
Titanium	ug/L	66	38	13	53	6.2	26	< 5.0	43
Tungsten	ug/L	< 1.0	< 1.0	< 1.0	< 1.0	< 1.0	< 1.0	< 1.0	< 1.0
Uranium	ug/L	0.3	0.19	0.78	0.27	0.17	< 0.10	0.64	0.6
Vanadium	ug/L	5.1	2.6	1.7	5	1	1.6	< 0.50	4.8
Zinc	ug/L	100	91	99	190	69	38	61	72
Zirconium	ug/L	1.2	< 1.0	< 1.0	1.1	< 1.0	< 1.0	< 1.0	2.7
Petroleum Hydrocarbons (and BTEX)									
Benzene	ug/L	< 0.20	< 0.20	< 0.20	< 0.20	< 0.20	< 0.20	< 0.20	< 0.20
Toluene	ug/L	0.44	< 0.20	< 0.20	< 0.20	0.44	< 0.20	< 0.20	< 0.20
Ethylbenzene	ug/L	< 0.20	< 0.20	< 0.20	< 0.20	< 0.20	< 0.20	< 0.20	< 0.20
o-Xylene	ug/L	< 0.20	< 0.20	< 0.20	< 0.20	< 0.20	< 0.20	< 0.20	< 0.20
m,p-Xylenes	ug/L	< 0.40	< 0.40	< 0.40	< 0.40	< 0.40	< 0.40	< 0.40	< 0.40
Xylenes, Total	ug/L	< 0.40	< 0.40	< 0.40	< 0.40	< 0.40	< 0.40	< 0.40	< 0.40
Petroleum Hydrocarbons - F1 (C6-C10)-BTEX	ug/L	< 25	< 25	< 25	< 25	< 25	< 25	< 25	< 25
Petroleum Hydrocarbons - F1 (C6-C10)	ug/L	< 25	< 25	< 25	< 25	< 25	< 25	< 25	< 25
Petroleum Hydrocarbons - F2 (C10-C16)	ug/L	< 100	< 100	< 100	< 100	< 100	< 100	< 100	< 100
Petroleum Hydrocarbons - F3 (C16-C34)	ug/L	< 200	< 200	< 200	< 200	< 200	< 200	< 200	< 200
Petroleum Hydrocarbons - F4 (C34-C50)	ug/L	< 200	< 200	< 200	< 200	< 200	< 200	< 200	< 200
Reached Baseline at C50	ug/L	YES	YES	YES	YES	YES	YES	YES	YES
Radiological									
Carbon-14	Bq/L	< 20	< 20	< 20	< 20	< 20	< 20	< 20	< 20
Cesium-134	Bq/L	< 1	< 1	< 1	< 1	< 1	< 1	< 1	< 1
Cesium-137	Bq/L	< 1	< 1	< 1	< 1	< 1	< 1	< 1	< 1
Cobalt-60	Bq/L	-	< 1	< 1	< 1	-	< 1	< 1	< 1
Tritium (Hydrogen-3)	Bq/L	227	41	222	53	158	< 15	111	< 15

Table F.7: Stormwater Data - Lake Water West

		Concentration					
		Catchment 3					
Station ID		MH211					
Unit	20-Aug-15	28-Oct-15	19-Nov-15	20-Aug-15	11-Jun-16	Dup of MH211	
General							
Chloride	mg/L	22	2.1	36	22	2.6	2.4
Conductivity	mS/cm	0.225	0.073	0.314	0.225	0.063	0.064
Hardness, Calcium Carbonate	mg/L	62	32	89	63	23	23
pH	pH units	7.6	7.66	7.92	7.55	7.49	7.56
Phosphorous	mg/L	0.16	0.06	0.083	0.16	0.11	0.11
Total Suspended Solids	mg/L	40	11	< 10	34	<10	<10
Toxicity							
% Mortality of Daphnia Magna in 100% Effluent Treatment	%	0	0	0	0	0	-
% Mortality of Rainbow Trout in 100% Effluent Treatment	%	0	0	0	0	30	-
Metals							
Aluminum	ug/L	550	160	130	570	120	100
Antimony	ug/L	3.7	0.9	1.5	3.6	0.76	0.94
Arsenic	ug/L	< 1.0	< 1.0	< 1.0	< 1.0	<1.0	<1.0
Barium	ug/L	24	8.4	26	23	4.8	4.2
Beryllium	ug/L	< 0.50	< 0.50	< 0.50	< 0.50	<0.50	<0.50
Bismuth	ug/L	< 1.0	< 1.0	< 1.0	< 1.0	<1.0	<1.0
Boron	ug/L	29	< 10	14	28	<10	<10
Cadmium	ug/L	0.69	0.23	0.15	0.87	0.21	0.2
Calcium	ug/L	27000	11000	32000	27000	8500	8600
Chromium	ug/L	< 5.0	< 5.0	< 5.0	< 5.0	<5.0	<5.0
Cobalt	ug/L	0.73	< 0.50	< 0.50	0.72	<0.50	<0.50
Copper	ug/L	43	12	11	42	7.6	6.9
Iron	ug/L	790	280	220	800	160	120
Lead	ug/L	4.9	2.2	1.1	5.1	1.3	1.3
Lithium	ug/L	< 5.0	< 5.0	< 5.0	< 5.0	<5.0	<5.0
Magnesium	ug/L	2200	690	2100	2300	520	480
Manganese	ug/L	42	15	20	41	11	11
Mercury (filtered)	ug/L	< 0.01	< 0.01	0.01	< 0.01	<0.01	<0.01
Molybdenum	ug/L	0.99	< 0.50	0.85	1	<0.50	<0.50
Nickel	ug/L	2.9	< 1.0	1	2.7	<1.0	<1.0
Potassium	ug/L	2200	750	1800	2200	1100	1100
Selenium	ug/L	< 2.0	< 2.0	< 2.0	< 2.0	<2.0	<2.0
Silicon	ug/L	2100	590	2000	2000	470	450
Silver	ug/L	< 0.10	< 0.10	< 0.10	0.17	<0.10	<0.10
Sodium	ug/L	20000	2000	29000	20000	2200	2200
Strontium	ug/L	110	30	120	110	24	24
Tellurium	ug/L	< 1.0	< 1.0	< 1.0	< 1.0	<1.0	<1.0
Thallium	ug/L	< 0.050	< 0.050	< 0.050	< 0.050	<0.050	<0.050
Tin	ug/L	< 1.0	< 1.0	< 1.0	< 1.0	<1.0	<1.0
Titanium	ug/L	18	6.8	5	17	6.5	<5.0
Tungsten	ug/L	< 1.0	< 1.0	< 1.0	< 1.0	<1.0	<1.0
Uranium	ug/L	0.13	< 0.10	0.34	0.14	0.1	<0.10
Vanadium	ug/L	2.8	1	1.2	2.9	0.88	0.71
Zinc	ug/L	510	220	150	510	160	160
Zirconium	ug/L	< 1.0	< 1.0	< 1.0	< 1.0	<1.0	<1.0
Petroleum Hydrocarbons (and BTEX)							
Benzene	ug/L	< 0.20	< 0.20	< 0.20	< 0.20	<0.20	<0.20
Toluene	ug/L	0.22	< 0.20	< 0.20	0.21	<0.20	<0.20
Ethylbenzene	ug/L	< 0.20	< 0.20	< 0.20	< 0.20	0.49	0.41
o-Xylene	ug/L	0.36	< 0.20	< 0.20	0.38	0.7	0.66
m,p-Xylenes	ug/L	0.56	< 0.40	< 0.40	0.55	1.5	1.6
Xylenes, Total	ug/L	0.92	< 0.40	< 0.40	0.94	2.2	2.3
Petroleum Hydrocarbons - F1 (C6-C10)-BTEX	ug/L	< 25	< 25	< 25	< 25	<25	<25
Petroleum Hydrocarbons - F1 (C6-C10)	ug/L	< 25	< 25	< 25	< 25	<25	<25
Petroleum Hydrocarbons - F2 (C10-C16)	ug/L	< 100	< 100	< 100	< 100	<100	<100
Petroleum Hydrocarbons - F3 (C16-C34)	ug/L	210	< 200	< 200	230	<200	<200
Petroleum Hydrocarbons - F4 (C34-C50)	ug/L	< 200	< 200	< 200	< 200	<200	<200
Reached Baseline at C50	ug/L	YES	YES	YES	YES	YES	YES
Radiological							
Carbon-14	Bq/L	< 20	< 20	< 20	< 20	<20	<20
Cesium-134	Bq/L	< 1	< 1	< 1	< 1	<1	<1
Cesium-137	Bq/L	< 1	< 1	< 1	< 1	<1	<1
Cobalt-60	Bq/L	-	< 1	< 1	-	<1	<1
Tritium (HTO)	Bq/L	3520	7080	39600	3480	2930	2930

Table F.9: Pickering Site Soil Data

Table with multiple columns: Parameter, Unit, Detection Limit, and 28 sampling locations (GMS-26 to SS6B, SS6A, SS6B, SS6A, SS6B, SS6A, SS6B, SS6A, SS6B, SS6A, SS6B, SS6A, SS6B, SS6A, SS6B, SS6A, SS6B, SS6A, SS6B, SS6A, SS6B, SS6A, SS6B, SS6A, SS6B, SS6A, SS6B, SS6A, SS6B). Rows include Inorganics (Conductivity, Cyanide, etc.), Metals (Antimony, Arsenic, etc.), Petroleum Hydrocarbons (Benzene, Ethylbenzene, etc.), VOCs (1,1,2,2-Tetrachloroethane, etc.), Semi-VOCs (1,8-Dimethylnaphthalene, etc.), and Radionuclides (Carbon-14, Cobalt-60, etc.).

Appendix G Stormwater Runoff Calculations

G.1 Introduction

This appendix summarizes the approach used to model runoff flows reporting to two discharge locations at the PN site. The two discharge locations are M2-1 and M5-1, shown on the Figure G.1. These two catchments have been changed and therefore an assessment was considered necessary to assess flow resulting from rainfall. Other catchments in the area have not been altered since previous sampling. The calculations are used to assess the run-off into M5-1.

Modelling was undertaken using the Environmental Protection Agency Storm Water Management Model 5.0 (SWMM5) hydrologic model, and verified for the M2-1 discharge location based on continuous flow measurements at M2-1 during three storm events in 2015 and one event in 2016.

G.2 Methodology

G.2.1 Catchment Delineation

Mapping information from the catchments contributing to the two discharge locations (M2-1 and M5-1) was used. Drawings show general drainage directions and culverts under internal roadways but do not show details of the storm sewer system in the catchments.

The drainage catchments contributing to M2-1 and M5-1 are shown on Figure G.1, with M2-1 showing a contributing area of 2 ha and M5-1 showing a contributing area of 4.5 ha.

G.2.2 Modelling Layout

Both M2-1 and M5-1 catchments were modelled in SWMM5 as single catchment. In this method, the modeled catchment was described as a single unit draining to a single outlet, rather than multiple catchments, catch basins, culverts, and pipes. This is considered acceptable for this level of estimation, as the catchments are both less than 5 ha and the stormwater management systems in each catchment are not expected to have a significant impact on losses. Neither of the two catchments appears to have significant runoff storage features (i.e. no stormwater ponds), and therefore only minimal storage effects on the peak flows are expected. Both catchments were assumed to have a surface slope of 1% consistent with parking lot grading.

Based on mapping, knowledge of the area, Google Earth imagery and typical literature values assumptions were made related to the surface conditions. The catchment M2-1 was assumed to be 25% impervious and 75% pervious (assuming gravel parking areas), while the catchment for M5-1 was assumed to be 100% impervious which is considered a conservative assumption (i.e. results in the maximum amount of flow). Surface depression

storage in both catchments was assumed as 2 mm for impervious surfaces (reflecting paved parking surfaces) and 5 mm for pervious surfaces (reflecting landscaped areas).

G.2.3 Rainfall Data

Site rainfall was measured at an on-site rain gauge installed for the stormwater sampling program. Rainfall data at the site was provided on a 5-min time step for the following time periods:

- Event 1: August 19, 2015 0:00 to August 23, 2015 0:00;
- Event 2: October 28, 2015 0:00 to November 1, 2015 0:00;
- Event 3: November 18, 2015 12:00 to November 21, 2015 12:00; and
- Event 4: June 10, 2016 7:00 to June 14, 2016 23:55.

G.2.4 Verification Data

A flow monitoring station installed at the M2-1 discharge point was used to record the three runoff events in 2015 and one in 2016 (listed above). The total flow at the station for each of the four events is shown in Table G.1 below. Site rainfall records were compared to the flow records to estimate the amount of rainfall which contributed to the observed runoff; generally this was assumed to be any rainfall within 3 hours prior to the start of runoff and the last recorded runoff at the monitoring station. The resulting rainfall volumes contributing to runoff are also shown in Table G.1 below.

Table G.1: M2-1 Measured Discharge Volumes

Event Number:	Rainfall Depth (mm)	Measured Flow at M2-1 (m³)
Event 1 (Aug 2015)	5.0 (7mm over 24h)*	19.9
Event 2 (Oct 2015)	54.4	795
Event 3 (Nov 2015)	5.0 (5.8mm over 24h)*	7.76
Event 4 (June 2016)	25.4	201

* – the smaller rainfall depths were those that were considered to contribute to flow (i.e. rainfall before or after those events contributed to no or marginal flow).

The EPA SWMM5 model uses Soil Conservation Service (SCS) Curve Number method to estimate infiltration. This method uses an assumed curve number for soil (based on literature values) and associated empirically derived runoff responses to convert rainfall over the previous portion of a subcatchment area into runoff (in the impervious portion of

the subcatchment, all rainfall becomes runoff). The method is further described in USDA “Urban Hydrology for Small Watersheds” (TR-55, 1986).

Verification of the model at M2-1 was completed by varying the curve number for the pervious area in the model (and thus the pervious area infiltration) until the model runoff approximately matched the measured runoff for the four measured storm events. A curve number was not required for M5-1 since this catchment is conservatively assumed to be 100% impervious, therefore a similar adjustment for M5-1 was not required.

G.3 Results and Discussion

The M2-1 catchment model was run for a range of curve numbers in order to estimate a best-fit to the measured data (based on difference in runoff volumes); ultimately a curve number of 89 was found to produce the best approximation. Based on the Design Chart 1.09 of the MTO Drainage Management Manual (2003), this value is equivalent to a farmstead over clay soils. The flow results using a curve number of 89 for the pervious area infiltration in the model are shown in Table G.2 below.

Table G.2: M2-1 Measured and Modeled Runoff

Event	Measured Flow at M2-1 (m ³)	Modeled Flow at M2-1 (m ³)	Difference (m ³)	Difference (%)
Event 1 (Aug 2015)	19.9	25.5	+5.6	+28%
Event 2 (Oct 2015)	795	739	-56.2	-7%
Event 3 (Nov 2015)	7.76	18.7	+10.9	+141%
Event 4 (Jun 2016)	201	196	-4.4	-2%

Generally, Event 2 and 4 possess the closest results presenting a modeled flow versus measured flow difference of less than 10%, while the modeled results of Events 1 and 3 are 28% and 141% greater than the logger recorded results for August and November, respectively. This is assumed to be the result of the small size of the storm events (both August and November storms were approximately 5 mm while the August and June events were 54.4 and 25.4 mm respectively), the result of which is that small changes in total event flow may have an exaggerated impact on the percent change. In addition the Event 3 consisted of an intermittent storm with low rainfall resulting in some flow in two discrete periods within the 24hours and likely resulting in less predictable modelling.

The model results for M5-1 for the four storm events and a comparison of runoff volume versus depth of rainfall are shown in Table G.3 below. These values tend to be very sensitive to rainfall intensity since shorter, more intense rainfall generates more runoff than

a less intense rainfall of equal volume, as well as surface storage since ponded water in a SWMM5 subcatchment must first exceed the surface storage depth before runoff occurs, which typically prevents runoff of the first 2-5 mm of rainfall.

Table G.3: M5-1 Model Results

Event	M5-1	
	Modeled Runoff Vol. (cu. m)	Vol./Depth of Rainfall (m ³ /mm)
Event 1 (Aug 2015)	338	67.5
Event 2 (Oct 2015)	3,700	68.0
Event 3 (Nov 2015)	246	49.2
Event 4 (Jun 2016)	1,640	64.7

Three of the events have similar volume/depth of rainfall ratios and the one variation (Event 3) was considered a small and non-representative storm.

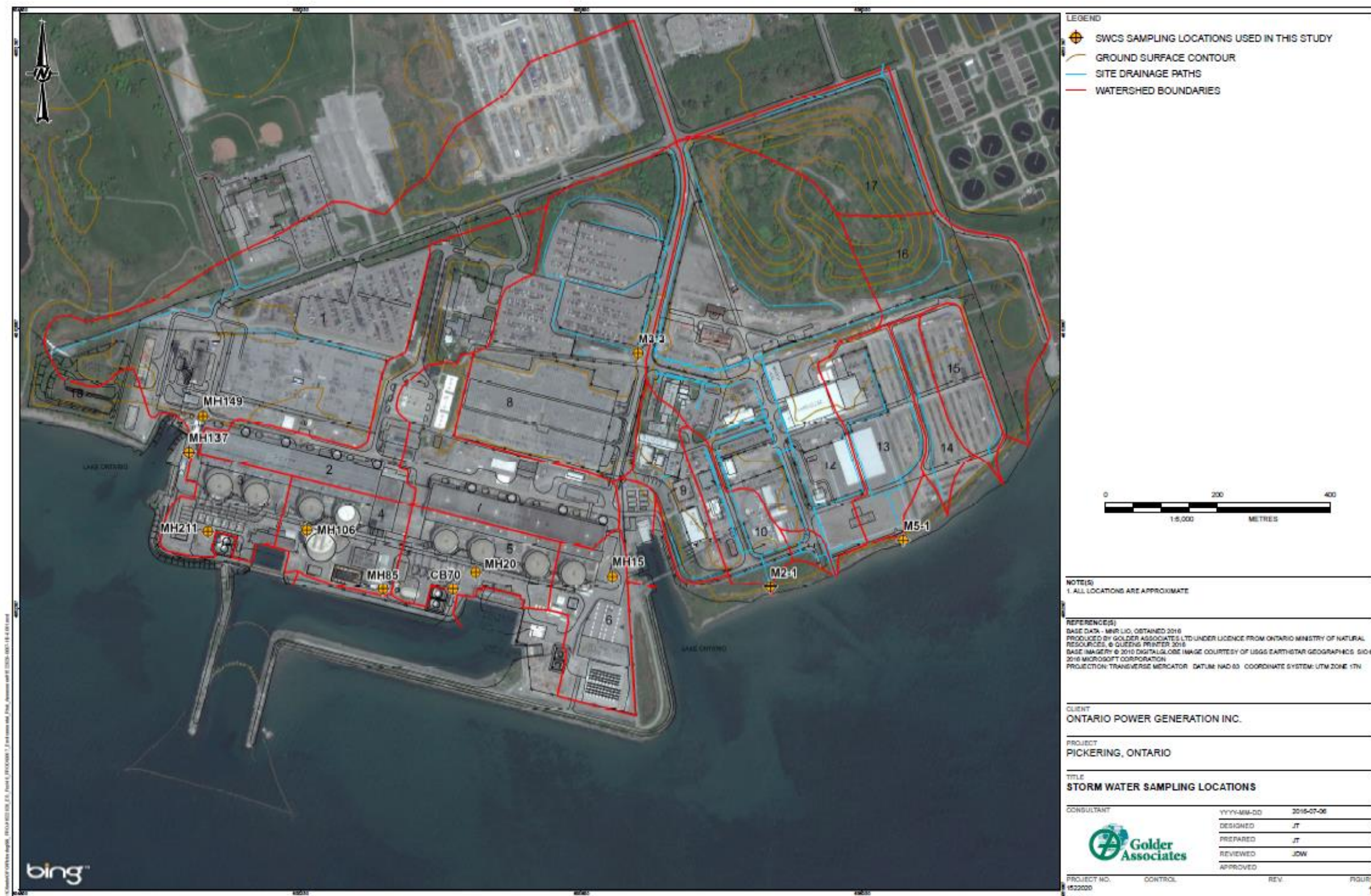

Figure G.1: Stormwater Sampling Locations